

CITY OF HEATH, OHIO



CITY ADMINISTRATION BUILDING

POLICE DEPARTMENT
DIVISION OF BUILDING & ZONING
TAX DEPARTMENT

1287 HEBRON ROAD
HEATH, OH 43056
(740) 522-1420

WATER TREATMENT PLANT
70 DORSEY MILL RD. EAST
HEATH, OH 43056
(740) 522-1677

SEWAGE TREATMENT PLANT
719 LICKING VIEW DR.
HEATH, OH 43056
(740) 522-4802

STREET DEPARTMENT
550 DOG LEG ROAD
HEATH, OH 43056
(740) 522-4858

PARKS & RECREATION
580 CYNTHIA STREET
HEATH, OH 43056
(740) 522-3361

ENGINEERS:



1555 WEST MAIN STREET
NEWARK, OH 43055
TEL. 740.344.5451
FAX 614.360.0023

WATER DISTRIBUTION
60 DORSEY MILL RD. EAST
HEATH, OH 43056
(740) 522-6282

FIRE DEPARTMENT
FIRE STATION #1
193 HEATH ROAD
HEATH, OH 43056
(740) 522-4585

CONSTRUCTION & MATERIALS SPECIFICATIONS

2023 UPDATES

<http://www.heathohio.gov>

GENERAL			ROADWAY & DRAINAGE (CONTINUED)			SANITARY SEWER (CONTINUED)		
DWG#	DRAWING TITLE	REVISED	DWG#	DRAWING TITLE	REVISED	DWG#	DRAWING TITLE	REVISED
GEN-0	GENERAL SPECIFICATIONS AND NOTES	MAR-22	RD-7	TYPICAL SECTION: PAVEMENT WIDENING	MAY-97	SA-7	SERVICE LATERAL	MAY-97
	G00 - SPECIFICATIONS	OCT-05	RD-8	CUL-DE-SAC & TEMPORARY TURNAROUND DETAIL	MAR-22	SA-8	FORCE MAIN AIR RELEASE VALVE	MAY-97
	G01 - UTILITY OWNERS	OCT-05	RD-9	omitted	OCT-05	SA-9	omitted	OCT-05
	G02 - UTILITY LOCATIONS	OCT-05	RD-10	COMBINED CURB AND GUTTER	MAR-22	SA-10	STANDARD MANHOLE COVER (PUBLIC SANITARY SEWER)	MAR-05
	G03 - SURVEYS	OCT-05	RD-11	omitted	OCT-05	SA-11	SANITARY PUMP STATION	MAR-22
	G04 - MODIFICATIONS	OCT-05	RD-12	omitted	OCT-05	SA-12	EFFLUENT SAMPLING STATION	JAN-21
	G05 - SAFETY	OCT-05	RD-13	RESIDENTIAL DRIVEWAY	MAR-22	WATER WORK		
	G06 - REVIEW OF PROJECT SITE	OCT-05	RD-14	COMMERCIAL DRIVEWAY	MAR-22			
	G07 - IRON PINS AND MONUMENTS	OCT-05	RD-15	STANDARD SIDEWALK	MAR-22	DWG#	DRAWING TITLE	REVISED
	G08 - NOTIFICATION OF CONSTRUCTION	OCT-05	RD-16	omitted	OCT-05	WA-0	WATER SPECIFICATIONS & NOTES	MAR-22
	G09 - CONSTRUCTION STAKING	OCT-05	RD-17	omitted	MAR-22		W00- WATER WORK	MAR-22
	G10 - SANITARY FACILITIES	OCT-05	RD-18	omitted	OCT-05		W01- WATER LINE DEPTH	MAY-17
	G11 - LEGAL DIMENSIONS AND WEIGHT LIMITS	OCT-05	ST-1	STANDARD PRECAST STORM MANHOLE FOR 8"-24" DIA. PIPE	OCT-17		W02- BACKFILL	MAY-17
	G12 - CONTINGENCY QUANTITIES	OCT-05	ST-2	STANDARD PRECAST STORM MANHOLE FOR 30"-42" DIA. PIPE	OCT-17		W03- FIRE HYDRANTS	JAN-21
	G13 - USE OF FIRE HYDRANTS	OCT-05	ST-3	CURB AND GUTTER INLET	MAY-97		W04- WATER MAIN PROTECTION	MAY-17
	G14 - EMERGENCY PHONE NUMBER	OCT-05	ST-4	omitted	OCT-05		W05- CUSTOMER NOTIFICATION	MAY-17
	G15 - INCLUSIVE BID	OCT-05	ST-5	ORIFICE DETAIL	MAY-97		W06- WATERLINE CONNECTIONS	MAY-17
	G16 - WORKING HOURS	NOV-22	ST-6	ENDWALL	MAY-97		W07- WATERLINE PROFILE	MAY-17
	G17 - ESTIMATED QUANTITIES	OCT-05	ST-7	HEADWALL	MAY-97		W08- WATER MAIN AND SERVICE LOCATION	MAY-17
	G18 - RECORD DRAWINGS	MAR-22	ST-8	STANDARD MANHOLE COVER (PUBLIC STORM SEWER)	MAR-05		W09- CONSTRUCTION PROCEDURE	MAY-17
	ITEM SPECIAL - RECORD CONSTRUCTION DRAWINGS	MAR-22	SANITARY SEWER				W10- SERVICE DURING RELOCATION	MAY-17
	G19 - SHOP DRAWINGS AND/ OR PRODUCT DATA	OCT-05	DWG#	DRAWING TITLE	REVISED		W11- WATERLINE TESTING AND DISINFECTION	MAY-17
	G20 - NON-RUBBER TIRE VEHICLES	OCT-05	SA-0	SANITARY SPECIFICATIONS AND NOTES	MAR-22		W12- CROSSINGS AND CONNECTIONS TO EXISTING PIPES AND UTILITIES	MAY-17
	G22 - PROTECTION AND RESTORATION OF PROPERTY	OCT-05		S00 - SANITARY SEWER	FEB-15		W13- INSTALLATION AND CONFLICTS	MAY-17
	G23 - WORK LIMITS	OCT-05		S01- BACKFILL	OCT-05		W14- VALVE EXTENSION	MAY-17
	G24 - PRECONSTRUCTION CONFERENCE	OCT-05		S02- SERVICE CONNECTIONS	OCT-05		W15- SERVICE CONNECTIONS	MAY-17
	G25 - NOT USED	OCT-05		S03- MANHOLE LOCATIONS	OCT-05		W16- INDIVIDUAL BOOSTER PUMPS	MAY-17
	G27 - FINAL CLEAN-UP	OCT-05		S04- CONNECTION TO EXISTING PIPE	OCT-05		W17- MINIMUM PRESSURE	MAY-17
	G28 - NOT USED	OCT-05		S05- CONNECTIONS TO EXISTING MANHOLES	OCT-05	WA-1	CONCRETE VALVE SUPPORTS	MAY-97
	G29 - PERFORMANCE BOND	MAR-22		S06- CONNECTIONS TO SANITARY SEWER SYSTEM	OCT-05	WA-2	BACKING FOR BENDS AND TEES	MAY-97
	G30 - INDEMNIFICATION	OCT-05		S07- PROFILE	OCT-05	WA-3	GATE VALVE WITH BOX	OCT-17
	G31 - PAVING OVER VALVES AND MANHOLES	JAN-21		S08- TOP OF CASTING ELEVATIONS	OCT-05	WA-4	BUTTERFLY VALVE WITH BOX	FEB-12
	G32 - PAVEMENT CLEANING	OCT-05		S09- PLUGS	OCT-05	WA-5	STUB AND PLUG ASSEMBLY	FEB-12
	G33 - DUST CONTROL	OCT-05		S10- SEQUENCE OF OPERATIONS	OCT-05	WA-6	FIRE HYDRANT ASSEMBLY, TYPE 1	MAR-22
	G34 - CONSTRUCTION NOISE	OCT-05		S11- EXISTING SEWERS AND STRUCTURES	OCT-05	WA-7	FIRE HYDRANT ASSEMBLY, TYPE 2	FEB-15
	ITEM 624 - MOBILIZATION, AS PER PLAN	OCT-05		S12- EXISTING SEWAGE FLOWS	OCT-05	WA-8	BLOW-OFF- ASSEMBLY	MAY-97
	G35 - NOT USED	OCT-05		S13- SANITARY SEWER-MANHOLE CONNECTIONS	OCT-05	WA-9	FIRELINE METER PIT	FEB-12
	G36 - PROTECTION OF WORK SITE	OCT-05		S14- SEWER-WATER MAIN CROSSING	OCT-05	WA-10	RESIDENTIAL METER SETTINGS	FEB-15
	G37 - US MAIL DELIVERY	OCT-05		S15- UNRECORDED SANITARY CONNECTIONS	OCT-05	WA-11	WATERLINE LOWERING	MAY-97
	G38 - WEATHER CONDITIONS	DEC-05		S16- Y-POLE INSTALLATION	OCT-05	WA-12	CASING PIPE	MAY-97
	G39 - CONCRETE COLLARS	OCT-17		S17- SANITARY SEWER LATERALS	OCT-05	WA-13	LOCATING TAPE AND WIRE	FEB-15
ROADWAY & DRAINAGE				S18- SANITARY TESTING	OCT-05	WA-14	TRACE WIRE PLAN (WATER)	FEB-15
DWG#	DRAWING TITLE	REVISED		S19- SANITARY MANHOLE	MAR-22	DESIGNER NOTE: THE DESIGN ENGINEER AND TRC SHALL DETERMINE APPLICABLE STANDARD NOTES NECESSARY FOR A PROJECT. THERE MAY BE INSTANCES WHERE THE STANDARD NOTE WILL NEED MODIFIED. WHEN A STANDARD NOTE IS MODIFIED FOR A SPECIFIC PROJECT, THE DESIGN ENGINEER SHALL ADD AN ASTERISK (*) PRIOR TO THE NOTE IDENTIFIER. EXAMPLE AS FOLLOWS: *G04 - MODIFICATIONS ANY MODIFICATIONS OR CHANGES TO THE WORK, AS SHOWN ON THE DRAWINGS, MUST HAVE PRIOR WRITTEN APPROVAL BY THE CITY ENGINEER, CITY OF HEATH.		
RD-0	ROADWAY AND DRAINAGE SPECIFICATIONS & NOTES	JAN-21		S20- CONCRETE COLLAR	OCT-17			
RD-1	TYPICAL SECTIONS	MAR-22	SA-1	STANDARD PRECAST SANITARY MANHOLE FOR 8"-24" DIA. PIPE	OCT-17			
RD-2	omitted	OCT-05	SA-2	STANDARD PRECAST SANITARY MANHOLE FOR 30"-42" DIA. PIPE	OCT-17			
RD-3	PAVEMENT UTILITY TRENCH DETAIL AND PAVEMENT RESORATION	MAR-22	SA-3	MANHOLE STEP	MAY-97			
RD-4	TYPICAL TRENCH DETAIL AND PAVEMENT RESTORATION	MAR-22	SA-4	MANHOLE INVERT	MAY-97			
RD-5	omitted	OCT-05	SA-5	OUTSIDE DROP FOR MANHOLE	MAY-97			
RD-6	omitted	OCT-05	SA-6	INSIDE DROP FOR EXISTING MANHOLES	MAY-97			

DATE
11-2005
12/9/05
02-2012
02-2015
05-2017
10-2017
01-2021
11-2022

INDEX

NUMBER
INDEX

SDATES - \$TIMES - \$USERNAMES - \$FILES

G00 - SPECIFICATIONS

THE CURRENT REQUIREMENTS OF THE CITY OF HEATH, THE CONSTRUCTION AND MATERIALS SPECIFICATIONS OF THE OHIO DEPARTMENT OF TRANSPORTATION, INCLUDING ALL SUPPLEMENTS THERETO, AS WELL AS THE MANUFACTURERS RECOMMENDATIONS FOR INSTALLATION SHALL GOVERN THE MATERIALS AND WORKMANSHIP TO COMPLETE THE IMPROVEMENTS SET FORTH IN THESE PLANS.

G01 - UTILITY OWNERS

THE FOLLOWING UTILITIES AND OWNERS ARE LOCATED WITHIN THE WORK LIMITS OF THE PROJECT:

WATER:
CITY OF HEATH
WATER DISTRIBUTION
60 DORSEY MILL RD. EAST
HEATH, OH 43056
(740) 522-6282

SANITARY SEWER:
CITY OF HEATH
SEWAGE TREATMENT PLANT
719 LICKING VIEW DR.
HEATH, OH 43056
(740) 522-4802

WATER:
CITY OF HEATH
WATER TREATMENT
70 DORSEY MILL RD. EAST
HEATH, OH 43056
(740) 522-1677

STORM
CITY OF HEATH
STREET DEPARTMENT
550 DOG LEG ROAD
HEATH, OH 43056
(740) 522-4858

Designer Note:
List all telephone, electric, gas cable, etc.
Name of owner, street or PO Box, City, State,
Zip Code and Emergency Telephone Number.

G02 - UTILITY LOCATIONS

THE LOCATION OF UNDERGROUND UTILITIES SHOWN ON THE PLANS ARE AS OBTAINED FROM THE OWNERS OF UTILITIES AS REQUIRED BY SECTION 153.64 ORC. LOCATIONS AND ELEVATIONS OF EXISTING UNDERGROUND UTILITIES AND STRUCTURES SHOWN IN THE PLANS ARE APPROXIMATE ONLY. IT SHALL BE THE RESPONSIBILITY OF THE CONTRACTOR TO DETERMINE THEIR EXACT LOCATION AND ELEVATION WHEN WORKING IN THEIR VICINITY.

WHERE POTENTIAL GRADE CONFLICTS MIGHT OCCUR WITH EXISTING UTILITIES, THE CONTRACTOR SHALL UNCOVER SUCH UTILITIES SUFFICIENTLY IN ADVANCE OF CONSTRUCTION IN ORDER THAT THE EXACT ELEVATION MAY BE DETERMINED AND THE NECESSARY ADJUSTMENTS MADE. COST OF THE ABOVE, IF ANY, WILL BE INCLUDED IN THE PRICE BID FOR THE PERTINENT ITEM.

LOCATION, SUPPORT, PROTECTION AND RESTORATION OF ALL UTILITY LINES, SERVICES AND APPURTENANCES SHALL BE THE RESPONSIBILITY OF THE CONTRACTOR. THE COST OF THIS WORK SHALL BE INCLUDED WITH THE PRICE BID FOR THE PERTINENT ITEM, UNLESS OTHERWISE NOTED ON THE PLANS. ESTIMATED QUANTITIES SHOWN ON THE PLANS FOR WATER AND SANITARY SEWER RELOCATIONS ARE FOR THOSE ITEMS ACTUALLY CALLED FOR AND SHOWN ON THE PLANS.

G03 - SURVEYS

THE CONTRACTOR SHALL BE RESPONSIBLE FOR PERFORMING ALL DETAIL SURVEYS NEEDED FOR CONSTRUCTION.

G04 - MODIFICATIONS

ANY MODIFICATIONS OR CHANGES TO THE WORK, AS SHOWN ON THE DRAWINGS, MUST HAVE PRIOR WRITTEN APPROVAL BY THE CITY ENGINEER, CITY OF HEATH.

Designer Note:
Note required on all projects.

G05 - SAFETY

THE CONTRACTOR SHALL SOLELY BE RESPONSIBLE FOR COMPLYING WITH ALL FEDERAL, STATE AND LOCAL SAFETY REQUIREMENTS, TOGETHER WITH EXERCISING PRECAUTIONS AT ALL TIMES FOR THE PROTECTION OF PERSONS INCLUDING EMPLOYEES AND PROPERTY. IT IS ALSO THE CONTRACTOR'S RESPONSIBILITY TO INITIATE, MAINTAIN AND SUPERVISE ALL SAFETY REQUIREMENTS PRECAUTIONS AND PROGRAMS IN CONNECTION WITH THE WORK.

THE CONTRACTOR SHALL BE SOLELY RESPONSIBLE FOR SECURING THE PROJECT SITE FROM THE GENERAL PUBLIC BOTH DURING AND AFTER HIS WORKING HOURS. THE CONTRACTOR SHALL PROVIDE, ERECT AND MAINTAIN ALL LIGHTS, SIGNS, FENCES OR ANY OTHER SAFETY DEVICE TO PREVENT UNAUTHORIZED PERSONNEL FROM HAZARDOUS OR DANGEROUS CONDITIONS ON THE PROJECT SITE. THE COST OF SUCH WORK SHALL BE INCLUDED IN THE VARIOUS ITEMS BID FOR FURNISHING AND INSTALLING MATERIALS ON THIS PROJECT.

G06 - REVIEW OF PROJECT SITE

PRIOR TO BIDDING THE CONTRACTOR SHALL, BY PERSONAL EXAMINATION, SATISFY HIMSELF AS TO THE LOCATION OF THE PROPOSED WORK AND TO ACQUAINT HIMSELF THOROUGHLY WITH THE EXISTING CONDITIONS AND THE DIFFICULTIES THAT ARE LIKELY TO BE ENCOUNTERED IN THE PERFORMANCE OF THE PROPOSED WORK.

G07 - IRON PINS AND MONUMENTS

THE CONTRACTOR SHALL REFERENCE ALL IRON PINS AND MONUMENTS BEFORE EXCAVATING AT OR NEAR THEM. IF ANY IRON PINS OR MONUMENTS ARE DESTROYED OR DAMAGED BY THE CONTRACTOR, THEY SHALL BE ACCURATELY REPLACED BY A REGISTERED SURVEYOR EMPLOYED BY THE CONTRACTOR AT THE COMPLETION OF THE PROJECT AND AT NO EXPENSE TO THE CITY OR THE PROPERTY OWNER.

G08 PRIOR TO COMMENCEMENT OF WORK:

A PRECONSTRUCTION CONFERENCE SHALL BE HELD WITH THE CONTRACTOR, THE CITY OF HEATH, PROJECT ENGINEER, THE DEVELOPER/OWNER, AND THE CITY ENGINEER BEFORE ANY CONSTRUCTION BEGINS. AT THE PRECONSTRUCTION CONFERENCE, THE CONTRACTOR SHALL SUBMIT A PROPOSED SCHEDULE REFLECTING ALL WORK THAT IS TO BE CONDUCTED AND SECURE ANY NECESSARY LICENSES.

THE DEVELOPER/OWNER SHALL SECURE ALL NECESSARY PERMITS, PAY ANY INSPECTION, TAP, OR CONNECTION FEES. NO CONNECTION TO ANY CITY OWNED LINE SHALL BE MADE UNTIL THESE ITEMS HAVE BEEN RECEIVED BY THE CITY.

THE CONTRACTOR SHALL NOTIFY THE CITY OF HEATH ZONING DEPARTMENT A MINIMUM OF FIVE (5) DAYS BEFORE BEGINNING WORK, HOLIDAYS AND WEEKENDS EXCLUDED. WHEN THE CONTRACTOR SUSPENDS OPERATIONS FOR TWO(2)OR MORE WORKING DAYS, HE SHALL NOTIFY THE CITY ENGINEER A MINIMUM OF TWENTY-FOUR(24) HOURS BEFORE RESUMING WORK.

AT LEAST SEVENTY-TWO HOURS PRIOR TO COMMENCING CONSTRUCTION OPERATIONS IN AN AREA WHICH MAY INVOLVE UNDERGROUND UTILITY FACILITIES, THE CONTRACTOR SHALL NOTIFY THE REGISTERED UTILITY PROTECTION SERVICE AND THE OWNERS OF EACH UTILITY FACILITY SHOWN IN THE PLANS.

Designer Note:
Note required on all projects.

G09 - CONSTRUCTION STAKING

ALL CONSTRUCTION STAKING SHALL BE DONE BY OR UNDER THE DIRECTION OF A PROFESSIONAL REGISTERED SURVEYOR.

Designer Note:
Note required on all projects.

G10 - SANITARY FACILITIES

THE CONTRACTOR SHALL FURNISH AND MAINTAIN SANITARY CONVENIENCE FACILITIES FOR THE WORKERS AND INSPECTORS FOR THE DURATION OF THE WORK.

Designer Note:
Note required on all projects.

G11 - LEGAL DIMENSION AND WEIGHT LIMITS

PURSUANT TO SECTIONS 5577.04 AND 5577.05 OHIO REVISED CODE (ORC), LEGAL LIMITS FOR DIMENSIONS AND WEIGHTS FOR HIGHWAY VEHICLES WERE AMENDED EFFECTIVE OCTOBER 1, 1992. THE AMENDED ORC MAY AFFECT THE CONTRACTOR'S COST FOR PERFORMING THE VARIOUS ITEMS OF WORK ON THIS PROJECT. IT SHALL BE THE CONTRACTOR'S RESPONSIBILITY TO FACTOR ANY ADDITIONAL COSTS RESULTING FROM THE AMENDED ORC INTO THE UNIT BID PRICE FOR THE VARIOUS ITEMS OF WORK TO BE PERFORMED ON THIS PROJECT. NO ADDITIONAL REIMBURSEMENT FOR THE COSTS WILL BE PAID BY THE DEVELOPER OR CITY.

Designer Note:
Note required on all projects.

G12 - CONTINGENCY QUANTITIES

THE CONTRACTOR SHALL NOT ORDER MATERIALS NOR PERFORM WORK LISTED IN THE GENERAL SUMMARY FOR ITEMS DESIGNATED BY PLAN NOTE TO BE USED "AS DIRECTED BY THE ENGINEER." PAYMENT FOR THESE ITEMS WILL BE MADE ONLY WHEN THE WORK UNDER THE PARTICULAR ITEM HAS BEEN PERFORMED.

G13 - USE OF FIRE HYDRANTS

THE CONTRACTOR IS HEREBY NOTIFIED THAT THE USE OF FIRE HYDRANTS WILL NOT BE PERMITTED AND THAT THE USE OF FIRE HYDRANTS WILL RESULT IN THE CONTRACTOR'S PROSECUTION FOR THEFT OF A PUBLIC UTILITY. THE CONTRACTOR SHALL COORDINATE WITH THE DIVISION OF WATER TO ACCESS THE CITY'S WATER SUPPLY.

Designer Note:
Note required on all projects.

G14 - EMERGENCY PHONE NUMBER

THE CONTRACTOR SHALL PROVIDE THE CITY OF HEATH WITH A 24 HOUR TELEPHONE NUMBER TO READILY CONTACT A RESPONSIBLE PARTY IN THE CASE OF AN EMERGENCY. COSTS AND/OR DAMAGES INCURRED RELATED TO WORK PERFORMED BY THE CONTRACTOR IN SUCH EMERGENCIES ARE THE CONTRACTOR'S RESPONSIBILITY AND NOT THAT OF THE CITY OF HEATH.

Designer Note:
Note required on all projects.

G15 - INCLUSIVE BID

THE CONTRACTOR'S BID SHALL INCLUDE ALL LABOR, MATERIALS, AND EQUIPMENT REQUIRED TO COMPLETE THE PROJECT. COMPENSATION FOR ANY WORK WHICH DOES NOT HAVE A SPECIFIC PAY ITEM WILL BE INCLUDED IN THE PRICE BID FOR THE INDIVIDUAL ITEMS.

G16A - WORKING HOURS - PRIVATE

WORKING HOURS ARE LIMITED TO 7:00AM TO 7:00PM MONDAY THROUGH FRIDAY & 7:00AM TO 5:00PM ON SATURDAY. NO WORK SHALL BE PERFORMED ON SUNDAY OR CITY OF HEATH HOLIDAYS WITHOUT PRIOR WRITTEN APPROVAL. IF THE CONTRACTOR NEEDS TO WORK ON A SUNDAY OR A HOLIDAY, HE SHALL SUBMIT HIS REQUEST STATING THE REASONS FOR WORKING THOSE DAYS TO THE CITY A MINIMUM OF TWO BUSINESS DAYS PRIOR TO THE HOLIDAY OR SUNDAY.

Designer Note:
Note required on all private projects.

G16B - WORKING HOURS - PUBLIC

WORKING HOURS ARE LIMITED TO 7:00AM TO 5:30PM MONDAY THROUGH FRIDAY. THE CITY MUST HAVE 48 HOURS NOTICE BEFORE WORK CAN BEGIN THAT REQUIRES INSPECTION. NO WORK SHALL BE PERFORMED ON WEEKENDS OR CITY OF HEATH HOLIDAYS WITHOUT PRIOR WRITTEN APPROVAL. IF THE CONTRACTOR NEEDS TO WORK ON A WEEKEND OR A HOLIDAY, HE SHALL SUBMIT HIS REQUEST STATING THE REASONS FOR WORKING THOSE DAYS TO THE CITY A MINIMUM OF TWO BUSINESS DAYS PRIOR TO THE HOLIDAY OR WEEKEND.

Designer Note:
Note required on all projects with public work.

G17 - ESTIMATED QUANTITIES

THE QUANTITIES LISTED IN THE "GENERAL SUMMARY" ARE APPROXIMATE ONLY, AND SHALL BE USED IN DETERMINING THE TOTAL AMOUNTS OF BIDS FOR THE PURPOSE OF DETERMINING THE LOWEST AND BEST BIDDER. THE QUANTITIES MAY BE INCREASED OR DIMINISHED AT THE OPTION OF THE ENGINEER.

G18 RECORD DRAWINGS

THE CONTRACTOR SHALL PREPARE AND MAINTAIN A SET OF RECORD CONSTRUCTION DRAWINGS AS HIS WORK ON THE PROJECT PROGRESSES. THE RECORD DRAWINGS SHALL DOCUMENT ALL DEVIATIONS FROM THE ORIGINAL DRAWINGS AS WELL AS DOCUMENT THE LOCATION AND EXTENT OF ANY UNFORESEEN CONDITIONS OR OBSTRUCTIONS. THE RECORD CONDITIONS SHALL BE SHOWN IN RED AND ANY PLAN CHANGES SHALL BE OUTLINED. THE CONTRACTOR SHALL BRING THE RECORD DRAWINGS TO ALL CONSTRUCTION PROGRESS MEETINGS FOR THE CITY'S REVIEW.

THE DEVELOPER IS RESPONSIBLE FOR HAVING 2 FULL SIZE, 3 HALF SIZE, AND ELECTRONIC COPIES OF THE RECORD CONSTRUCTION DRAWINGS SENT TO THE CITY AFTER THE PROJECT IS COMPLETED. THE PLANS MUST INCLUDE THE FOLLOWING:

a) LOCATIONS, TOP-OF-CASTINGS, AND FLOW LINE ELEVATIONS FOR ALL SANITARY AND STORM SEWER STRUCTURES, ALONG WITH SERVICE LATERAL LOCATIONS. b) LOCATIONS OF ALL WATER LINES, VALVES, HYDRANTS, AND SERVICES. c) IDENTIFY ALL FIELD MODIFICATIONS TO THE APPROVED PLAN SET.

THE DEVELOPER SHALL ALSO PROVIDE THE CITY WITH ELECTRONIC CADD FILES OF THE RECORD DRAWINGS IN ORDER TO INCORPORATE THE PROJECT INTO THE CITY GIS. THE CADD FILE COORDINATE SYSTEM SHALL BE STATE PLANE SOUTH, NAD 83, NAVD 88.

Designer Note:
Note required on all projects.

ITEM SPECIAL - RECORD CONSTRUCTION DRAWINGS

THE CONTRACTOR SHALL PREPARE AND MAINTAIN A SET OF RECORD CONSTRUCTION DRAWINGS AS HIS WORK ON THE PROJECT PROGRESSES. THE RECORD DRAWINGS SHALL DOCUMENT ALL DEVIATIONS FROM THE ORIGINAL DRAWINGS AS WELL AS DOCUMENT THE LOCATION AND EXTENT OF ANY UNFORESEEN CONDITIONS OR OBSTRUCTIONS. THE RECORD CONDITIONS SHALL BE SHOWN BY IN RED AND ANY PLAN CHANGES SHALL BE OUTLINED. THE CONTRACTOR SHALL BRING THE RECORD DRAWINGS TO ALL CONSTRUCTION PROGRESS MEETINGS FOR THE CITY ENGINEER'S REVIEW.

THE CONTRACTOR SHALL COMPLETE AND SUBMIT 2 COPIES OF THE RECORD DRAWINGS WITH THE CITY FOR REVIEW UPON SUBSTANTIAL COMPLETION OF THE PROJECT. UPON REVIEW AND ACCEPTANCE BY THE CITY, THE CONTRACTOR WILL SUBMIT A FINAL COPY ON MYLAR. THE CITY WILL WITHHOLD THE FINAL PAYMENT TO THE CONTRACTOR UNTIL THE RECORD DRAWINGS HAVE BEEN SUBMITTED. FINAL RECORD DRAWINGS SHALL CONTAIN THE FOLLOWING:

- a) LOCATIONS, TOP-OF-CASTINGS, AND FLOW LINE ELEVATIONS FOR ALL SANITARY AND STORM SEWER STRUCTURES, ALONG WITH SERVICE LATERAL LOCATIONS.
- b) LOCATIONS OF ALL WATER LINES, VALVES, HYDRANTS, AND SERVICES.
- c) IDENTIFY ALL FIELD MODIFICATIONS TO THE APPROVED PLAN SET.

Designer Note:
This note to be used on public projects. All public projects shall be on State Plane Coordinates, scaled about the origin.

G19 - SHOP DRAWINGS AND/OR PRODUCT DATA

THE CONTRACTOR SHALL SUBMIT FOR THE PROJECT REPRESENTATIVE'S APPROVAL, FOUR COPIES OF THE SHOP DRAWINGS AND/OR PRODUCT DATA. ALLOW 15 DAYS FOR REVIEW AND APPROVAL. TWO COPIES OF THE APPROVED SHOP DRAWINGS AND/OR PRODUCT DATA WILL BE RETAINED BY THE PROJECT REPRESENTATIVE AND TWO COPIES WILL BE RETURNED TO THE CONTRACTOR.

G20 - NON-RUBBER TIRE VEHICLES

NO NONRUBBER TIRE VEHICLES SHALL BE MOVED ON CITY STREETS. EXCEPTIONS MAY BE GRANTED BY THE CITY WHERE SHORT DISTANCES AND SPECIAL CIRCUMSTANCES ARE INVOLVED. GRANTING OF EXCEPTIONS MUST BE IN WRITING AND ANY RESULTING DAMAGE MUST BE REPAIRED TO THE SATISFACTION OF THE CITY. THE CONTRACTOR SHALL USE EXTREME CARE WHEN OPERATING NONRUBBER TIRE VEHICLES ON STREETS OR DRIVEWAYS TO AVOID MARKING OR DAMAGING THE PAVEMENT. PROTECTION OF THE PAVEMENT FROM DAMAGE RESULTING FROM THE TRACKS OF NON-RUBBER TIRE VEHICLES UTILIZED IN TRENCH EXCAVATION SHALL BE REQUIRED. A WOOD PLANK SYSTEM, USED TIRES, RUBBER MATS OR OTHER MEANS AS APPROVED BY THE CITY'S REPRESENTATIVE SHALL BE USED TO PROTECT THE PAVEMENT. THE COST OF THIS WORK SHALL BE INCLUDED IN THE UNIT PRICE BID FOR THE VARIOUS ITEMS OF THE CONTRACT.

Designer Note:
Note required on all projects.

G22 - PROTECTION AND RESTORATION OF PROPERTY

THE CONTRACTOR IS RESPONSIBLE FOR THE PROTECTION AND RESTORATION OF ALL PRIVATE AND PUBLIC PROPERTY IMPACTED BY THE CONTRACTOR'S OPERATIONS IN ACCORDANCE WITH 107.10.

Designer Note:
Note required on all projects.

G23 WORK LIMITS

THE CONTRACTOR SHALL CONFINE HIS ACTIVITIES TO THE PROJECT SITE UNDER DEVELOPMENT OR THE EXISTING RIGHT-OF-WAYS, CONSTRUCTION AND/OR PERMANENT EASEMENTS AND SHALL NOT TRESPASS UPON OTHER PRIVATE PROPERTY WITHOUT THE WRITTEN CONSENT OF THE OWNER.

G26 - MISCELLANEOUS WORK

ALL ITEMS OF WORK CALLED FOR ON THE PLANS FOR WHICH NO SPECIFIC METHOD OF PAYMENT IS PROVIDED SHALL BE PERFORMED BY THE CONTRACTOR AND THE COST OF SAME SHALL BE INCLUDED IN THE PRICE BID FOR THE VARIOUS RELATED ITEMS.

G27 - FINAL CLEAN-UP

THE CONTRACTOR SHALL CLEAN UP ALL DEBRIS AND MATERIALS RESULTING FROM HIS OPERATIONS AND RESTORE ALL SURFACES, STRUCTURES, DITCHES, AND PROPERTY TO ITS ORIGINAL CONDITION TO THE SATISFACTION OF THE CITY.

G29 - PERFORMANCE BOND

THE CONTRACTOR SHALL FURNISH A PERFORMANCE BOND IN AN AMOUNT EQUAL TO 100% OF THE CONTRACT PRICE MADE PAYABLE TO THE CITY TO INSURE THE AVAILABILITY OF FUNDS TO COMPLETE THE PROJECT. THE COST OF THE BOND SHALL BE INCLUDED IN THE PRICE OF THE VARIOUS ITEMS.

Designer Note:
Note shall be used on public project. All private projects shall see Section 70.00 of Development Regulations.

G30 INDEMNIFICATION

THE CONTRACTOR WILL INDEMNIFY AND HOLD HARMLESS THE CITY AND THE ENGINEER AND THEIR AGENTS AND EMPLOYEES FROM AND AGAINST ALL CLAIMS, DAMAGES, LOSSES AND EXPENSES INCLUDING ATTORNEYS' FEES ARISING OUT OF OR RESULTING FROM PERFORMANCE OF THE WORK, PROVIDED THAT ANY SUCH CLAIMS, DAMAGE, LOSS OR EXPENSE IS ATTRIBUTABLE TO BODILY INJURY, SICKNESS, DISEASE OR DEATH, OR INJURY TO OR DESTRUCTION OF TANGIBLE PROPERTY, INCLUDING THE LOSS OF USE RESULTING THEREFROM; AND IS CAUSED IN WHOLE OR IN PART BY ANY NEGLIGENT OR WILLFUL ACT OR OMISSION OF THE CONTRACTOR, AND SUBCONTRACTOR, ANYONE DIRECTLY OR INDIRECTLY EMPLOYED BY ANY OF THEM OR ANYONE FOR WHOSE ACTS ANY OF THEM MAY BE LIABLE.

IN ANY AND ALL CLAIMS AGAINST THE CITY OR THE ENGINEER, OR ANY OF THEIR AGENTS OR EMPLOYEES, BY ANY EMPLOYEE OF THE CONTRACTOR, ANY SUBCONTRACTOR, ANYONE FOR WHOSE ACTS ANY OF THEM MAY BE LIABLE, THE INDEMNIFICATION OBLIGATION SHALL NOT BE LIMITED IN ANY WAY BY ANY LIMITATION ON THE AMOUNT OR TYPE OF DAMAGES, COMPENSATION OR BENEFITS PAYABLE BY OR FOR THE CONTRACTOR OR ANY SUBCONTRACTOR UNDER WORKERS COMPENSATION ACTS, DISABILITY BENEFIT ACTS, OR OTHER EMPLOYEE BENEFIT ACTS.

THE OBLIGATION OF THE CONTRACTOR UNDER THIS PARAGRAPH SHALL NOT EXTEND TO THE LIABILITY OF THE ENGINEER, HIS AGENTS OR EMPLOYEES ARISING OUT OF THE PREPARATION OR APPROVAL OF MAPS, PLANS, OPINIONS, REPORTS, SURVEYS, CHANGE ORDERS, DESIGNS OR SPECIFICATIONS.

G31 PAVING OVER VALVES AND MANHOLES

NO MANHOLE OR VALVE BOX IS TO BE COVERED IN THE STREET WHEN PAVING A CITY STREET.

G32 - PAVEMENT CLEANING

THE CONTRACTOR IS HEREBY NOTIFIED THAT HE/SHE SHALL BE RESPONSIBLE FOR CLEANING OF STREETS OR ANY MUD, DIRT, SAND, GRAVEL, STONES, OR ANY KIND OF MATERIAL THAT HAVE DEPOSITED AS A RESULT OF HIS/HER OR SUB-CONTRACTOR'S OPERATIONS. PAVEMENTS SHALL BE CLEANED AT THE END OF EACH WORK DAY OR MORE OFTEN AS DETERMINED BY THE CITY ENGINEER OR HIS REPRESENTATIVE.

Designer Note:
Note required on all projects.

G33 - DUST CONTROL

THE CONTRACTOR IS ADVISED THAT HIS WORK WILL BE IN PROXIMITY TO OCCUPIED RESIDENCES. THEREFORE, IT IS EXPECTED THE CONTRACTOR WILL PERFORM HIS/HER EARTHWORK OPERATIONS TO MINIMIZE DUST. WHEN CONDITIONS ARE SUCH THAT DUST BECOMES A MAJOR PROBLEM OR AS ADVISED BY THE CITY, THE CONTRACTOR WILL APPLY A DUST PALLIATIVE PER ITEM 616.

G34 - CONSTRUCTION NOISE

ACTIVITIES AND LAND USE ADJACENT TO THIS PROJECT MAY BE AFFECTED BY CONSTRUCTION NOISE. IN ORDER TO MINIMIZE ANY ADVERSE CONSTRUCTION NOISE IMPACTS, ANY POWER-OPERATED CONSTRUCTION-TYPE DEVICE SHALL NOT BE OPERATED BETWEEN THE HOURS OF 9:00PM AND 7:00AM. IN ADDITION, ANY SUCH NOISE SHALL NOT BE OPERATED AT ANY TIME IN SUCH A MANNER THAT THE NOISE CREATED SUBSTANTIALLY EXCEEDS THE NOISE CUSTOMARILY AND NECESSARILY ATTENDANT TO THE REASONABLE AND EFFICIENT PERFORMANCE OF SUCH EQUIPMENT.

ITEM 624 - MOBILIZATION, AS PER PLAN

IN ADDITION TO THE WORK REQUIRED UNDER ITEM 624 MOBILIZATION, THE FOLLOWING WORK SHALL BE INCLUDED IN THE LUMP SUM PRICE BID FOR THIS ITEM:

BEFORE ANY WORK BEGINS, THE CONTRACTOR SHALL THOROUGHLY VIDEOTAPE THE PROJECT AREA. THE PURPOSE OF THE VIDEOTAPE IS TO ESTABLISH A BENCHMARK OF THE PRE-CONSTRUCTION CONDITION OF THE PROJECT AREA, ESPECIALLY OF THE SURROUNDING PRIVATE PROPERTY. IN THE EVENT OF AN ADJOINING PROPERTY OWNER MAKES A CLAIM FOR DAMAGES RESULTING FROM THE PERFORMANCE OF THE WORK, THE VIDEOTAPE WILL BE USED TO DETERMINE THE LEGITIMACY OF THAT CLAIM. THE CONTRACTOR SHALL USE DUE DILIGENCE IN PERFORMING THIS OPERATION TO MEET THE STATED PURPOSE. THE VIDEOTAPE SHALL BE IN VHS FORMAT WITH SOUND TO ALLOW THE PERSON OPERATING THE RECORDER TO ADD COMMENTARY AS THE AREA IS RECORDED. THE CONTRACTOR SHALL SUBMIT ONE COPY OF EACH VIDEOTAPE OF THE PROJECT AREA TO THE ENGINEER.

G36 - PROTECTION OF WORK SITE

THE CONTRACTOR SHALL PROVIDE, INSTALL AND MAINTAIN SUFFICIENT TRAFFIC CONTROL DEVICES OR METHODS TO PREVENT UNAUTHORIZED USE OF THE NEW STREET PRIOR TO ACCEPTANCE BY THE CITY. THE CONTRACTOR SHALL SUBMIT HIS MAINTENANCE OF TRAFFIC PLAN TO THE ENGINEER FOR APPROVAL PRIOR TO BEGINNING WORK. THE COST FOR THIS WORK SHALL BE INCLUDED IN THE LUMP SUM PRICE FOR ITEM 614, MAINTAINING TRAFFIC.

G37 - US MAIL DELIVERY

THE CONTRACTOR SHALL BE RESPONSIBLE TO ENSURE US MAIL DELIVERY WITHIN THE PROJECT LIMITS IS NOT DISRUPTED BY CONSTRUCTION OPERATIONS. THIS RESPONSIBILITY IS LIMITED TO RELOCATION OF MAILBOXES TO A TEMPORARY LOCATION THAT WILL ALLOW THE COMPLETION OF THE WORK AND SHALL ALSO INCLUDE THE RESTORATION OF MAILBOXES TO THEIR ORIGINAL LOCATION OR APPROVED NEW LOCATION. ANY RELOCATION OF MAILBOX SERVICES MUST FIRST BE COORDINATED WITH THE US POSTAL SERVICE AND THE HOME OWNER.

G38 WEATHER CONDITIONS

ALL CONSTRUCTION AND MATERIAL USAGE SHALL BE IN ACCORDANCE WITH CLIMATIC CONDITIONS ADDRESSED IN CURRENT ISSUE OF THE OHIO DEPARTMENT OF TRANSPORTATION CONSTRUCTION AND MATERIALS SPECIFICATIONS.

G39 CONCRETE COLLARS

CONTRACTOR SHALL REFER TO HEATH STANDARD DRAWINGS SA-1, SA-2, ST-1, ST-2, AND WA-3 FOR CONCRETE COLLARS TO BE PLACED AROUND VALVE BOXES AND MANHOLES.

CITY OF HEATH
DIRECTOR OF BUILDING AND ZONING

DATE
10-2005
12-2005
02-2015
10-2017
01-2021
03-2022

STANDARD CONSTRUCTION DRAWING
GENERAL SPECIFICATIONS & NOTES

NUMBER
GEN-0

DATE: - TIME: - USERNAME: - FILES

ST01 - ITEM 204 - PROOF ROLLING

AN ESTIMATED QUANTITY FOR THIS ITEM HAS BEEN PROVIDED IN THE GENERAL SUMMARY. THE CONTRACTOR SHALL PROOF ROLL THE ROADBED IN THE PRESENCE OF REPRESENTATIVES OF THE CITY OF HEATH STREET DEPARTMENT. THE CONTRACTOR SHALL NOTIFY THE STREET DEPARTMENT 2 DAYS IN ADVANCE OF THE PROOF ROLLING.

Designer Note:

This note is intended for use on all projects where the proposed roadway will become a public street.

ST02 - ASPHALT PRODUCTION

THE CONTRACTORS ASPHALT PLANT SHALL BE OHIO DEPARTMENT OF TRANSPORTATION INSPECTED AND APPROVED AS PER ODOT 402 SPECIFICATIONS. ASPHALT MUST BE PRODUCED IN A PLANT WITH A COMPUTERIZED PLANT SYSTEM, APPROVED BY ODOT, AS PER 402.07. THE CONTRACTOR MUST HAVE AN ODOT APPROVED QUALITY PROGRAM AS PER 403.03.

SECTION 401.20 "ASPHALT BINDER PRICE ADJUSTMENT" SHALL NOT APPLY TO THIS PROJECT.

ST03 - DRIVE CULVERTS

PIPE MATERIAL SHALL BE AS PER 2010 ODOT ITEM 603, TYPE D, 706.02 AND 707.33.

BEDDING SHALL BE AS PER 2010 ODOT ITEM 603.

BACKFILL SHALL BE AS PER 2010 ODOT ITEM 304.

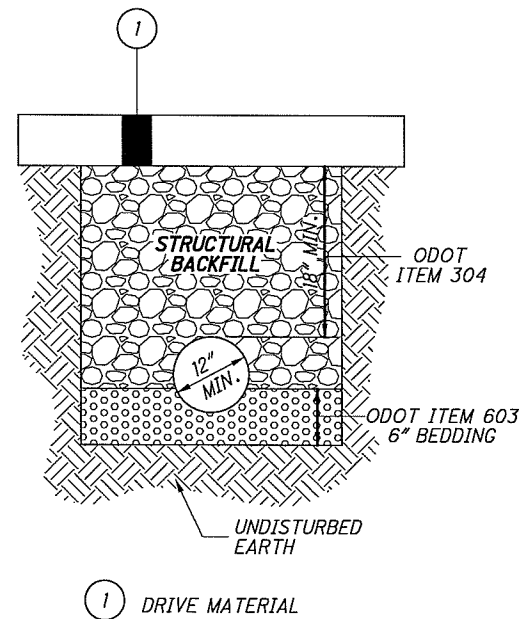

ST04 - STORM SEWERS

PIPE MATERIAL SHALL BE AS PER 2010 ODOT ITEM 603, 706.02 AND 707.33.

BEDDING AND BACKFILL SHALL BE AS PER 2010 ODOT ITEM 603, TYPE B OR TYPE C DEPENDING ON LOCATION.

CITY OF HEATH
Scott G. Galt
 STREET SUPERINTENDENT

DATE
 10-2005
 8-2006
 02-2012
 01-2021

STANDARD CONSTRUCTION DRAWING
 ROADWAY AND DRAINAGE SPECIFICATIONS & NOTES

NUMBER
 RD-0

1 / 1

LEGEND

- 1 ITEM 441 - 1/4" ASPHALT CONCRETE SURFACE COURSE, TYPE 1, (448), PG64-22
- 2 ITEM 441 - 1/4" ASPHALT CONCRETE INTERMEDIATE COURSE, TYPE 2, (448)
- 3 ITEM 301 - 4" ASPHALT CONCRETE BASE
- 4 ITEM 204 - SUBGRADE COMPACTION
- 5 ITEM 407 - TACK COAT @ 0.075 GAL/SQ YD
- 6 ITEM 407 - TACK COAT FOR INTERMEDIATE COURSE @ 0.04 GAL/SQ YD
- 7 omitted
- 8 ITEM 609 - COMBINED CURB AND GUTTER, TYPE B (HEATH)
- 9 ITEM 609 - CONCRETE CURB TYPE 6 (ODOT)
- 10 ITEM 659 - SEEDING AND MULCHING CLASS I
- 11 ITEM 608 - 4" CONCRETE WALK
- 12 ITEM 301 - 6" ASPHALT CONCRETE BASE
- 13 ITEM 304 - 8" AGGREGATE BASE
- 14 ITEM 304 - 10" AGGREGATE BASE
- 15 ITEM 625 - 4" CONDUIT 725.051

NOTES

PAVEMENT THICKNESS:
 PAVEMENT THICKNESSES SHOWN ARE MINIMUM ALLOWABLE COMPACTED THICKNESSES FOR EACH COURSE. THE DESIGN ENGINEER IS TO INCREASE THICKNESS AS REQUIRED TO MEET IN-PLACE SOIL, AND ANTICIPATED TRAFFIC LOADING CONDITIONS.

REQUIRED PLAN NOTES:
 THE FOLLOWING NOTES ARE TO BE ADDED TO THE TYPICAL SHEETS OF ALL CONSTRUCTION DRAWINGS:

- CURB CONTRACTOR IS TO STAMP THE TOP/CURB WITH A "W" TO INDICATE LOCATION OF WATER SERVICE
- CURB CONTRACTOR IS TO STAMP THE TOP/CURB WITH A "S" TO INDICATE LOCATION OF SANITARY LATERAL
- **NOTE TO UTILITY OWNERS:**
 THE SIDEWALK WILL BE INSTALLED BY THE HOMEOWNER AT THE TIME OF HOME CONSTRUCTION. ALL UTILITY ITEMS (PULL BOXES, TEL. PEDESTAL, STATIONS, ETC.) SHALL BE INSTALLED AS TO NOT INTERFERE WITH THE LOCATION OF THE FUTURE SIDEWALK.

- A omitted
- B DIMENSION VARIES WHEN A TURN LANE IS REQUIRED.
- C THERE SHALL BE A MINIMUM OF 3" OF SAND ON ALL SIDES OF CONDUIT. COMPACTED GRANULAR BACKFILL UNDER PAVEMENT CROSSINGS TO EXTEND 5' BEYOND PAVEMENT. ITEM 203 - EMBANKMENT TO BE USED FOR CONDUIT NOT UNDER PAVEMENT. PULLBOXES PER 625.11 SHALL BE INSTALLED AT ALL INTERSECTIONS, BENDS, DEFLECTIONS AND AT SPACING NOT TO EXCEED 1000'.

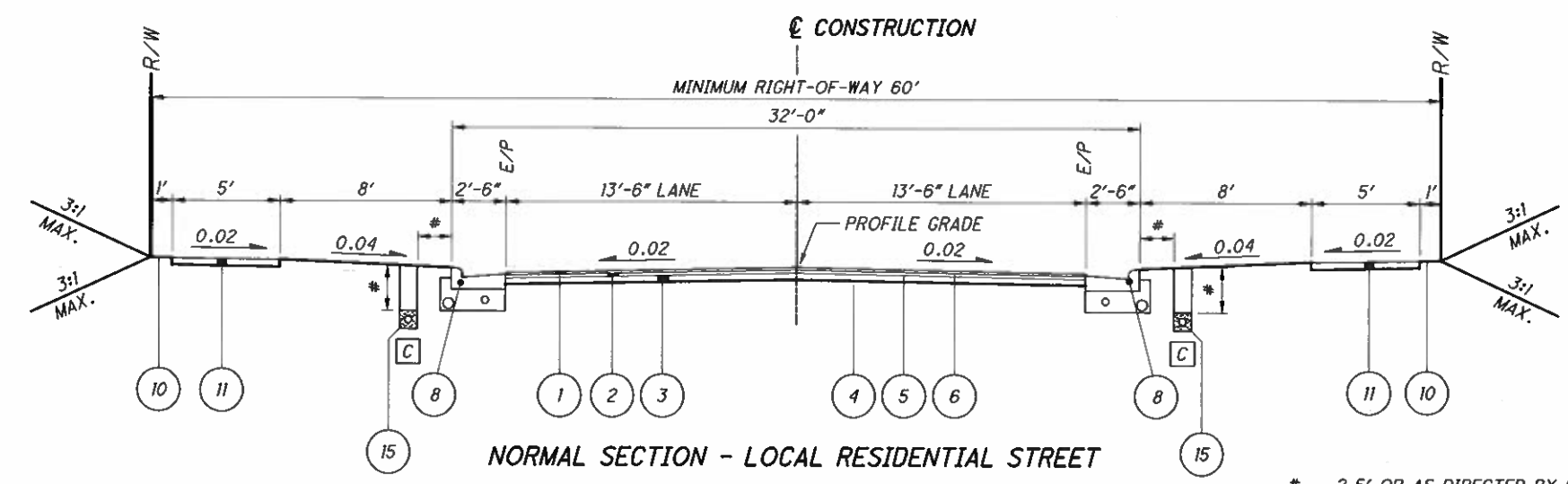

NORMAL SECTION - LOCAL RESIDENTIAL STREET

* 2.5' OR AS DIRECTED BY CITY ENGINEER

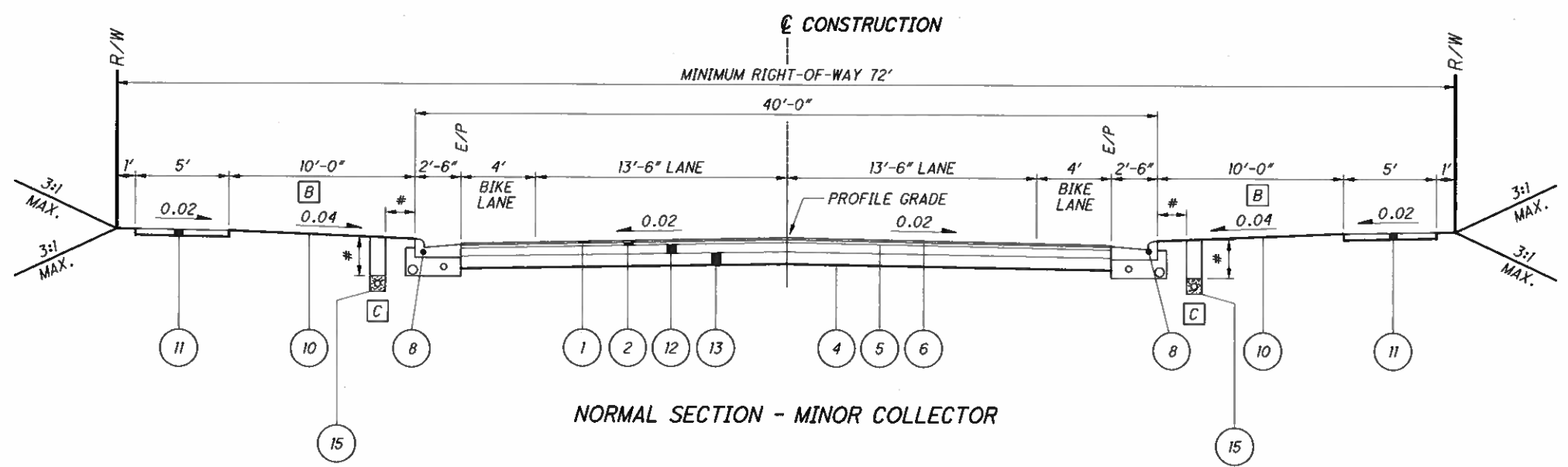

NORMAL SECTION - MINOR COLLECTOR

* 2.5' OR AS DIRECTED BY CITY ENGINEER

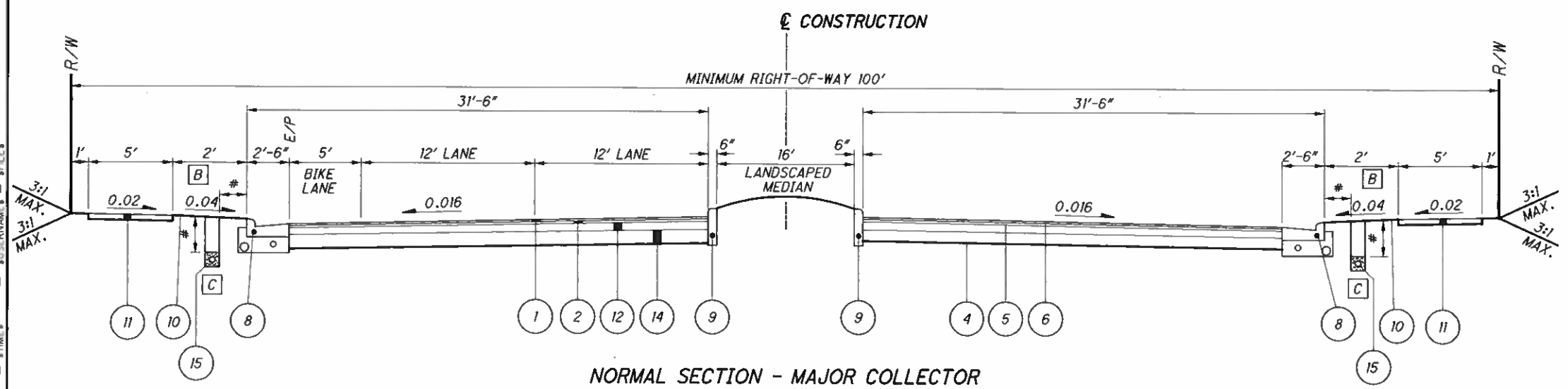

NORMAL SECTION - MAJOR COLLECTOR

* 2.5' OR AS DIRECTED BY CITY ENGINEER

\$USERNAME\$ - \$FILES\$
 \$DAYS\$ - \$TIMES\$

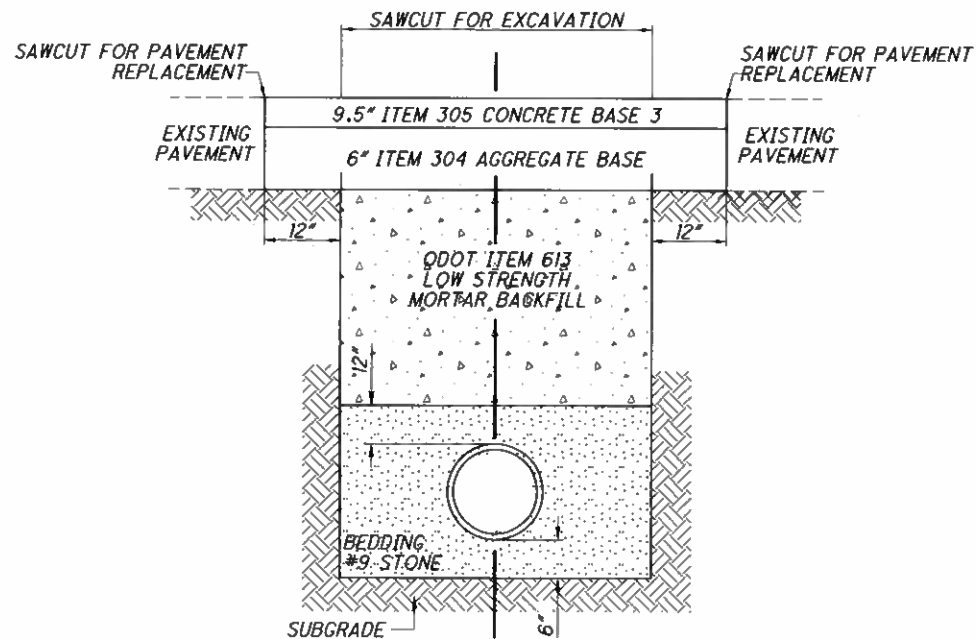

PRIVATE UTILITY TRENCH DETAIL

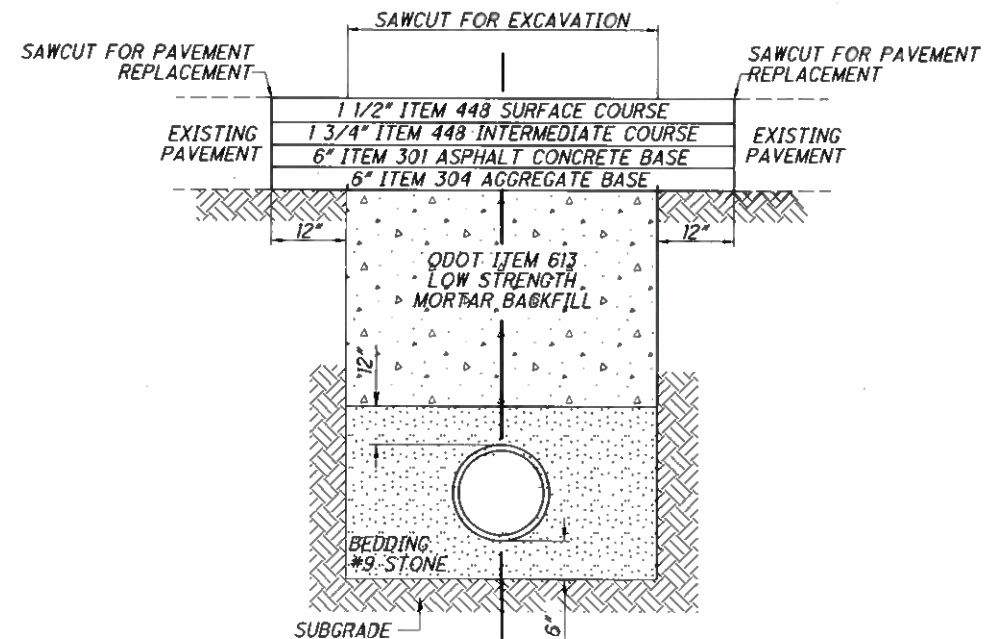

PRIVATE UTILITY TRENCH DETAIL
* ONLY TO BE UTILIZED AT THE APPROVAL OF THE CITY ENGINEER

NOTES:

1. PERMANENT PAVEMENT REPLACEMENT SHALL NOT BE PLACED UNTIL APPROVED BY THE ENGINEER.
2. ALL MATERIALS AND CONSTRUCTION SHALL CONFORM TO THE PERTINENT SECTION OF ODOT CMS.
3. EDGES OF THE EXISTING PAVEMENT SHALL BE CUT PER ITEM 255.03 VERTICAL AND TRIMMED TO PROVIDE A STRAIGHT LINE JUNCTURE BETWEEN EXISTING AND NEW PAVEMENT. NO RAGGED EDGES SHALL BE PERMITTED.
4. WHERE SAND IS USED AS BEDDING AROUND CONDUIT SUCH AS GAS, THE BEDDING SHALL NOT EXTEND MORE THAN 6 INCHES ABOVE THE CONDUIT.
5. TACK COAT SHALL MEET THE REQUIREMENTS OF ITEM 407 OR PG64-22 PER 702.01 AND SHALL BE APPLIED AT A RATE OF 0.25 GAL/SY TO THE SIDES OF THE SAWN PAVEMENT AND BASE MATERIAL BEFORE PLACING ASPHALT CONCRETE.
6. WEARING COURSE LESS THAN 2 FEET WIDE ADJACENT TO CURB OR EDGE OF PAVEMENT SHALL BE REMOVED AND REPLACED TO THE CURB OR EDGE OF PAVEMENT.
7. JOINT SEALER SHALL MEET THE REQUIREMENTS OF 702.01 PG64-22 HOT APPLIED.
8. SURFACE JOINTS SHALL BE SEALED BY A SQUEEGEE APPLICATION OF 702.01 PG64-22 ASPHALT BINDER MATERIAL AT 0.30 GAL/SQ.YD. FOLLOWED BY AN APPLICATION OF 407.02 COVER AGGREGATE .008 CU.YD/SQ.YD.
9. THE MINIMUM WIDTH OF PAVEMENT REPAIR AREA SHALL BE OF SUFFICIENT WIDTH TO ALLOW FOR THE PROPER PLACEMENT AND COMPACTION OF THE ASPHALT CONCRETE.
10. IN NO CASE SHALL THE PAVEMENT BUILDUP BE LESS THAN THE EXISTING PAVEMENT.
11. WHENEVER UNDERDRAIN IS DISTURBED IN THE COURSE OF CONSTRUCTION, IT SHALL BE REPLACED WITH ITEM 605, PIPE UNDERDRAIN OF THE SAME MATERIAL AND DIAMETER TO THE SATISFACTION OF THE CITY ENGINEER.
12. EXTEND BACKFILL 1' HORIZONTAL FROM TRENCH FOR EVERY 1' DEEP THE TRENCH IS, OR EXTEND 5', WHICHEVER IS GREATER.

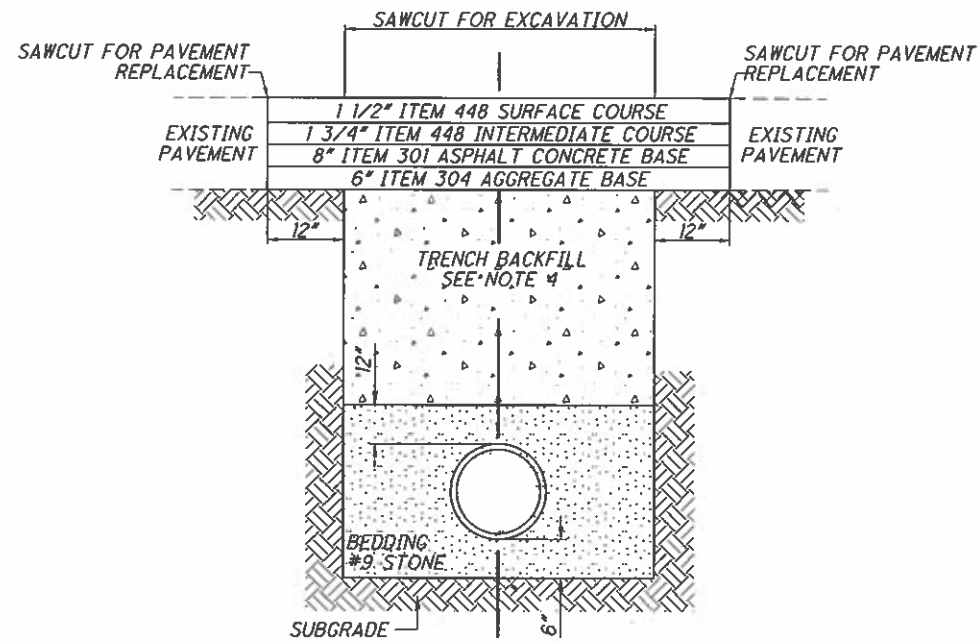

**TYPE A
ARTIAL STREET**

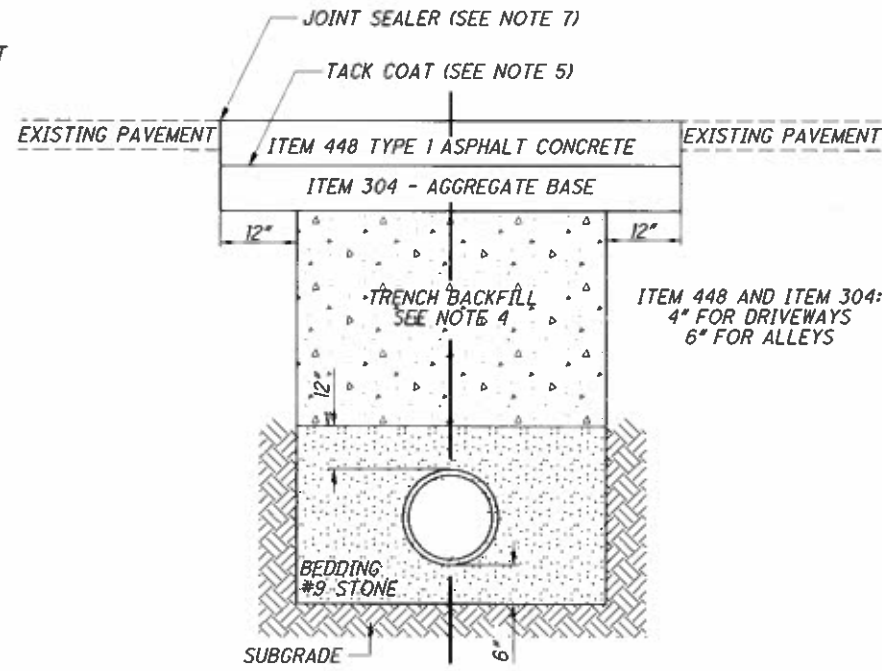

**TYPE C
ASPHALT ALLEYS AND DRIVEWAYS**

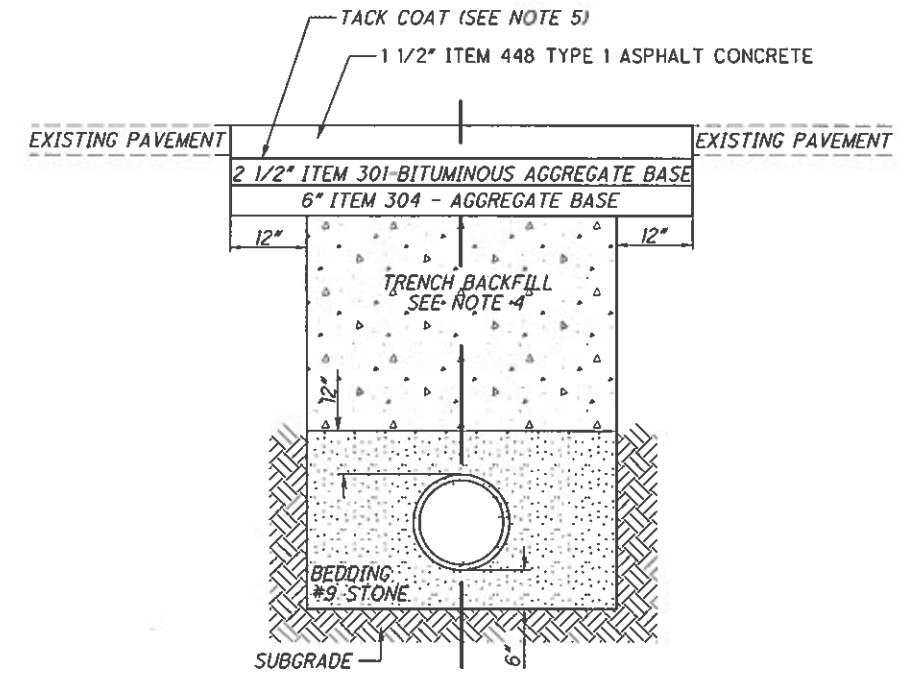

**TYPE E
ASPHALT ALLEYS, DRIVEWAYS, AND BIKEPATHS**

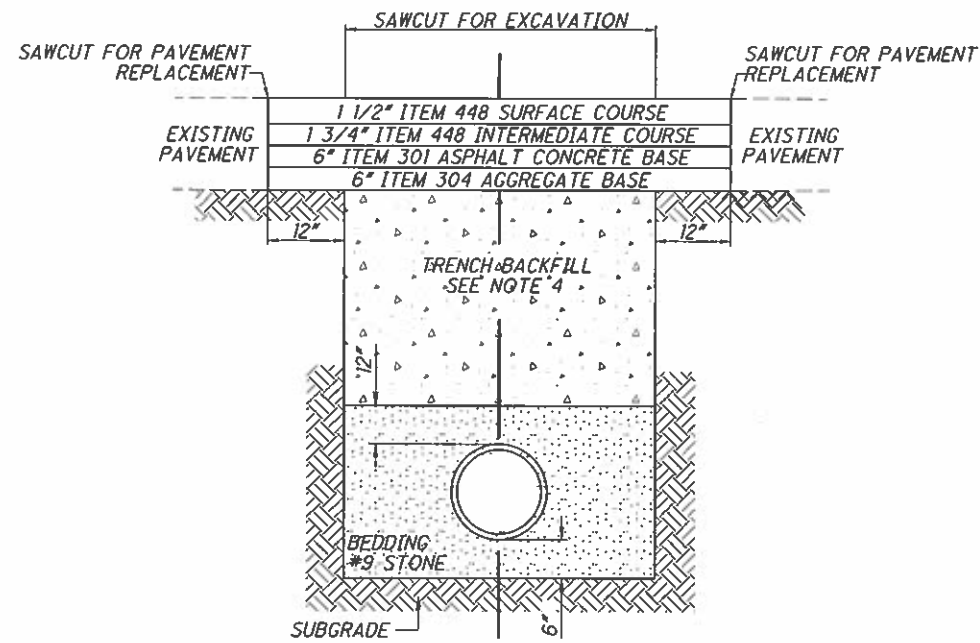

**TYPE B
LOCAL STREET**

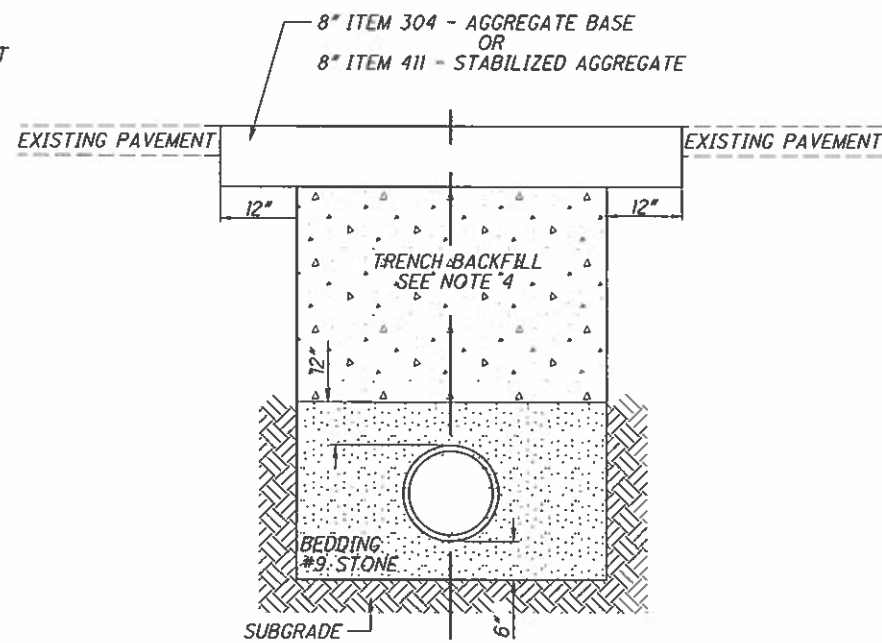

**TYPE D
GRAVEL ALLEYS AND DRIVEWAYS**

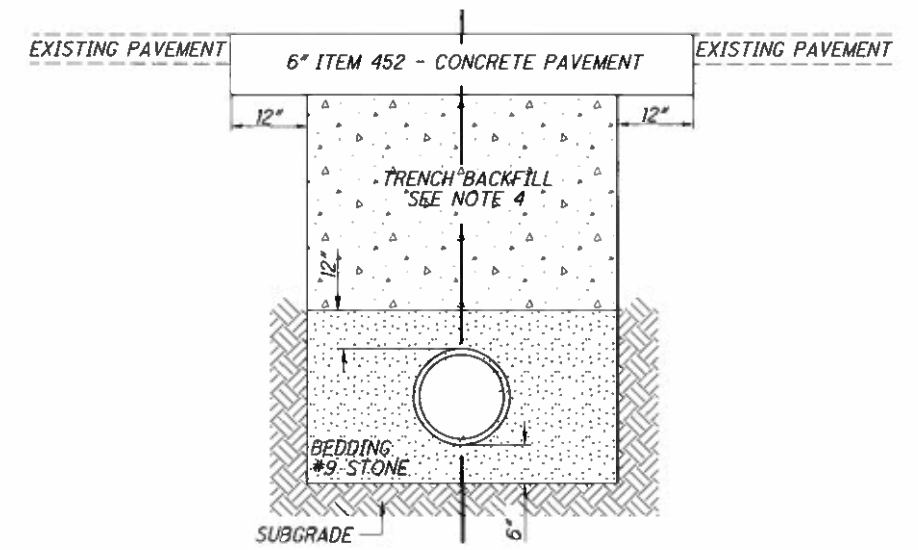

**TYPE F
CONCRETE ALLEYS AND DRIVEWAYS**

NOTES:

1. PERMANENT PAVEMENT REPLACEMENT SHALL NOT BE PLACED UNTIL APPROVED BY THE ENGINEER.
2. ALL MATERIALS AND CONSTRUCTION SHALL CONFORM TO THE PERTINENT SECTION OF ODOT CMS.
3. EDGES OF THE EXISTING PAVEMENT SHALL BE CUT PER ITEM 255.03 VERTICAL AND TRIMMED TO PROVIDE A STRAIGHT LINE JUNCTURE BETWEEN EXISTING AND NEW PAVEMENT. NO RAGGED EDGES SHALL BE PERMITTED.
4. ALL TRENCH BACK FILL SHALL BE EITHER COMPACTED GRANULAR BACK FILL PER ODOT CMS ITEM 304 OR LOW STRENGTH MORTAR BACKFILL PER ODOT CMS ITEM 613.

5. TACK COAT SHALL MEET THE REQUIREMENTS OF ITEM 407 OR PG64-22 PER 702.01 AND SHALL BE APPLIED AT A RATE OF 0.25 GAL/SY TO THE SIDES OF THE SAWN PAVEMENT AND BASE MATERIAL BEFORE PLACING ASPHALT CONCRETE.
6. WEARING COURSE LESS THAN 2 FEET WIDE ADJACENT TO CURB OR EDGE OF PAVEMENT SHALL BE REMOVED AND REPLACED TO THE CURB OR EDGE OF PAVEMENT.
7. JOINT SEALER SHALL MEET THE REQUIREMENTS OF 702.01 PG64-22 HOT APPLIED.
8. SURFACE JOINTS SHALL BE SEALED BY A SQUEEGEE APPLICATION OF 702.01 PG64-22 ASPHALT BINDER MATERIAL AT 0.30 GAL/SQ.YD. FOLLOWED BY AN APPLICATION OF 407.02 COVER AGGREGATE .008 CU.YD/SQ.YD.

9. THE MINIMUM WIDTH OF PAVEMENT REPAIR AREA SHALL BE OF SUFFICIENT WIDTH TO ALLOW FOR THE PROPER PLACEMENT AND COMPACTION OF THE ASPHALT CONCRETE.
10. IN NO CASE SHALL THE PAVEMENT BUILDUP BE LESS THAN THE EXISTING PAVEMENT BUILDUP.
11. WHENEVER UNDERDRAIN IS DISTURBED IN THE COURSE OF CONSTRUCTION, IT SHALL BE REPLACED WITH ITEM 605, PIPE UNDERDRAIN OF THE SAME MATERIAL AND DIAMETER TO THE SATISFACTION OF THE CITY ENGINEER.
12. EXTEND BACKFILL 1' HORIZONTAL FROM TRENCH FOR EVERY 1' DEEP THE TRENCH IS, OR EXTEND 5', WHICHEVER IS GREATER.

8/10/2005 11:02:12 AM stromes M:\CH2005-03 Development\Reis\CMS & STD\Road\RD-7.dgn

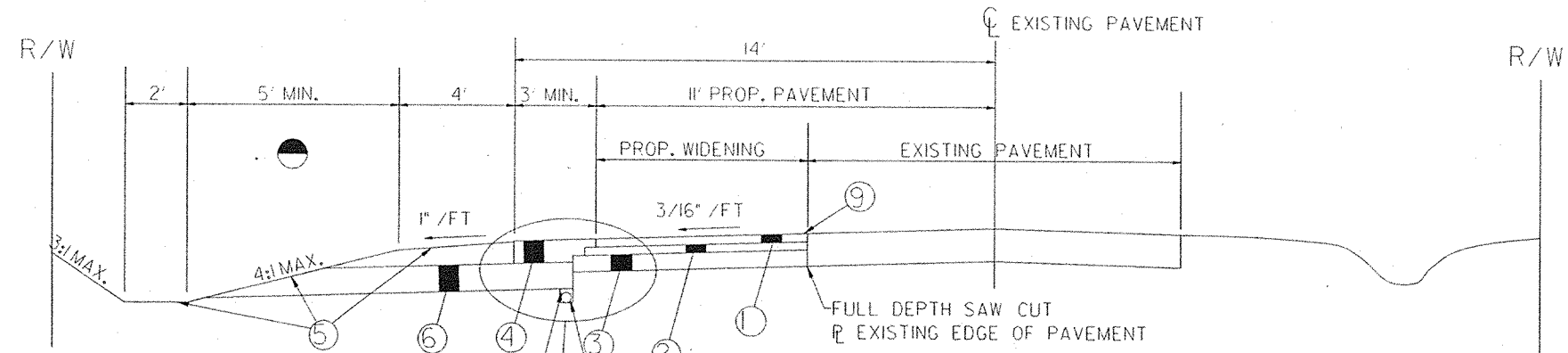

NOTES:

- ALL DIMENSIONS SHOWN ARE REQUIRED MINIMUMS.
- EXISTING FIRE HYDRANTS SHALL BE ADJUSTED AND/OR RELOCATED TO 8' OFF PROPOSED EDGE OF PAVEMENT.
- VARY IN DESIGN STAGE TO MEET THE CONDITION ON THE SITE.
METHOD "A" TO BE USED WHEN POSSIBLE.
METHOD "B" AS ALTERNATE.
- * TO BE ON A GRADE AND DRAINED INTO DITCH OR STORM SEWER SYSTEM.

- | | |
|---|--|
| ① 3" ASPHALT CONCRETE, ITEM 404 | ⑦ BITUMINOUS PRIME COAT, ITEM 408
(APPLIED AT 0.40 GAL. PER SQ. YD.) |
| ② 3" BITUMINOUS AGGREGATE BASE, ITEM 301 | ⑧ SEAL COAT, ITEM 409 (USING 0.30 GAL.
BITUMINOUS MATERIAL PER SQ. YD. AND
COVER AGGREGATE PER SQ. YD.). |
| ③ 6" AGGREGATE BASE, ITEM 304 | ⑨ JOINT SEAL, ITEM 413 |
| ④ 8" AGGREGATE BERM, ITEM 304 | |
| ⑤ SEEDING AND MULCHING, ITEM 659 | |
| ⑥ 8" AGGREGATE UNDERDRAIN, ITEM 605
(SPACED EVERY 50') | |

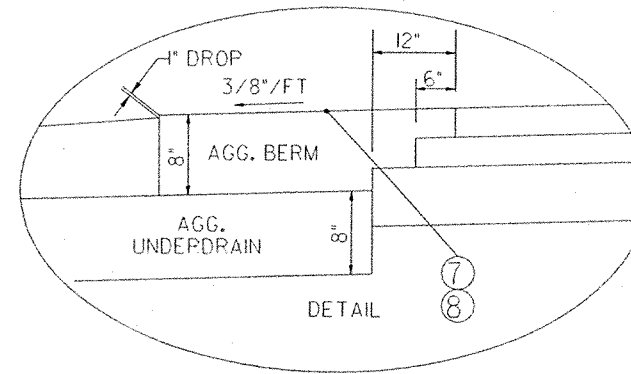

NUMBER
RD-7

STANDARD CONSTRUCTION DRAWING
TYPICAL SECTION: PAVEMENT WIDENING

DATE
05-1997

CITY OF HEATH
J. Penrose
STREET SUPERINTENDENT

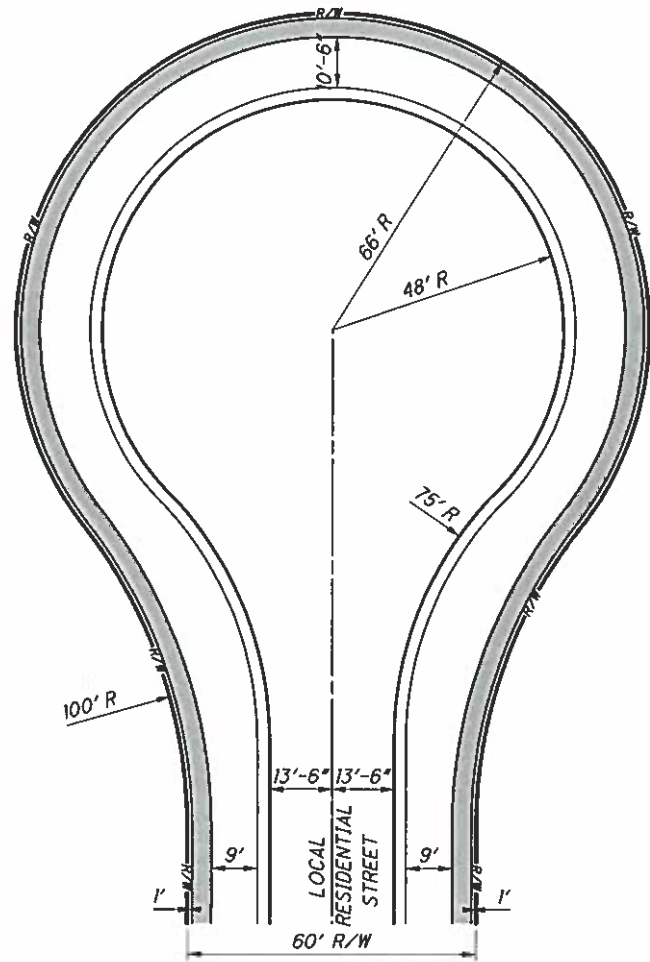

RESIDENTIAL CUL-DE-SAC

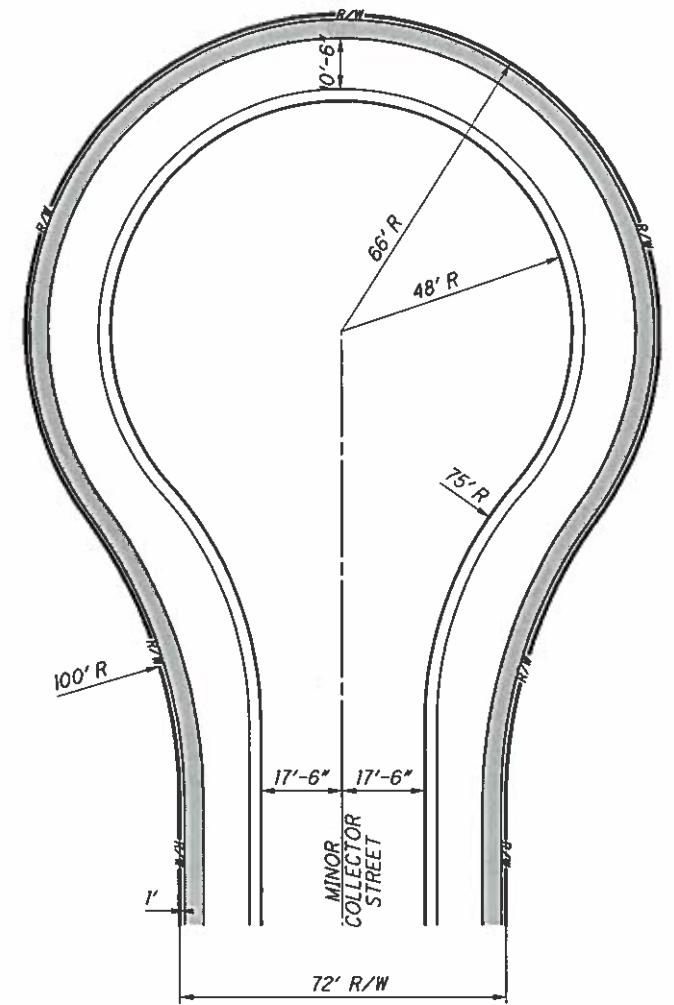

COMMERCIAL CUL-DE-SAC

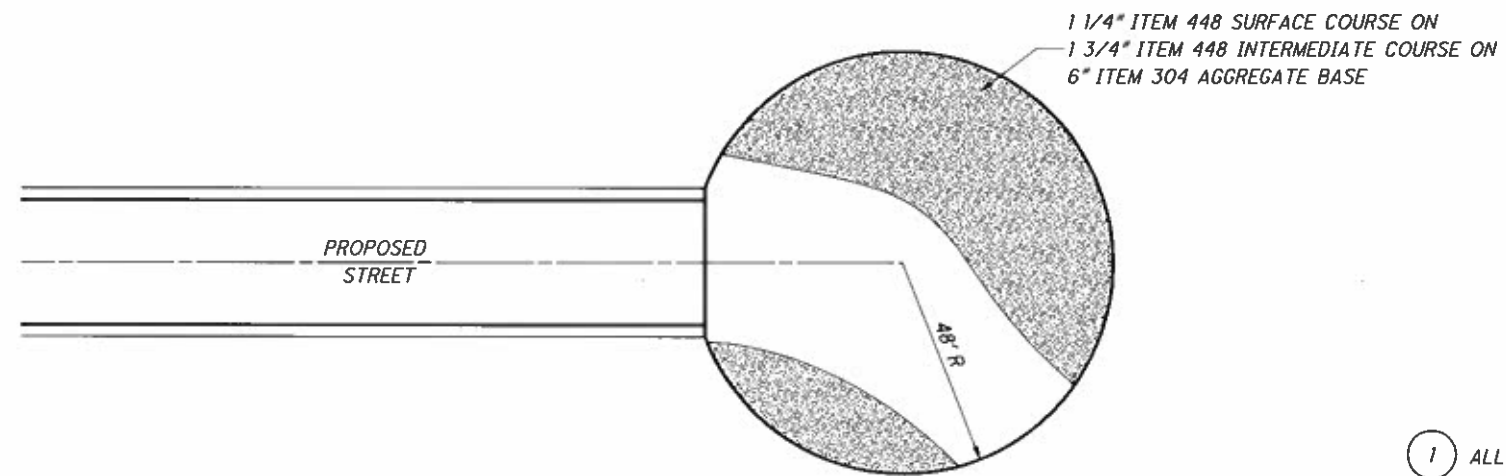

TEMPORARY TURNAROUND

NOTES:

- 1 ALL CUL-DE-SACS SHALL BE SIGNED AS NO PARKING.
SIGNAGE SHALL BE AS PER THE ODOT TRAFFIC ENGINEERING MANUAL AND THE OHIO MANUAL OF UNIFORM TRAFFIC CONTROL DEVICES.

DATES — TIMES — USERNAMES — FILES

STANDARD CONSTRUCTION DRAWING
 CUL-DE-SAC & TEMPORARY TURNAROUND DETAIL

NUMBER
 RD-8

1 / 1

DATE
 05-1997
 10-2005
 03-2022

CITY OF HEATH
Bob Gull
 STREET SUPERINTENDENT

NOTES:

- 1 CONCRETE CURB AND GUTTER IS TO BE IN ACCORDANCE WITH ODOT ITEM NO. 609.
- 2 COMPACTION UNDER CONCRETE CURB AND GUTTER IS TO BE IN ACCORDANCE WITH ODOT ITEM NO. 203
- 3 4" PERFORATED UNDERDRAIN (IF SPECIFIED) IS TO BE IN ACCORDANCE WITH ODOT ITEM NO. 605. UNDERDRAIN IS TO BE CONNECTED TO THE STORM SEWER SYSTEM WITH THE CURB AND GUTTER INLETS.
- 4 2"-3" OF TOPSOIL PER ODOT ITEM NO. 653 AND SEEDED AND MULCHED PER ODOT ITEM NO 659.
- 5 BUTT JOINTS SHALL BE PROVIDED BETWEEN COMBINED CURB AND GUTTER AND NEW OR EXISTING RIGID PAVEMENTS, WITH TIE BARS OR HOOKS PROVIDED AT INTERVALS OF 5'. SEE ODOT STANDARD CONSTRUCTION DRAWING BP-2.1 FOR DETAILS OF TIE BARS AND HOOK BOLTS.

IF THE COMBINED CURB AND GUTTER ADJOINS A NEW RIGID BASE OR AN EXISTING RIGID BASE OR PAVEMENT THAT IS TO BE SURFACED WITH BITUMINOUS MATERIAL, A BUTT JOINT SHALL BE OMITTED WHEN THE VERTICAL OVERLAP (4" IN DETAIL BELOW) BETWEEN THE CURB AND GUTTER AND RIGID PAVEMENT IS LESS THAN 7".

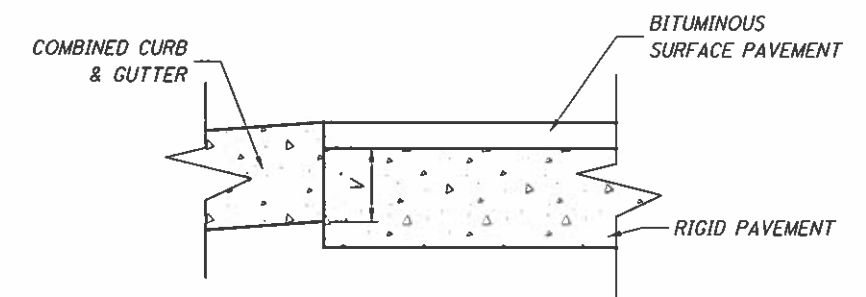

- 6 SAWING AND SEALING ASPHALT CONCRETE PAVEMENT JOINTS SHALL BE IN ACCORDANCE WITH ODOT ITEM 409.

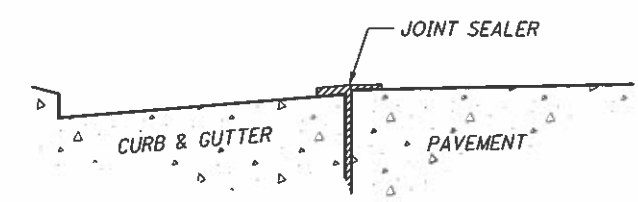

- 7 ALL 6" SDR 26 DRAIN TILES ARE REQUIRED IN ALL RESIDENTIAL AREAS AND SHALL HAVE A CLEAN OUT EVERY 400'. ALL DOWNSPOUTS ARE REQUIRED TO CONNECT TO 6" PIPE.

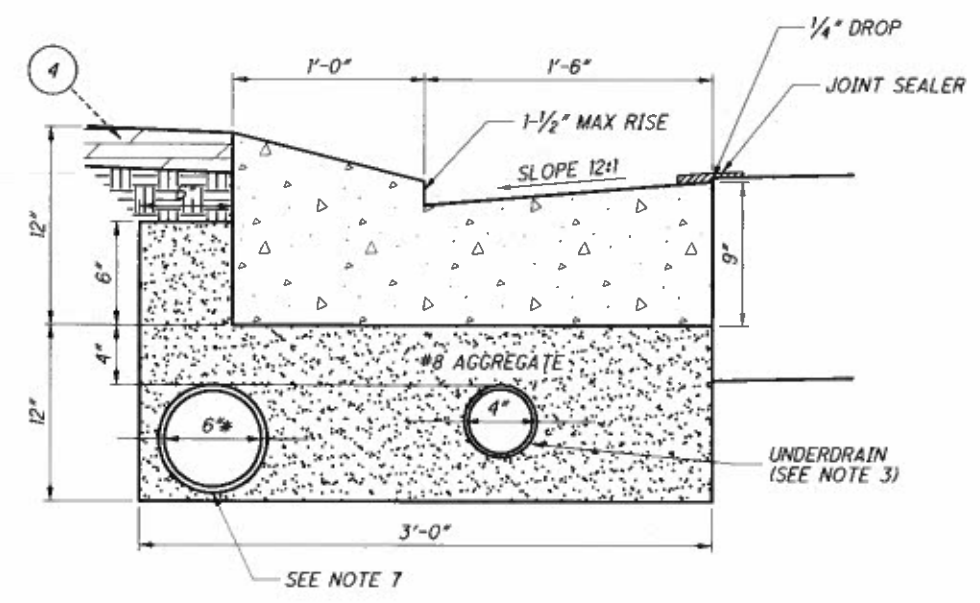

TYPE A

** ONLY FOR REPLACEMENT CURB **

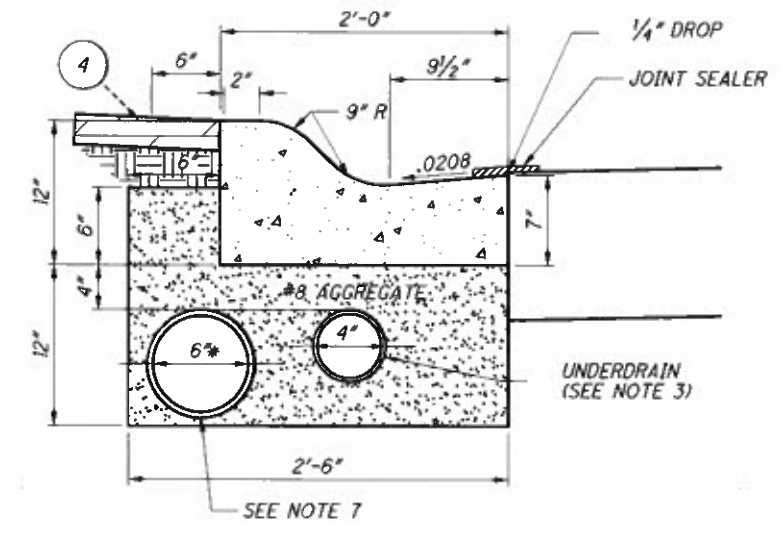

TYPE C

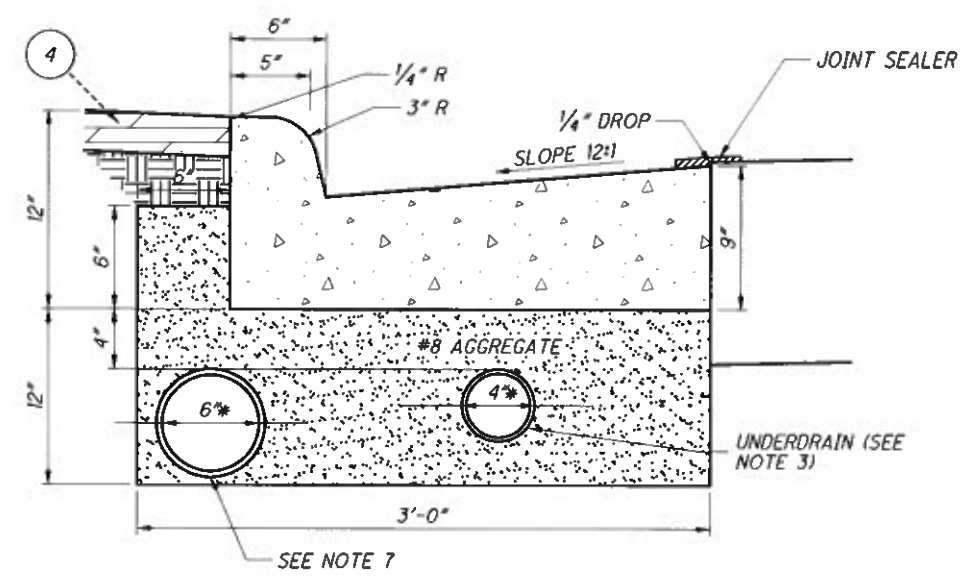

TYPE B

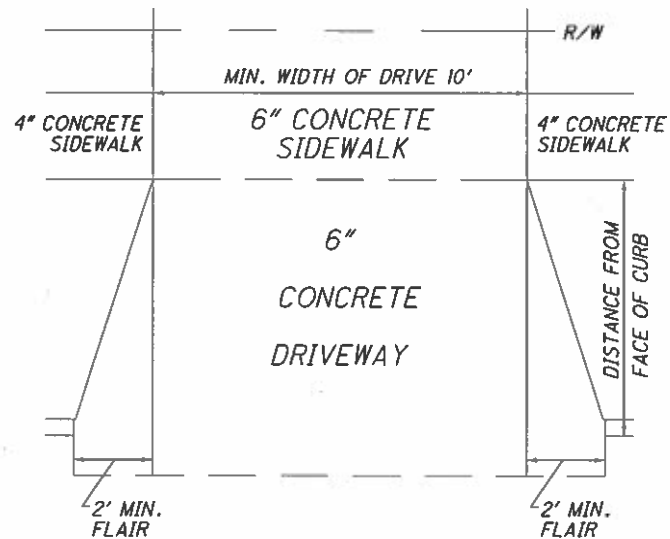

$CURB CUT = WIDTH OF DRIVE + 4' (MIN.)$

NOTES:

1. FILLS, IF REQUIRED, SHALL BE OF EARTH, COMPACTED IN 2" LAYERS, OR OF ITEM 304, SUBBASE, COMPACTED IN LAYERS NOT EXCEEDING 4".
2. DRIVEWAYS AND SIDEWALKS SHALL BE CONSTRUCTED OF PLAIN PORTLAND CEMENT CONCRETE, ITEM 452.
3. EXPANSION JOINTS SHALL BE PLACED TO FORM UTILITY STRIPS WHERE REQUIRED, AND WHEREVER NEW CONCRETE TOUCHES EXISTING CONSTRUCTION.
4. FORMS SHALL CONSIST OF WOOD 2" NOMINAL THICKNESS OR METAL OF EQUAL STRENGTH.

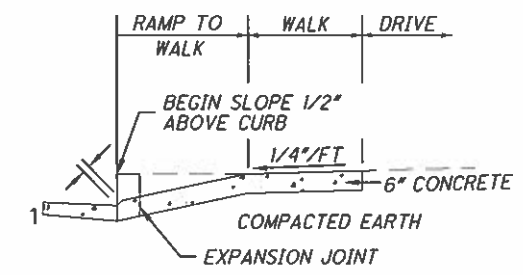

STANDARD COMBINED CURB AND GUTTER SECTION

5. A STANDARD CURING COMPOUND SHALL BE PROPERLY APPLIED IMMEDIATELY AFTER FINISH.
6. ALTERNATE ASPHALT CONCRETE RAMP, INSTEAD OF PLAIN PORTLAND CEMENT CONCRETE THE PORTIONS OF THE DRIVEWAY OUTSIDE OF THE LIMITS OF THE SIDEWALK MAY BE CONSTRUCTED TO THESE MINIMUM REQUIREMENTS:
 ODOT ITEM 304 - 4" AGGREGATE BASE,
 ODOT ITEM 441 - 3" ASPHALT CONCRETE INTERMEDIATE COURSE, TYPE 2, (448)
 ODOT ITEM 441 - 2" ASPHALT CONCRETE SURFACE COURSE, TYPE 1, (448), PG64-22M
7. * CURB SHALL BE CONSTRUCTED IN MINIMUM 5' SECTIONS AND MAXIMUM 10' SECTIONS.

\$DATE\$ - \$TIME\$ - \$USER\$NAME\$ - \$FILES\$

CITY OF HEATH
Bob Gull
 STREET SUPERINTENDENT

DATE
 05-1997
 01-2021
 03-2022

STANDARD CONSTRUCTION DRAWING
 RESIDENTIAL DRIVEWAY

NUMBER
 RD-13

1 / 1

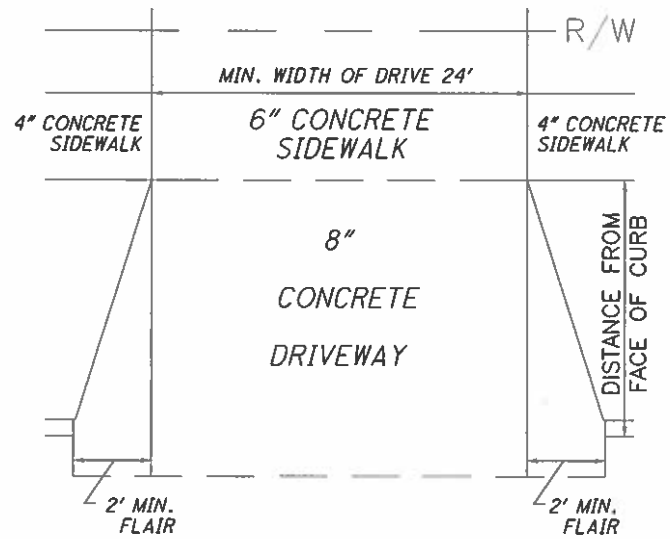

CURB CUT = WIDTH OF DRIVE + 4' (MIN.)

NOTES:

1. FILLS, IF REQUIRED, SHALL BE OF EARTH, COMPACTED IN 2" LAYERS, OR OF ITEM 304, SUBBASE, COMPACTED IN LAYERS NOT EXCEEDING 4".
2. DRIVEWAYS AND SIDEWALKS SHALL BE CONSTRUCTED OF PLAIN PORTLAND CEMENT CONCRETE, ITEM 452.
3. EXPANSION JOINTS SHALL BE PLACED TO FORM UTILITY STRIPS WHERE REQUIRED, AND WHEREVER NEW CONCRETE TOUCHES EXISTING CONSTRUCTION.
4. FORMS SHALL CONSIST OF WOOD 2" NOMINAL THICKNESS OR METAL OF EQUAL STRENGTH.

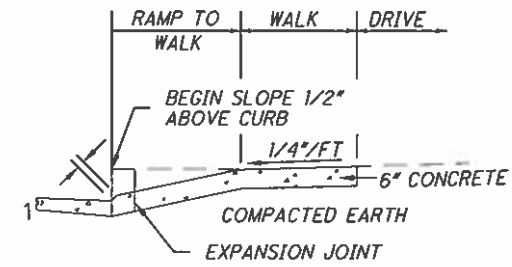

STANDARD COMBINED CURB AND GUTTER SECTION

5. A STANDARD CURING COMPOUND SHALL BE PROPERLY APPLIED IMMEDIATELY AFTER FINISH.
6. ALTERNATE ASPHALT CONCRETE RAMP, INSTEAD OF PLAIN PORTLAND CEMENT CONCRETE THE PORTIONS OF THE DRIVEWAY OUTSIDE OF THE LIMITS OF THE SIDEWALK MAY BE CONSTRUCTED TO THESE MINIMUM REQUIREMENTS:
 ODOT ITEM 304 - 4" AGGREGATE BASE,
 ODOT ITEM 301 - 3" ASPHALT CONCRETE
 ODOT ITEM 441 - 2" ASPHALT CONCRETE INTERMEDIATE COURSE, TYPE 2, (448)
 ODOT ITEM 441 - 1.5" ASPHALT CONCRETE SURFACE COURSE, TYPE 1, (448), PG70-22M
7. * CURB SHALL BE CONSTRUCTED IN MINIMUM 5' SECTIONS AND MAXIMUM 10' SECTIONS.

DATES - TIMES - USERNAMES - FILES

CITY OF HEATH
Bill Heath
 STREET SUPERINTENDENT

DATE
 05-1997
 01-2021
 03-2022

STANDARD CONSTRUCTION DRAWING
 COMMERCIAL DRIVEWAY

NUMBER
 RD-14

1 / 1

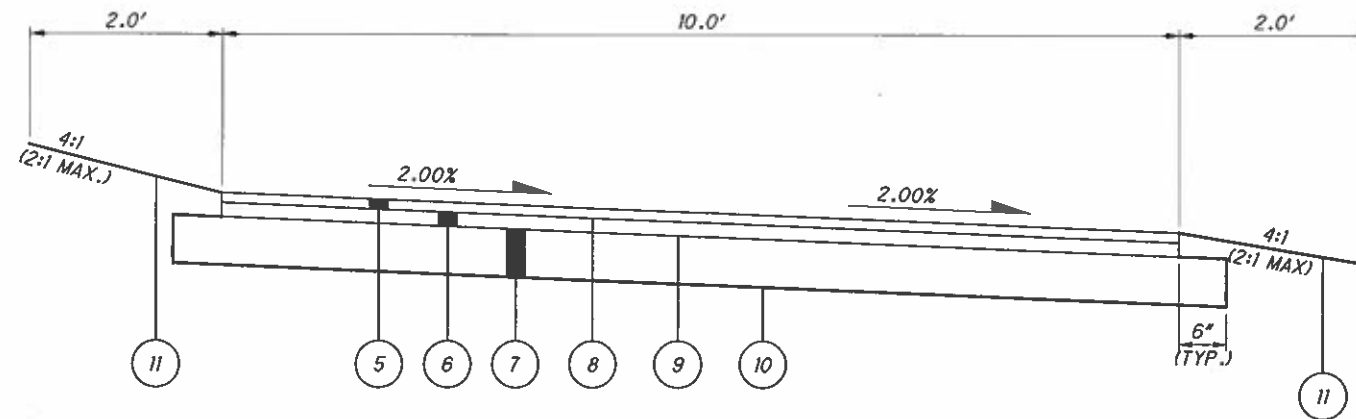

BIKE / SHARED USE TRACK

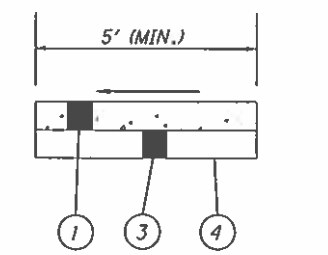

WITHIN DRIVEWAY AREA

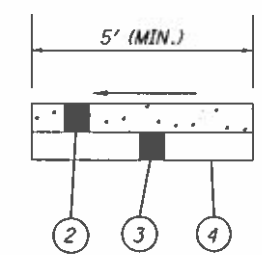

OTHER AREAS

NOTES:

1. ALL CONCRETE SHALL BE PLACED IN ONE POUR AND FINISHED WITH A WOOD FLOAT.
2. EXPANSION JOINTS SHALL BE PLACED WHEREVER NEW CONCRETE TOUCHES EXISTING CONSTRUCTION AND AT INTERVALS OF 30' OR LESS.
3. WATER AND GAS VALVE BOXES WITH IN SIDEWALK AREA SHALL BE ADJUSTED TO PROPER GRADE.
4. FORMS SHALL BE MADE OF LUMBER 2" NOMINAL THICKNESS OR EQUALLY RIGID METAL.

- ① 6" PLAIN PORTLAND CEMENT CONCRETE, ODOT ITEM 452
- ② 4" PLAIN PORTLAND CEMENT CONCRETE, ODOT ITEM 452
- ③ 4" STONE, ODOT ITEM 304
- ④ SUBGRADE COMPACTION, ODOT ITEM 203
- ⑤ 1 1/4" ASPHALT CONCRETE SURFACE COURSE, TYPE 1, PG64-22, ODOT ITEM 448
- ⑥ 1 3/4" ASPHALT CONCRETE INTERMEDIATE COURSE, TYPE 2, PG64-22, ODOT ITEM 448
- ⑦ 6" AGGREGATE BASE, ODOT ITEM 304
- ⑧ TACK COAT (0.075 GAL/SQ YD), ODOT ITEM 407
- ⑨ TACK COAT (0.040 GAL/SQ YD), ODOT ITEM 407
- ⑩ SUBGRADE COMPACTION, ODOT ITEM 204
- ⑪ SEEDING AND MULCHING, CLASS 1, ODOT ITEM 659

DATES - TIMES - SUSERNAME\$ - \$FILES

DATE
 05-1997
 03-2022

8/10/2005 11:05:22 AM - shaines - M:\CH2005-03 Development\Reqs\CMS & STD\Drawings\ST-3.dgn

NOTES:

- I. ALL CURB INLETS OVER 4' DEEP SHALL HAVE MANHOLE APPROVED STEPS.

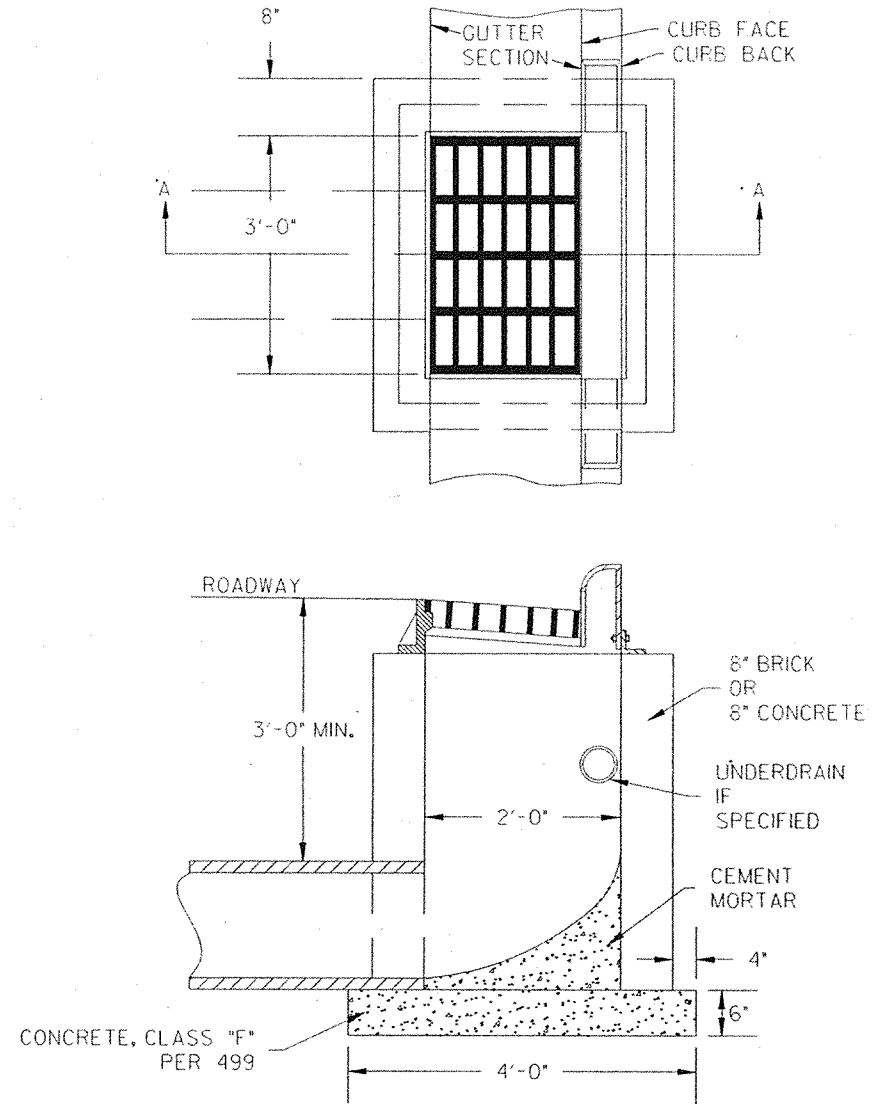

CITY OF HEATH
J. Lawrence
STREET SUPERINTENDENT

DATE
05-1997

STANDARD CONSTRUCTION DRAWING
CURB AND GUTTER INLET

NUMBER
ST-3

1 / 1

8/10/2005 11:05:38 AM - shaines - M:\CH2005-03 Development Reqs\CMS & STD\Drainage\ST-4.dgn

CATCH BASIN SIZE	OUTLET PIPE SIZE
3'	12" TO 33"
4'	36" TO 42"

NOTES:

1. OPENINGS FOR PIPES SHALL BE O.D. +2" WHEN PREFABRICATED OR FIELD CUT.
2. REINFORCING IN THE TOP TO BE No. 4 BARS 6" CENTER TO CENTER. FOR STANDARD 3' CATCH BASIN USE 8 BARS AND FOR STANDARD 4' CATCH BASIN USE 12 BARS.
3. SIDE INLETS SHALL BE PROVIDED ONLY WHEN SPECIFIED ON THE PLANS.
4. GRATES SHALL BE NEENAH 3246 CASTINGS WITH "V" GRATES

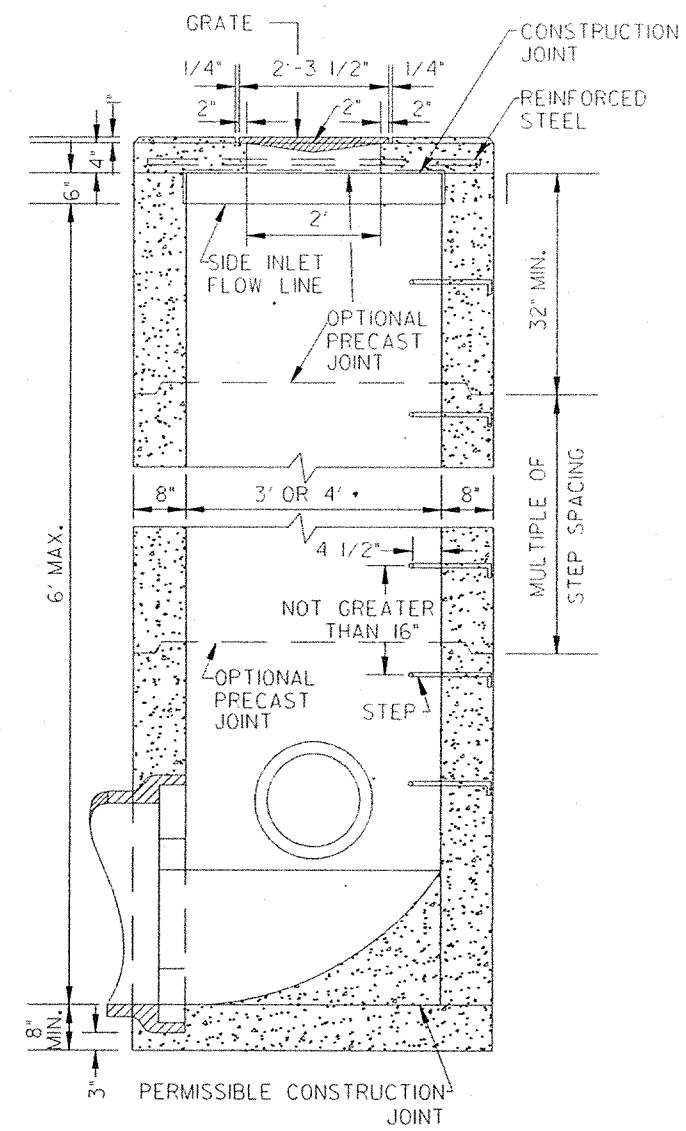

NUMBER
ST-4

STANDARD CONSTRUCTION DRAWING
STANDARD CATCH BASIN

DATE
05-1997

CITY OF HEATH
J. P. ...
STREET SUPERINTENDENT

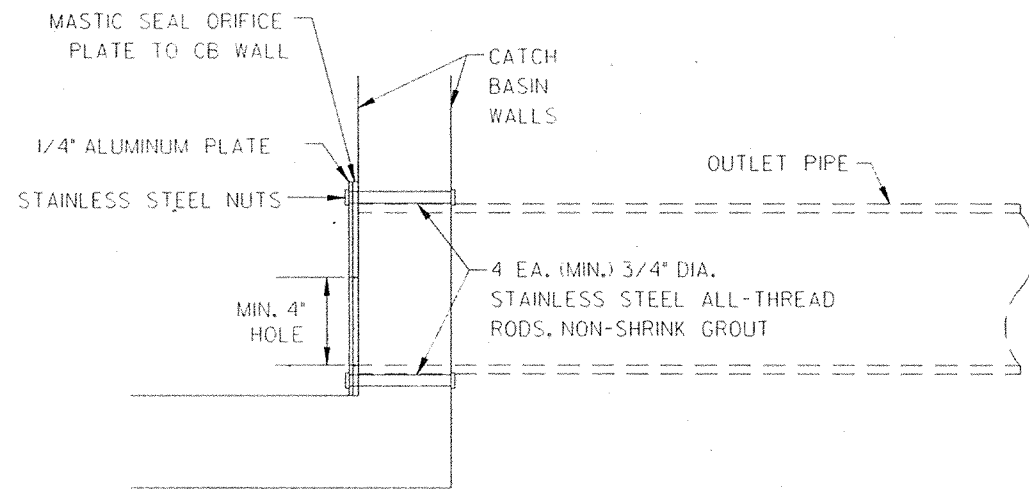

SIDE VIEW

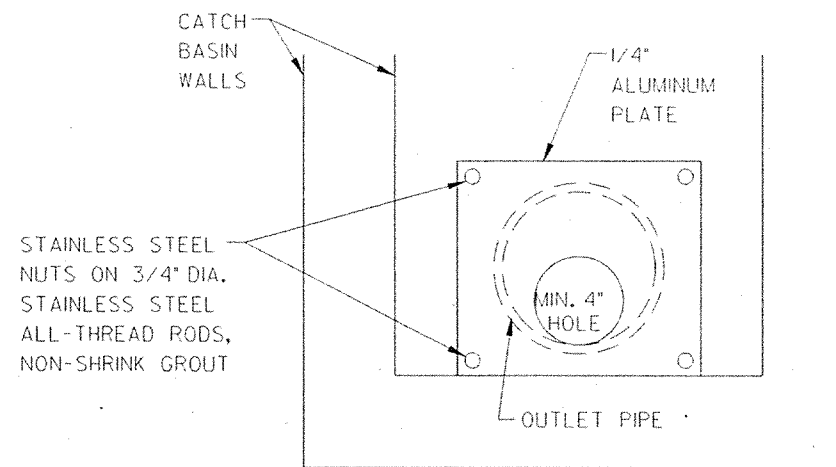

ELEVATION VIEW

CATCH BASIN

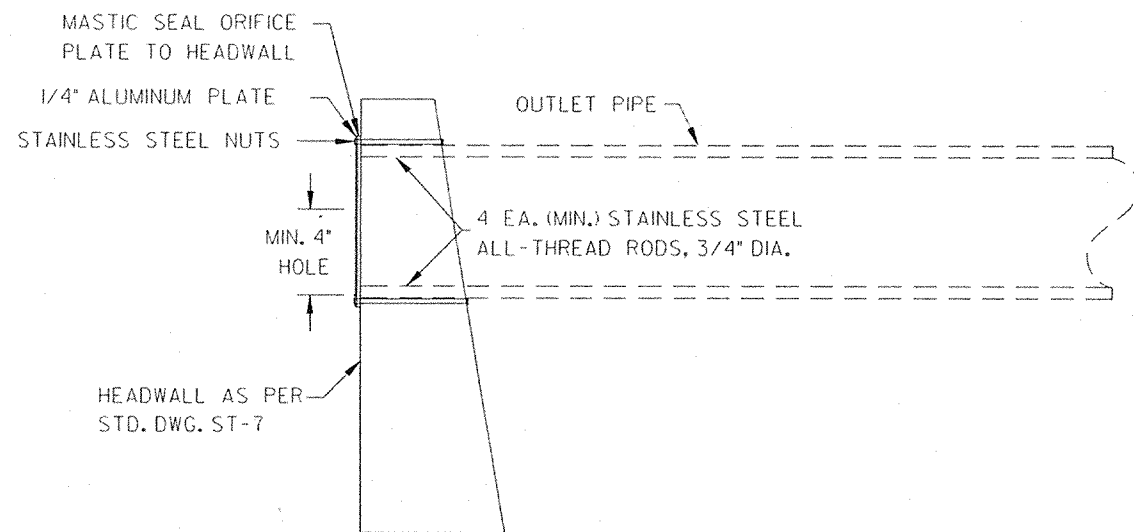

SIDE VIEW

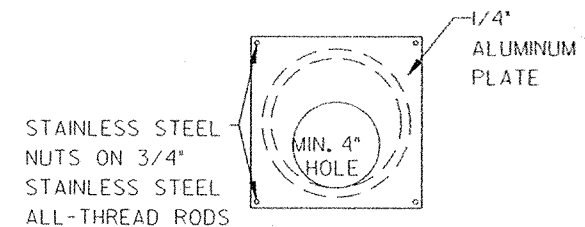

HEADWALL AS PER
STD. DWG. ST-7

ELEVATION VIEW

HEADWALL

8/10/2005 11:05:57 AM M:\CH2005-03 Development\Reps\CMS & STD\Drainage\ST-5.dgn

CITY OF HEATH
J. P. [Signature]
STREET SUPERINTENDENT

DATE
05-1997

STANDARD CONSTRUCTION DRAWING
ORIFICE DETAIL

NUMBER
ST-5

1 / 1

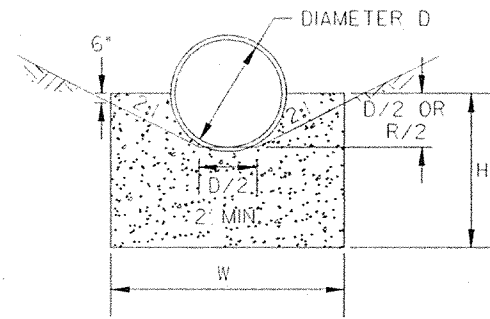

CIRCULAR

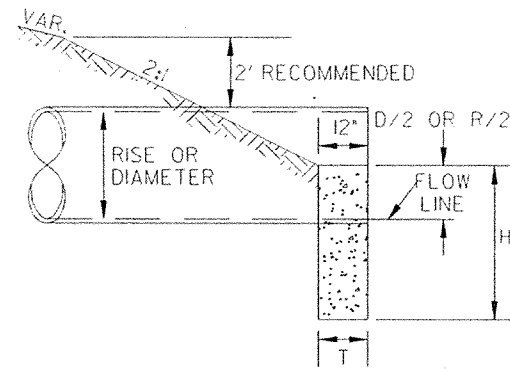

PROFILE

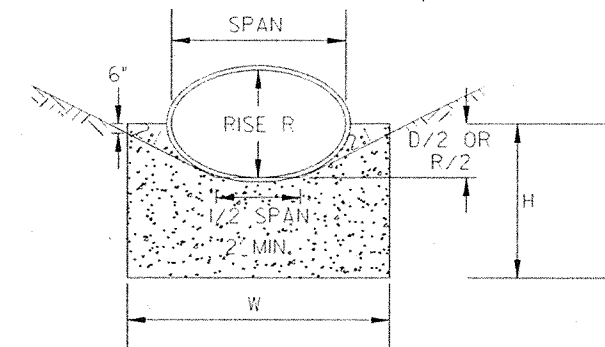

ELLIPTICAL

NOTES:
 I. CONCRETE FOR HEADWALLS SHALL BE CLASS "C"

ENDWALL FOR CONCRETE PIPE										
CIRCULAR					ELLIPTICAL					
D	W	H	T	C c.y.	SPAN	RISE	W	H	T	C c.y.
12"	2'-0"	3'-0"	12"	0.20	23"	14"	3'-0"	3'-2"	12"	0.29
15"	2'-6"	3'-2"	12"	0.25	30"	19"	3'-7"	3'-4"	12"	0.35
18"	3'-0"	3'-3"	12"	0.31	34"	22"	3'-11"	3'-5"	12"	0.38
21"	3'-6"	3'-4"	12"	0.37	38"	24"	4'-6"	3'-6"	12"	0.44
24"	4'-0"	3'-6"	12"	0.43	42"	27"	4'-8"	3'-7"	12"	0.45
27"	4'-6"	3'-8"	12"	0.49	45"	29"	5'-2"	3'-8"	12"	0.49
30"	5'-0"	3'-9"	12"	0.56	49"	32"	5'-5"	3'-10"	12"	0.52
33"	5'-6"	3'-10"	12"	0.62	53"	34"	5'-11"	4'-0"	14"	0.66
36"	6'-0"	4'-0"	12"	0.69	60"	38"	6'-10"	4'-2"	14"	0.82
39"	6'-6"	4'-2"	12"	0.77	68"	43"	8'-0"	4'-4"	16"	1.01
42"	7'-0"	4'-3"	12"	0.84	76"	48"	9'-2"	5'-0"	16"	1.34
48"	8'-0"	4'-6"	14"	1.09	83"	53"	10'-4"	5'-2"	18"	1.65
54"	9'-3"	4'-9"	14"	1.32	91"	58"	11'-6"	5'-5"	18"	1.97
60"	10'-6"	5'-6"	16"	1.93	98"	63"	12'-7"	5'-7"	20"	2.38
66"	11'-9"	5'-9"	18"	2.42	106"	68"	13'-9"	5'-10"	20"	2.69
72"	13'-0"	6'-0"	18"	2.77	113"	72"	14'-9"	6'-0"	22"	3.14
78"	14'-3"	6'-3"	20"	3.37	121"	77"	15'-11"	6'-3"	22"	3.49
84"	15'-6"	6'-6"	22"	4.05	128"	82"	17'-0"	6'-5"	24"	4.04
90"	16'-9"	6'-9"	22"	4.51	136"	87"	18'-2"	6'-8"	24"	4.84
96"	18'-0"	7'-0"	24"	5.31	143"	92"	19'-4"	6'-10"	26"	5.12
02"	19'-3"	7'-3"	26"	6.20	151"	97"	20'-6"	7'-1"	26"	5.42
08"	20'-6"	7'-6"	26"	6.78	166"	06"	22'-7"	7'-5"	28"	6.60
14"	21'-9"	7'-9"	28"	7.81	180"	16"	24'-10"	7'-10"	30"	7.99
20"	23'-0"	8'-0"	30"	8.93						
26"	24'-3"	8'-3"	30"	9.57						
32"	25'-6"	8'-6"	32"	0.84						
44"	28'-0"	9'-0"	34"	3.00						

8/10/2005 11:06:16 AM - M:\CH2005-03 Development\Reqs\CMS & STD\Drawings\ST-6.dgn - shiners

CITY OF HEATH
 STREET SUPERINTENDENT

DATE
 05-1997

STANDARD CONSTRUCTION DRAWING
 ENDWALL

NUMBER
 ST-6

1 / 1

8/10/2005 11:06:40 AM M:\CH2005-03 Development\Reps\CMS & STD\Drainage\ST-7.dgn

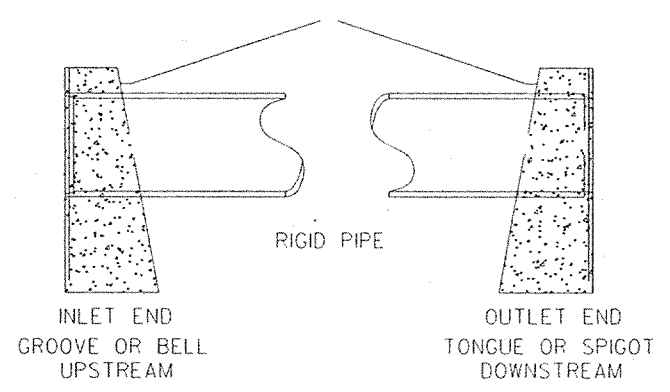
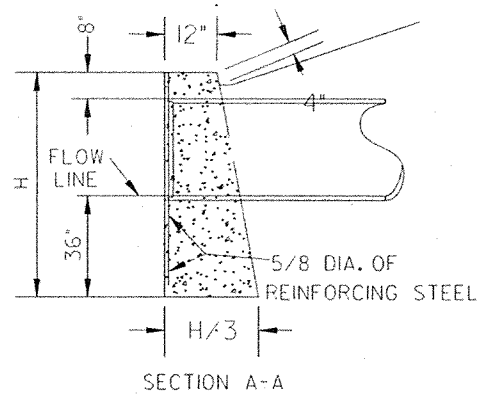
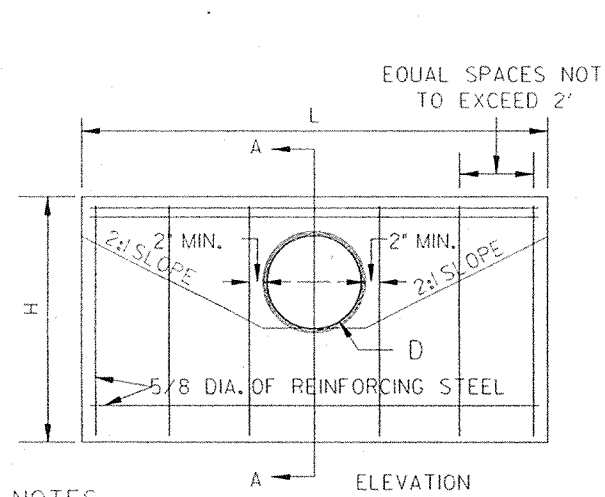

- NOTES:**
- HEADWALL WHERE REQUIRED WILL BE PROVIDED FOR NONSKEWED CULVERTS HAVING A DIAMETER OR RISE OF 36" OR LESS.
 - CONCRETE SHALL BE CLASS "C".
 - REINFORCING STEEL BARS SHALL BE 5/8" ROUND.
 - DIMENSIONS AND QUANTITIES ARE SHOWN FOR CIRCULAR SECTIONS ONLY. IT WILL BE NECESSARY TO DETERMINE DIMENSIONS FOR THE HEADWALL REQUIRED FOR REINFORCED ELLIPTICAL CONCRETE PIPE OR CORRUGATED METAL PIPE ARCHES IN ACCORDANCE WITH THE EQUATIONS LISTED ON THIS DRAWING.
 - CHAMFER ALL EXPOSED CORNERS 3/4 OF AN INCH ROUND.
 - FOUNDATION, WHERE THE SOIL BORINGS INDICATE A BEARING CAPACITY OF LESS THAN 2600 POUNDS PER SQUARE FOOT, IT WILL BE NECESSARY TO INCREASE THE WIDTH OF THE BASE.

DIMENSIONS			QUANTITIES ONE HEADWALL	
DIAMETER	H	L	CONCRETE CU. - YDS.	REINFORCING STEEL LBS.
15"	5'-2"	7'-0"	1.7	41
18"	5'-5"	8'-4"	2.2	57
21"	5'-8"	9'-8"	2.8	62
24"	5'-11"	11'-0"	3.3	69
30"	6'-5"	13'-8"	4.7	92
36"	7'-0"	16'-4"	6.5	105

L CIRCULAR SECTIONS = $5D + 4T$
 L ELLIPTICAL OR PIPE-ARCH = $4R + 4T$
 H CIRCULAR SECTIONS = $D + T + 44"$
 H ELLIPTICAL OR PIPE-ARCH = $R + T + 44"$
 D = DIAMETER OF PIPE
 R = RISK OF PIPE
 S = SPAN OF PIPE
 T = THICKNESS OF BARREL
 L = LENGTH OF HEADWALL
 H = HEIGHT OF HEADWALL

CITY OF HEATH
STREET SUPERINTENDENT

DATE
05-1997

STANDARD CONSTRUCTION DRAWING
HEADWALL

NUMBER
ST-7

1 / 1

3/15/2005 1:42:10 PM avanostan - i:\eng\Standard Drawings\Heath\03-05\Storm\dn\ST-8_3-05.dgn

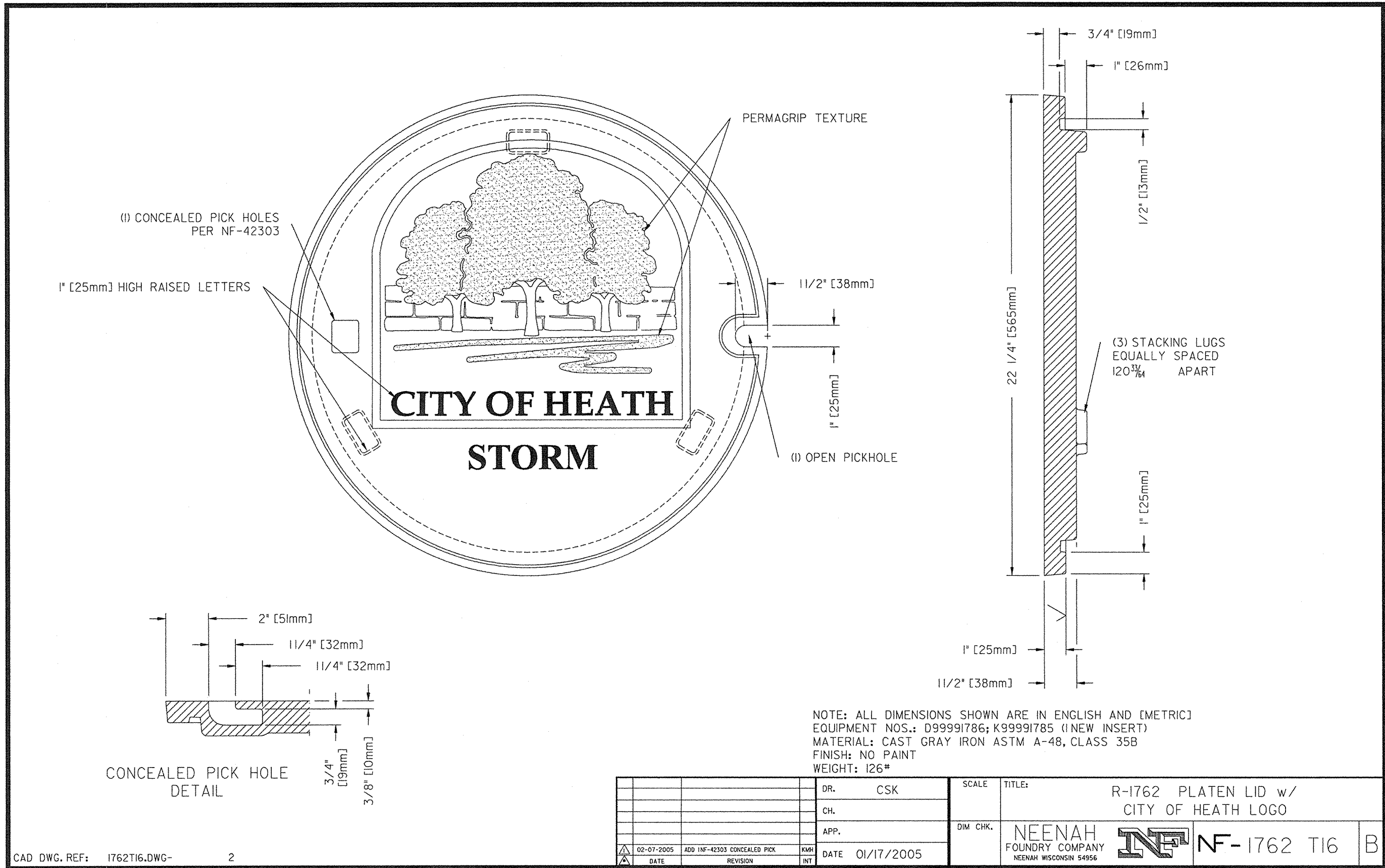

NOTE: ALL DIMENSIONS SHOWN ARE IN ENGLISH AND [METRIC]
 EQUIPMENT NOS.: D99991786; K99991785 (IN NEW INSERT)
 MATERIAL: CAST GRAY IRON ASTM A-48, CLASS 35B
 FINISH: NO PAINT
 WEIGHT: 126#

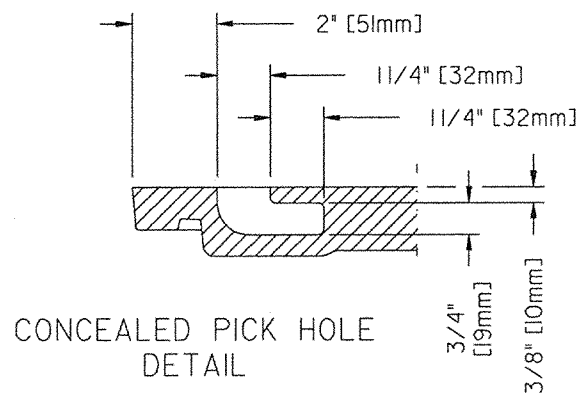

DR.	CSK	SCALE	TITLE: R-1762 PLATEN LID w/ CITY OF HEATH LOGO		
CH.		DIM CHK.	NEENAH FOUNDRY COMPANY NEENAH WISCONSIN 54956	NF	NF-1762 T16
APP.					
DATE	02-07-2005	ADD NF-42303 CONCEALED PICK	DATE	01/17/2005	
REVISION			INT		

CAD DWG. REF: 1762T16.DWG- 2

CITY OF HEATH
 STREET SUPERINTENDENT
 DATE 03-2005
 STANDARD CONSTRUCTION DRAWING
 STANDARD MANHOLE COVER (PUBLIC STORM SEWER)
 NUMBER ST-8

500 - SANITARY SEWER

ALL SANITARY SEWER PIPE, MANHOLES, FITTINGS, METHODS OF CONSTRUCTION, AND WORKMANSHIP FOR SANITARY SEWER AND APPURTENANCES SHOWN ON THESE PLANS SHALL CONFORM TO THE RULES AND REGULATIONS OF THE CITY OF HEATH AND 2010 ODOT ITEMS 603 & 604, CURRENT ON THE DATE OF CONTRACT UNLESS THE REQUIREMENTS OF SUCH RULES AND REGULATIONS ARE UPGRADED BY THE FOLLOWING NOTES OR BY THE CONSTRUCTION DETAILS SET FORTH HEREIN.

NO PERSON SHALL UNCOVER, MAKE ANY CONNECTIONS WITH OR OPENINGS INTO, USE, ALTER OR DISTURB ANY PUBLIC SEWER OR APPURTENANCE THEREOF WITHOUT FIRST OBTAINING A WRITTEN PERMIT FROM THE DIVISION OF UTILITIES.

ALL WATER LINES SHALL BE INSTALLED WITH AT LEAST 10 FEET HORIZONTAL SEPARATION FROM SANITARY SEWER AND STORM SEWER LINES. WHENEVER A WATER LINE AND SEWER MUST CROSS, THE SEWER MAIN (STORM OR SANITARY) SHALL BE LAID SUCH THAT THE CROWN OF THE SEWER IS AT LEAST 18 INCHES BELOW THE INVERT OF THE WATER LINE MEASURED BETWEEN THE OUTSIDE PIPE WALLS. IN CASES WHERE THE REQUIRED SEPARATION CANNOT BE MAINTAINED, CLOSER INSTALLATION MAY BE PERMITTED ON A CASE-BY-CASE BASIS ONLY AFTER RECEIPT OF WRITTEN CONCURRENCE FROM THE OHIO EPA DIVISION OF DRINKING WATER. 2003 RECOMMENDED STANDARDS FOR WATER WORKS, SECTIONS 8.8.2 AND 8.8.3 SHALL GOVERN AS TO THE SEPARATION OF WATER LINE FROM CONTAMINATION SOURCES.

PAYMENT FOR ALL OPERATIONS DESCRIBED ABOVE SHALL BE INCLUDED IN THE UNIT PRICE BID FOR THE PERTINENT 603 OR 604 ITEMS.

MATERIALS

ALL SANITARY SEWERS SHALL BE INSTALLED IN STRICT ACCORDANCE WITH THE MANUFACTURERS RECOMMENDATIONS AND ODOT ITEM 603, TYPE B OR C CONDUIT.

ALL SANITARY SEWER SHALL BE PVC PIPE. FOR SIZES UP TO 15 INCHES IN DIAMETER, PIPE SHALL CONFORM TO ASTM D-3034, SDR 35 WITH A CELL CLASSIFICATION OF ASTM B OR C 12454. FOR SIZES 18 INCHES AND LARGER, THE PVC PIPE SHALL CONFORM TO ASTM F 679 OR ASTM F 794 WITH A CELL CLASSIFICATION OF ASTM B OR C 12454.

FOR SIZES UP TO 15 INCH DIAMETER, PVC PIPE FITTINGS SHALL CONFORM, TO SDR 26 GASKETED HEAVY WALL SEWER FITTINGS MEETING ASTM D 3034 AND ASTM F 1336 WITH A CELL CLASSIFICATION OF ASTM B OR C 12454. FOR SIZES 18 INCHES AND LARGER, PVC PIPE FITTINGS SHALL CONFORM TO SDR 26 GASKETED SEWER FITTINGS MEETING ASTM F 679 AND ASTM F 1336.

FORCE MAIN SHALL BE PVC AWWA C-900 (DR-18) WITH A CELL CLASSIFICATION AS DEFINED IN ASTM D 1784 OR 12454 B OR C. FITTINGS SHALL BE DUCTILE IRON CONFORMING TO EITHER ANSI/AWWA C110/A21.10 OR ANSI/AWWA C153/A21.53. FITTINGS SHALL HAVE A STANDARD ASPHALTIC COATING ON THE EXTERIOR.

SERVICE CONNECTIONS SHALL CONSIST OF PVC PIPE (ASTM D-3034, SDR 35, 707.45) OF A SIZE NOT LESS THAN SIX (6) INCHES NOMINAL DIAMETER AND SHALL BE BUILT TO AVOID INTERFERENCE WITH PROPOSED UTILITIES WHEN CONNECTING TO THE SANITARY SERVICE.

MATERIALS CONTINUED

ALL FORCEMAIN INSTALLED SHALL HAVE UNDERGROUND LOCATING TAPE (GREEN) INSTALLED 2 FEET ABOVE THE UTILITY PIPE. LOCATING TAPE SHALL HAVE 18 INCHES OF COVER. ALL FORCEMAIN PIPE SHALL REQUIRE COPPERHEAD INDUSTRIES, LLC, COPPERHEAD HIGH STRENGTH REINFORCED TRACE WIRE, OR APPROVED EQUAL, INTENDED FOR DIRECT BURY, COLOR CODED PER AWWA STANDARD FOR THE SANITARY PIPE BEING MARKED, CAPABLE OF DETECTION BY A LOCATOR. TRACE WIRE SHALL BE INSTALLED ON THE BOTTOM HALF OF THE PIPE BELOW THE SPRING LINE. THE TRACE WIRE SHALL BE FASTENED TO THE PIPE WITH DUCT TAPE OR PLASTIC TIES AT 5' INTERVALS.

ALL TRACE WIRE AND TRACE WIRE PRODUCTS SHALL BE DOMESTICALLY MANUFACTURED IN THE U.S.A.

TRACE WIRE:
OPEN TRENCH - TRACE WIRE SHALL BE COPPERHEAD INDUSTRIES, LLC, 1230-HS, OR APPROVED EQUAL.

DIRECTIONAL DRILLING/BORING - TRACE WIRE SHALL BE COPPERHEAD INDUSTRIES, LLC, 1245-EHS, OR APPROVED EQUAL.

TRACE WIRE - PIPE BURSTING/SLIP LINING - TRACE WIRE SHALL BE COPPERHEAD INDUSTRIES, LLC, PBX-50, OR APPROVED EQUAL.

INSTALLATION:
TRACE WIRE INSTALLATION SHALL BE PERFORMED IN SUCH A MANNER THAT ALLOWS PROPER ACCESS FOR CONNECTION OF LINE TRACING EQUIPMENT, PROPER LOCATING OF WIRE WITHOUT LOSS OR DETERIORATION OF LOW FREQUENCY (512 HZ) SIGNAL FOR DISTANCES IN EXCESS OF 1,000 LINEAR FEET, AND WITHOUT DISTORTION OF SIGNAL CAUSED BY MULTIPLE WIRES BEING INSTALLED IN CLOSE PROXIMITY TO ONE ANOTHER.

IN ALL CASES THE DISTANCE BETWEEN ANODE RODS/ACCESS BOXES SHALL NOT EXCEED 1,000 LINEAR FEET.

TRACE WIRE SYSTEMS MUST BE INSTALLED AS A SINGLE CONTINUOUS WIRE, EXCEPT WHERE USING APPROVED CONNECTORS. NO LOOPING OR COILING OF WIRE IS ALLOWED.

ANY DAMAGE OCCURRING DURING INSTALLATION OF THE TRACE WIRE MUST BE IMMEDIATELY REPAIRED BY REMOVING THE DAMAGED WIRE, AND INSTALLING A NEW SECTION OF WIRE WITH APPROVED CONNECTORS. TAPING AND/OR SPRAY COATING SHALL NOT BE ALLOWED.

TRACE WIRE SHALL BE INSTALLED AT THE BOTTOM HALF OF THE PIPE AND SECURED (TAPED/TIED) AT 5' INTERVALS.

TRACE WIRE MUST BE PROPERLY GROUNDED AS SPECIFIED.

IN OCCURRENCES WHERE AN EXISTING TRACE WIRE IS ENCOUNTERED ON AN EXISTING UTILITY THAT IS BEING EXTENDED OR TIED INTO, THE NEW TRACE WIRE AND EXISTING TRACE WIRE SHALL BE CONNECTED USING APPROVED CONNECTORS, AND SHALL BE PROPERLY GROUNDED AT THE LOCATION AS SPECIFIED.

MATERIALS CONTINUED

CONNECTORS:
ALL MAINLINE TRACE WIRES MUST BE INTERCONNECTED IN INTERSECTIONS, AT MAINLINE TEES AND MAINLINE CROSSES. AT TEES, THE THREE WIRES SHALL BE JOINED USING A SINGLE CONNECTOR. AT CROSSES THE FOUR WIRES SHALL BE JOINED USING A SINGLE CONNECTOR. USE OF TWO CONNECTORS WITH A SHORT JUMPER WIRE BETWEEN THEM IS AN ACCEPTABLE ALTERNATIVE.

DIRECT BURY WIRE CONNECTORS - CONNECTORS SHALL BE COPPERHEAD INDUSTRIES, LLC, DRYCONN 3-WAY DIRECT BURY LUG, 3WB-01, OR APPROVED EQUAL, TO SEAL OUT MOISTURE AND CORROSION, AND SHALL BE INSTALLED IN A MANNER SO AS TO PREVENT ANY UNINSULATED WIRE EXPOSURE.

NON-LOCKING FRICTION FIT, TWIST ON OR TAPED CONNECTORS ARE PROHIBITED.

WRAPPING OF TRACE WIRE AT TREES/HYDRANTS IS PROHIBITED. CONNECTORS SHALL BE INSTALLED.

TERMINATION/ACCESS:
ALL TRACE WIRE TERMINATION POINTS MUST UTILIZE COPPERHEAD INDUSTRIES, LLC, RB14 TB, OR APPROVED EQUAL, ABOVE GROUND OR GRADE LEVEL/IN-GROUND, AS APPLICABLE, SPECIFICALLY MANUFACTURED FOR THIS PURPOSE.

ALL GRADE LEVEL/IN-GROUND ACCESS BOXES, SHALL BE APPROPRIATELY IDENTIFIED WITH "SANITARY" CAST INTO THE CAP AND BE COLOR CODED GREEN.

A MINIMUM 2 FT. OF EXCESS/SLACK WIRE IS REQUIRED IN ALL ACCESS BOXES AFTER MEETING FINAL ELEVATION.

ALL ACCESS BOXES MUST INCLUDE A MANUALLY INTERRUPTIBLE CONDUCTIVE LINK BETWEEN THE TERMINAL(S) FOR THE TRACE WIRE CONNECTION AND THE TERMINAL FOR THE GROUNDING ANODE WIRE CONNECTION.

GROUNDING ANODE WIRE SHALL BE CONNECTED TO THE IDENTIFIED (OR BOTTOM) TERMINAL ON ALL ACCESS BOXES.

GROUNDING:
GROUNDING OF TRACE WIRE SHALL BE ACHIEVED BY USE OF COPPERHEAD INDUSTRIES, LLC, ANO-1055, OR APPROVED EQUAL, WITH A MINIMUM OF 20 FEET OF #14 RED HDPE INSULATED COPPER CLAD STEEL WIRE CONNECTED TO ANODE (MINIMUM 0.5 LB.) SPECIFICALLY MANUFACTURED FOR THIS PURPOSE, AND BURIED AT THE SAME ELEVATION AS THE UTILITY.

WHEN GROUNDING THE TRACE WIRE IN AREAS WHERE THE TRACE WIRE IS CONTINUOUS AND NEITHER THE MAINLINE TRACE WIRE OR THE GROUNDING ANODE WIRE WILL BE TERMINATED AT/ABOVE GRADE, INSTALL GROUNDING ANODE DIRECTLY BENEATH AND IN-LINE WITH THE TRACE WIRE. DO NOT COIL EXCESS WIRE FROM GROUNDING ANODE. IN THIS INSTALLATION METHOD, THE GROUNDING ANODE WIRE SHALL BE TRIMMED TO AN APPROPRIATE LENGTH BEFORE CONNECTING TO TRACE WIRE WITH A MAINLINE TO LATERAL CONNECTOR.

WHERE THE ANODE WIRE WILL BE CONNECTED TO AN ACCESS BOX, A MINIMUM OF 2 FEET OF EXCESS/SLACK WIRE IS REQUIRED AFTER MEETING FINAL ELEVATION.

MATERIALS CONTINUED

SERVICE LATERALS:
A MAINLINE TRACE WIRE MUST BE INSTALLED, WITH ALL SERVICE LATERAL TRACE WIRES PROPERLY CONNECTED TO THE MAINLINE TRACE WIRE, TO ENSURE FULL TRACING/LOCATING CAPABILITIES FROM A SINGLE CONNECTION POINT.

LAY MAINLINE TRACE WIRE CONTINUOUSLY, BY-PASSING AROUND THE OUTSIDE OF MANHOLES/SERVICE LATERALS ON THE NORTH OR EAST SIDE.

TRACE WIRE ON ALL SANITARY SERVICE LATERALS MUST TERMINATE AT AN APPROVED ACCESS BOX COLOR CODED GREEN AND LOCATED DIRECTLY ABOVE THE SERVICE LATERAL AT THE EDGE OF THE ROAD RIGHT-OF-WAY.

ALL CONDUCTIVE AND NON-CONDUCTIVE SERVICE LINES SHALL INCLUDE TRACE WIRE.

SERVICE LATERALS ON PUBLIC PROPERTY:
TRACE WIRE MUST TERMINATE AT AN APPROVED GRADE LEVEL/IN-GROUND ACCESS BOX, LOCATED AT THE EDGE OF THE ROAD RIGHT-OF-WAY, AND OUT OF THE ROADWAY.

SERVICE LATERALS ON PRIVATE PROPERTY:
TRACE WIRE MUST TERMINATE AT AN APPROVED ABOVE GROUND ACCESS BOX, AFFIXED TO THE BUILDING EXTERIOR DIRECTLY ABOVE WHERE THE UTILITY ENTERS THE BUILDING, AT AN ELEVATION NOT GREATER THAN 5 VERTICAL FEET ABOVE THE FINISHED GRADE, OR TERMINATE AT AN APPROVED GRADE LEVEL/IN-GROUND ACCESS BOX, LOCATED 2 LINEAR FEET OF THE BUILDING BEING SERVED BY THE UTILITY.

LONG-RUNS, IN EXCESS OF 500 LINEAR FEET WITHOUT SERVICE LATERALS:
TRACE WIRE ACCESS MUST BE PROVIDED UTILIZING AN APPROVED GRADE LEVEL/IN-GROUND ACCESS BOX, LOCATED AT THE EDGE OF THE ROAD RIGHT-OF-WAY, AND OUT OF THE ROADWAY. THE GRADE LEVEL/IN-GROUND ACCESS BOX SHALL BE DELINEATED USING A MINIMUM 48" POLYETHYLENE MARKER POST, COLOR CODED PER AWWA STANDARD FOR THE SPECIFIC UTILITY.

TESTING:
ALL NEW TRACE WIRE INSTALLATIONS SHALL BE LOCATED USING TYPICAL LOW FREQUENCY (512HZ) LINE TRACING EQUIPMENT, WITNESSED BY THE CONTRACTOR, ENGINEER AND FACILITY OWNER AS APPLICABLE, PRIOR TO ACCEPTANCE OF OWNERSHIP.

THIS VERIFICATION SHALL BE PERFORMED UPON COMPLETION OF ROUGH GRADING AND AGAIN PRIOR TO FINAL ACCEPTANCE OF THE PROJECT.

CONTINUITY TESTING IN LIEU OF ACTUAL LINE TRACING SHALL NOT BE ACCEPTED.

CITY OF HEATH
Director of Utilities

DATE
10-2005
03-2015

STANDARD CONSTRUCTION DRAWING
SANITARY SPECIFICATIONS & NOTES

NUMBER
SA-0

1 / 2

DATE: _____ TIME: _____ USERNAME: _____ FILES

S01 - BACKFILL

ALL TRENCH BACKFILL SHALL BE COMPACTED BACKFILL AS PER ODOT ITEM 603.08. THE COST OF ALL COMPACTED BACKFILL SHALL BE INCLUDED IN THE PRICE BID FOR FURNISHING AND INSTALLING PIPE.

UNLESS STATED SPECIFICALLY IN THE CONSTRUCTION DRAWINGS, ALL CONDUIT SHALL BE INSTALLED AS TYPE C. THERE MAY BE AREAS ON THE PLANS WITH THE LIMITS INDICATED ON THE PROFILE VIEW OF THE SEWER AS "COMPACTED GRANULAR BACKFILL". WITHIN THESE LIMITS THE BACKFILL SHALL BE PER TYPE A & B, EXCEPT THE STRUCTURAL FILL SHALL EXTEND FROM THE TRENCH BOTTOM TO THE SUBGRADE.

S02 - SERVICE CONNECTIONS

SERVICES OR HOUSE CONNECTIONS SHALL NOT BE CONNECTED TO THE LATERAL OR MAIN LINE SEWERS SHOWN HEREON UNTIL FULL APPROVAL OF SAID LATERAL OR MAIN LINE SEWER HAS BEEN RECEIVED.

S03 - MANHOLE LOCATIONS

ALL SANITARY MANHOLES SHALL BE STAKED UNDER THE DIRECTION OF A REGISTERED SURVEYOR. THE STATION AND OFFSET OF THE MANHOLES SHOWN ON THE PLANS ARE TO THE CENTER OF THE MANHOLE BASE.

S04 - CONNECTION TO EXISTING PIPE

WHERE THE PLANS PROVIDE FOR PROPOSED CONDUIT TO BE CONNECTED TO, OR TO CROSS EITHER OVER OR UNDER AN EXISTING CONDUIT, IT SHALL BE THE RESPONSIBILITY OF THE CONTRACTOR TO LOCATE THE EXISTING CONDUIT BOTH AS TO LINE AND GRADE BEFORE HE STARTS TO LAY THE PROPOSED CONDUIT.

PAYMENT FOR ALL OPERATIONS DESCRIBED ABOVE SHALL BE INCLUDED IN THE ITEMS BID FOR FURNISHING AND INSTALLING PIPE.

S05 - CONNECTIONS TO EXISTING MANHOLES

WHERE NEW SEWERS ARE CONNECTED TO EXISTING MANHOLES, THE CONTRACTOR SHALL CORE DRILL ANY NEW OPENINGS INTO THE EXISTING MANHOLE. THE PIPE TO MANHOLE SHALL HAVE A WATER TIGHT JOINT OF A FLEXIBLE RUBBER GASKET EXPANSION BOOT. THE CONTRACTOR SHALL THEN CLEAN THE MANHOLE OF ALL DEBRIS BEFORE MAKING THE CONNECTION. THE CONTRACTOR SHALL CONSTRUCT A SEMI-CIRCULAR, CONCRETE CHANNEL TO THE NEW PIPE TO PROVIDE SMOOTH, UNINTERRUPTED FLOW THROUGH THE MANHOLE.

PAYMENT FOR THIS WORK SHALL BE INCLUDED IN THE ITEM BID FOR FURNISHING AND INSTALLING PIPE.

S06 - CONNECTIONS TO SANITARY SEWER SYSTEM

ROOF DRAINS, FOUNDATION DRAINS AND OTHER CLEAN WATER CONNECTIONS TO THE SANITARY SEWER SYSTEM ARE PROHIBITED IN THE CITY OF HEATH.

S07 - PROFILE

PROFILE IS SHOWN ALONG SEWER CENTERLINE. PROFILES ARE NOT SHOWN ON ALL INLET CONNECTOR SEWERS.

S08 - TOP OF CASTING ELEVATIONS

THE ELEVATIONS SHOWN ON THE PLANS FOR TOP OF CASTING OF PROPOSED MANHOLES MATCHES THE EXISTING OR PROPOSED PAVEMENT SURFACE. IN AREAS WHERE THE PAVEMENT IS TO BE RESURFACED THE TOP OF CASTING SHALL MATCH THE SURFACE OF THE RESURFACED PAVEMENT.

S09 - PLUGS

PLUGS, WHERE SHOWN ON THE PLANS OR ORDERED BY THE ENGINEERS, SHALL BE OF BRICK MASONRY, 8" IN THICKNESS FOR SEWERS OF 21" DIAMETER OR LARGER AND 4" IN THICKNESS FOR SEWERS SMALLER THAN 21" IN DIAMETER. THE EXTERIOR FACE OF THE PLUG SHALL BE PLASTERED WITH A 1/2" COAT OF MORTAR.

S10 - SEQUENCE OF OPERATIONS

THE CONTRACTOR SHALL CONDUCT HIS OPERATIONS IN SUCH A WAY THAT HE WILL COMPLETE ANY PORTION OF THE SEWER CONSTRUCTION STARTED, (INCLUDING MANHOLES, INLETS, CATCH BASINS, CONNECTIONS AND PLUGGING OF LINES) TO INSURE PROPER OPERATION AT ALL TIMES, BEGINNING AT THE OUTLET END OF ANY PIPE. ANY FAILURE OF THE CONTRACTOR TO COMPLY WITH THE ABOVE PROVISIONS WILL BE REASON FOR THE ENGINEER TO SUSPEND WORK UNTIL THE CONDITIONS ARE MET.

S11 - EXISTING SEWERS AND STRUCTURES

THE CONTRACTOR SHALL REPLACE TO THE SATISFACTION OF THE ENGINEER ALL EXISTING MANHOLES, CATCH BASINS, DRAINS, SEWERS AND APPURTENANCES REMOVED OR DAMAGED DURING CONSTRUCTION. THE ABOVE IS NOT APPLICABLE TO STRUCTURES TO BE ABANDONED. THE CONTRACTOR SHALL REMOVE DEBRIS, SILT, ETC. FROM EXISTING MANHOLES AND CATCH BASINS AND VARIOUS SEWER PIPE WHICH ARE CONNECTED IN THE NEW SYSTEM.

S12 - EXISTING SEWAGE FLOWS

THE CONTRACTOR SHALL MAKE PROVISIONS TO MAINTAIN FLOWS IN THE EXISTING SEWER AT ALL TIMES DURING CONSTRUCTION. METHODS FOR MAINTAINING FLOWS SHALL BE SUBMITTED TO THE ENGINEER FOR APPROVAL PRIOR TO CONSTRUCTION. AT NO TIME WILL SANITARY SEWAGE BE ALLOWED TO DISCHARGE TO ANY RIVER OR STREAM NOR SPILL OUT ON THE GROUND. APPROVAL OF PLANS BY THE ENGINEER TO MAINTAIN FLOWS SHALL NOT RELIEVE THE CONTRACTOR OF ANY RESPONSIBILITY TO ADEQUATELY PROVIDE FOR ALL FLOWS.

THE CONTRACTOR SHALL BE AWARE THAT THE EXISTING SEWERS MAY BE OPERATING UNDER PRESSURE (HEAD) DURING TIMES OF RAINFALL; THEREFORE THE CONTRACTOR SHALL EXERCISE CAUTION WHEN WORKING ON THESE SEWERS.

PAYMENT FOR THIS WORK SHALL BE INCLUDED IN THE ITEM BID FOR FURNISHING AND INSTALLING PIPE.

S13 - SANITARY SEWER-MANHOLE CONNECTIONS

THE SANITARY SEWER PIPE TO MANHOLE CONNECTIONS SHALL BE OF A FLEXIBLE WATERTIGHT JOINT OF APPROVED MANUFACTURE. THE JOINT MAY BE OF THE FOLLOWING DESIGN (A)RUBBER SLEEVE WITH STAINLESS STEEL BANDING, (B)RUBBER GASKET COMPRESSION, OR (C)RUBBER GASKET EXPANSION.

PAYMENT FOR THIS WORK AND MATERIALS SHALL BE INCLUDED WITH THE ITEM BID FOR FURNISHING AND INSTALLING MANHOLES.

S14 - SEWER-WATER MAIN CROSSING

WHERE THE WATER MAIN DOES NOT MAINTAIN 18" VERTICAL SEPARATION OR IS BELOW THE SANITARY SEWER, THE SANITARY SEWER SHOULD BE CONSTRUCTED (OR ENCASED IN) WATER MAIN TYPE MATERIALS WHICH WILL WITHSTAND A 50 PSI PRESSURE TEST FOR A DISTANCE OF 10 FEET ON BOTH SIDES OF THE WATER MAIN. AT ALL POINTS OF CROSSING OF WATER OR SEWER CONDUITS, THE BACKFILL SHALL BE GRANULAR MATERIAL BETWEEN THE TOP OF THE UPPER CONDUIT AND THE BOTTOM OF THE LOWER CONDUIT.

S15 - UNRECORDED SANITARY CONNECTIONS

ANY UNRECORDED ACTIVE CONNECTION TO A SANITARY SEWER ENCOUNTERED DURING CONSTRUCTION SHALL BE RECONNECTED TO THE EXISTING SEWER, AS DIRECTED BY THE ENGINEER. THE FOLLOWING ESTIMATED QUANTITIES HAVE BEEN INCLUDED IN THE GENERAL SUMMARY FOR THE WORK NOTED ABOVE:

ITEM 603 6" CONDUIT, TYPE B, ___L.F

S16 - Y-POLE INSTALLATION

AT EACH MANHOLE AND AT THE END OF THE SERVICE SHALL BE SET A Y-POLE MADE OF TIMBER NOT LESS THEN 3-INCH X 3-INCH IN SECTION WITH THE TIMBER BEING IN GOOD CONDITION, STRAIGHT, SOUND AND FREE FROM LARGE TO LOOSE KNOTS. THE Y-POLE SHALL EXTEND TO A POINT 4-FEET ABOVE THE BACKFILL. THE TOP 1-FOOT OF THE POST SHALL BE PAINTED GREEN ON ALL FOUR SIDES. THE Y-POLE SHALL BE BRACED IN SUCH A MANNER AS TO HOLD IT FIRMLY IN POSITION DURING BACKFILLING. IF THE Y-POLE IS PULLED OUT OR BENT OVER, THE CONTRACTOR SHALL DIG DOWN TO ITS END AND REPLACE OR STRAIGHTEN THE Y-POLE. THE Y-POLE SHALL BE ADJACENT TO THE END OF THE SERVICE OR MANHOLE, BUT NOT ON IT.

PAYMENT FOR THE FURNISHING AND PLACING OF THE Y-POLE, WILL BE INCLUDED IN THE UNIT PRICE FOR THE MANHOLE OR SERVICE LATERAL.

S17 - SANITARY SEWER LATERALS

ALL BACKFILL FOR SANITARY SEWER LATERALS UNDER THE EXISTING OR PROPOSED STREET PAVEMENT AND WITHIN THE INFLUENCE OF THE PAVEMENT SHALL BE COMPACTED GRANULAR MATERIAL. THE REMAINING BACKFILL WITHIN THE STREET RIGHT-OF-WAY SHALL BE COMPACTED BACKFILL PER ITEM 603, TYPE C.

PAYMENT FOR THIS WORK AND MATERIAL SHALL BE INCLUDED IN THE UNIT BID FOR FURNISHING AND INSTALLING THE CONDUIT.

S18 - SANITARY TESTING

ALL SANITARY SEWERS SHALL BE PRESSURE TESTED FOR INFILTRATION AND EXFILTRATION, HAVING MAXIMUM TEST SECTIONS OF 400 FEET. FOR THE EXFILTRATION TEST A MINIMUM OF 2 FEET OF POSITIVE HEAD SHALL BE MAINTAINED DURING THE TEST. A MAXIMUM 100 GAL/IN/MI/DAY IS PERMITTED.

CONTRACTOR SHALL MANDREL TEST ALL ABS OR PVC PIPE FOR DEFLECTION A MINIMUM OF 30 DAYS AFTER INSTALLATION. TESTING SHALL BE IN ACCORDANCE WITH ASTM D3034. THE MANDREL MUST BE AT LEAST 95% OF THE BASE INSIDE DIAMETER OF THE PIPE.

MANHOLES SHALL BE TESTED FOR LEAKS USING THE NEGATIVE AIR (VACUUM) METHOD. TESTING SHALL BE PERFORMED AS PER ASTM C1244.

ALL TESTING SHALL BE PERFORMED UNDER THE SUPERVISION OF A REGISTERED PROFESSIONAL ENGINEER OR A REPRESENTATIVE OF THE CITY OF HEATH. THE COST OF THE ABOVE WILL BE INCLUDED IN THE UNIT PRICE BID FOR THE SANITARY SEWER.

S19 ITEM 604 - SANITARY MANHOLE

SANITARY MANHOLES ARE TO BE IN ACCORDANCE WITH HEATH STANDARD DRAWING SA-1 AND SA-2.

PUBLIC SANITARY MANHOLE COVERS ARE TO BE THE HEATH CUSTOM LID PER STANDARD DRAWING SA-10. ALL PRIVATE SANITARY MANHOLES SHALL BE EMBOSSED "SANITARY SEWER." MANHOLES SHALL BE ADJUSTED TO GRADE USING PRECAST CONCRETE RINGS.

S20 - CONCRETE COLLAR

CONTRACTOR SHALL REFER TO HEATH STANDARD CONSTRUCTION DRAWINGS SA-1 AND SA-2 FOR CONCRETE COLLARS TO BE PLACED AROUND SANITARY MANHOLES.

CITY OF HEATH
DIRECTOR OF UTILITIES

DATE
10-2005
03-2015
10-2017
03-2022

STANDARD CONSTRUCTION DRAWING
SANITARY SPECIFICATIONS & NOTES

NUMBER
SA-0

SDATES - TIMES - SUSERNAME3 - FILES

8/10/2005 11:07:33 AM shaines M:\Ch2005-03 Development Regs\CVS & STD\Sewer\SA-3.dgn

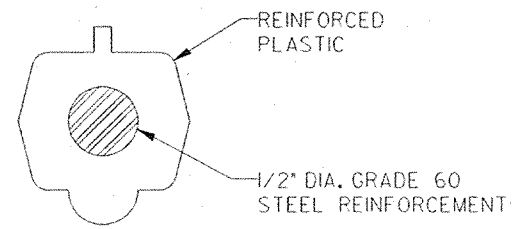

SECTION "A - A"

NOTES:

1. MATERIAL TO BE COPOLYMER POLYPROPYLENE PLASTIC OR APPROVED EQUAL.
2. MINIMUM O.S.H.A. REQUIREMENTS SHALL BE MET.
3. STEPS SHALL MEET THE REQUIREMENTS OF ASTM C-478 AND SHALL BE INSTALLED WITH A UNIFORM VERTICAL SPACING OF 12" TO 16".

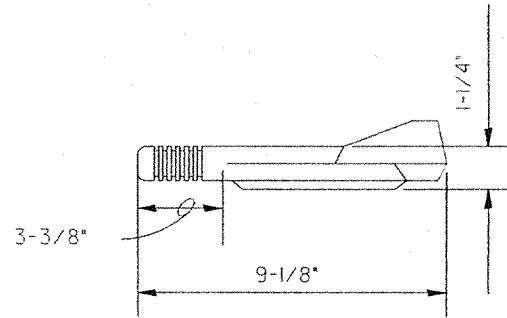
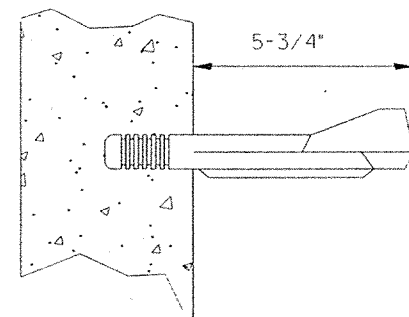
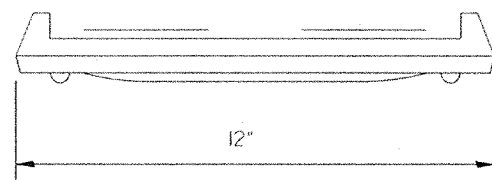
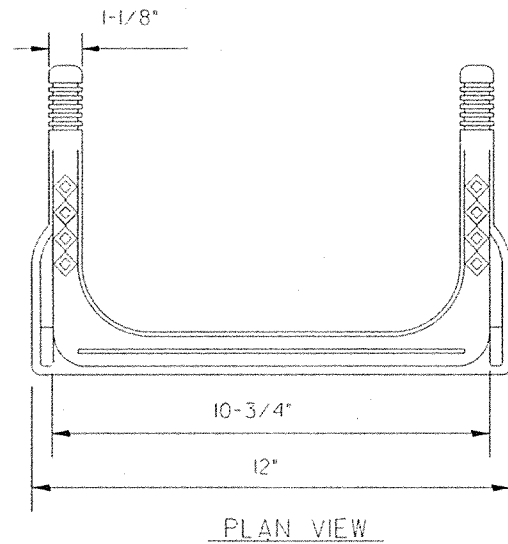

NUMBER
SA-3
1 / 1

STANDARD CONSTRUCTION DRAWING
MANHOLE STEP

DATE
05-1997

CITY OF HEATH
Olson
DIRECTOR OF UTILITIES

8/10/2005 11:07:48 AM straines M:\CH2005-03 Development\Reps\CMS & STD\Sewer\SA-4.dgn

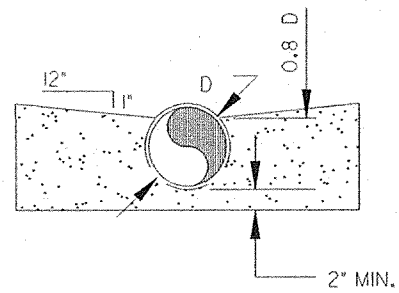

SECTION A-A

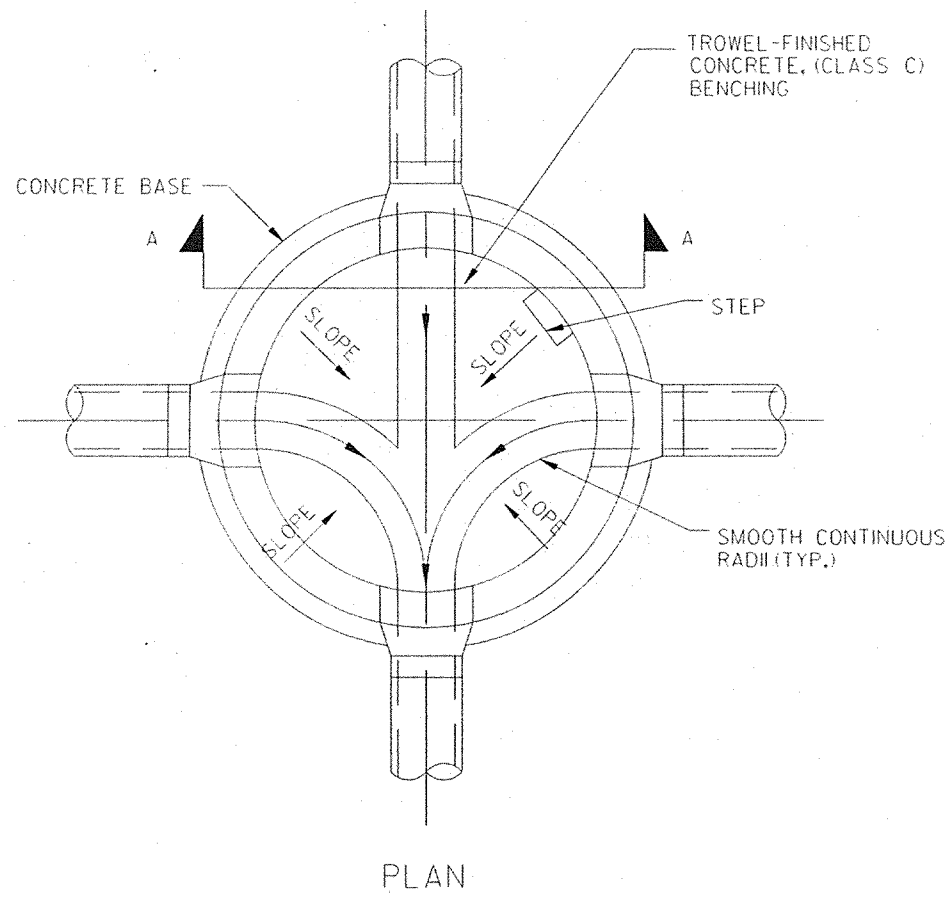

PLAN

NUMBER
SA-4

STANDARD CONSTRUCTION DRAWING
MANHOLE INVERT

DATE
05-1997

CITY OF HEATH
[Signature]
DIRECTOR OF UTILITIES

8/10/2005 11:08:05 AM M:\CH2005-03 Development Regs\CVS & STD\Sewer\SA-5.dgn

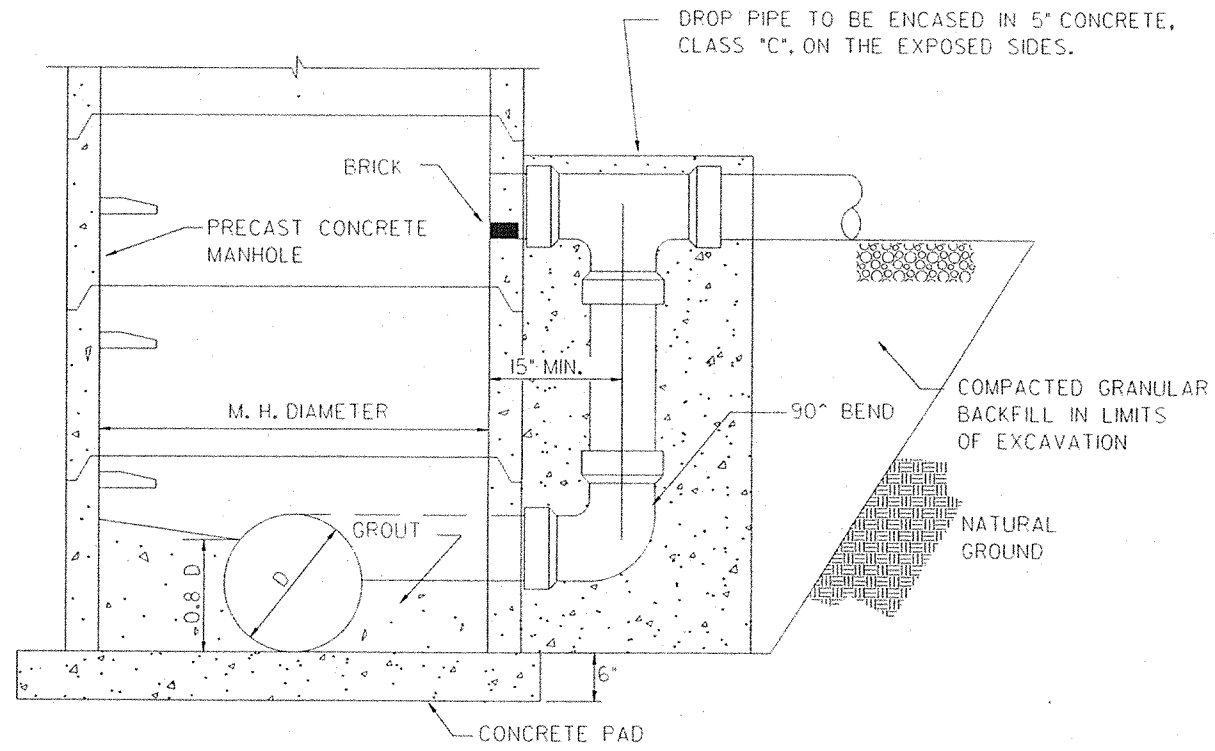

NOTES:

1. DIAMETER OF DROP PIPE TO BE EQUAL TO SEWER COMING INTO MANHOLE MORE THAN TWO FEET ABOVE MANHOLE INVERT.
2. OUTSIDE DROPS ARE REQUIRED FOR NEW CONSTRUCTION.

NUMBER
SA-5

STANDARD CONSTRUCTION DRAWING
OUTSIDE DROP FOR MANHOLE

DATE
05-1997

CITY OF HEATH
Oliver
DIRECTOR OF UTILITIES

8/10/2005 11:08:23 AM shaines M:\City2005-03 Development\Regs\CWS & STD\Sewer\SA-6.dgn

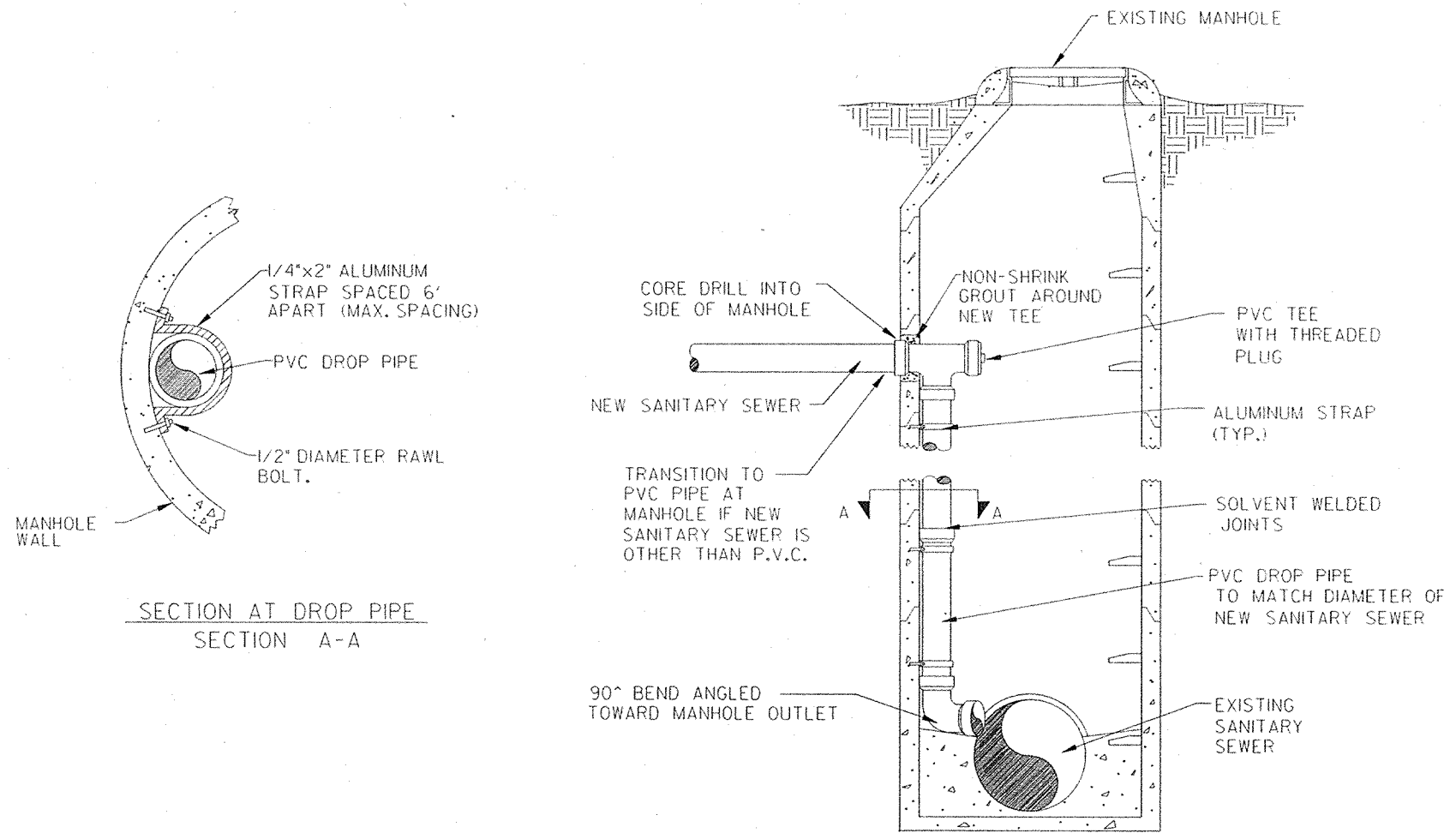

SECTION AT DROP PIPE
SECTION A-A

NUMBER
SA-6
1 1

STANDARD CONSTRUCTION DRAWING
INSIDE DROP FOR EXISTING MANHOLES

DATE
05-1997

CITY OF HEATH
Robert
DIRECTOR OF UTILITIES

8/10/2005 11:08:39 AM M:\CH2005-03 Development Revs\CMS & STD\Sewer\SA-7.dgn

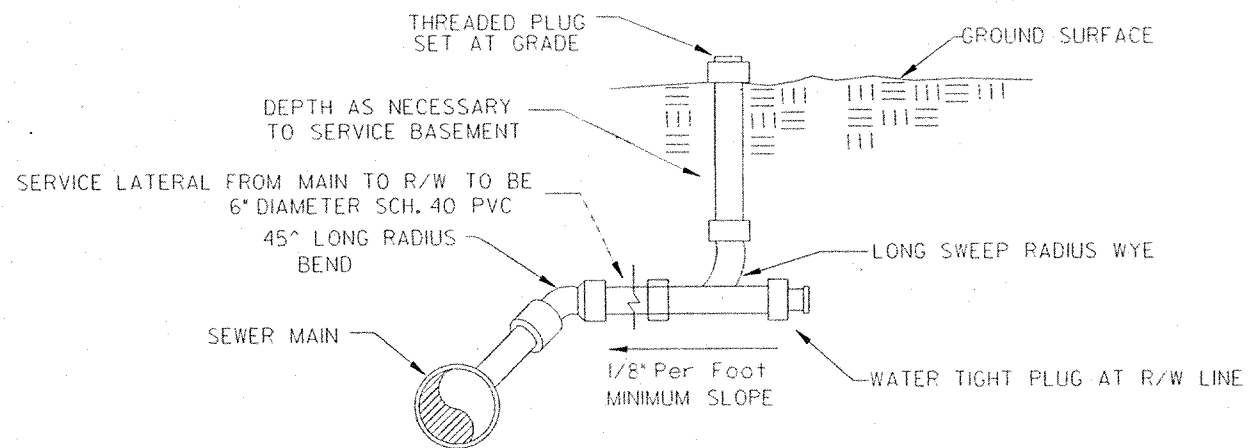

SECTION

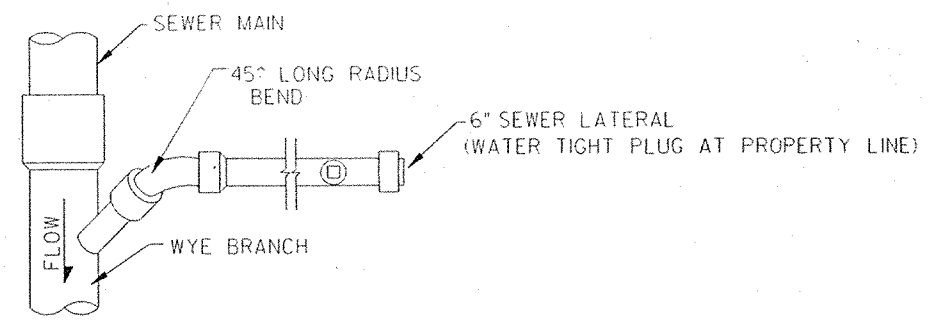

PLAN

NOTES:

1. SERVICES SHALL BE BUILT TO A LOCATION SHOWN ON PLANS.
2. WYE POLES (2" PVC PIPE OR APPROVED EQUAL) SHALL BE PLACED BY THE CONTRACTOR AT THE PLUG FOR FUTURE LOCATION AND EXTENSION.
3. THE CURB SHALL BE STAMPED WITH AN "S" WHERE THE SERVICE ENTERS THE PROPERTY.
4. TRENCHES SHALL BE BACKFILLED WITH GRANULAR MATERIAL TO A POINT 6" ABOVE THE TOP OF PIPE.
5. ALLOWABLE CONNECTIONS TO THE SERVICE WITH THE 4" DIAMETER WASTE LINE INCLUDE: BORE DONUTS, FLEXIBLE COUPLINGS, AND FLEXIBLE REDUCING COUPLING. COUPLING CLAMPS SHALL BE STAINLESS STEEL.
6. CLEANOUTS SHALL BE PLACED EITHER 0.5' INSIDE THE RIGHT-OF-WAY OR 5' OUTSIDE THE BUILDING SERVED.
7. LATERALS SHALL EXTEND TO R/W LINE OR INSIDE LIMIT OF UTILITY EASEMENT.

CITY OF HEATH
Baron
DIRECTOR OF UTILITIES

DATE
05-1997

STANDARD CONSTRUCTION DRAWING
SERVICE LATERAL

NUMBER
SA-7

1 / 1

8/10/2005 11:08:54 AM shromes M:\City2005-03 Development\Reqs\CMS & STD\Sewer\SA-8.dgn

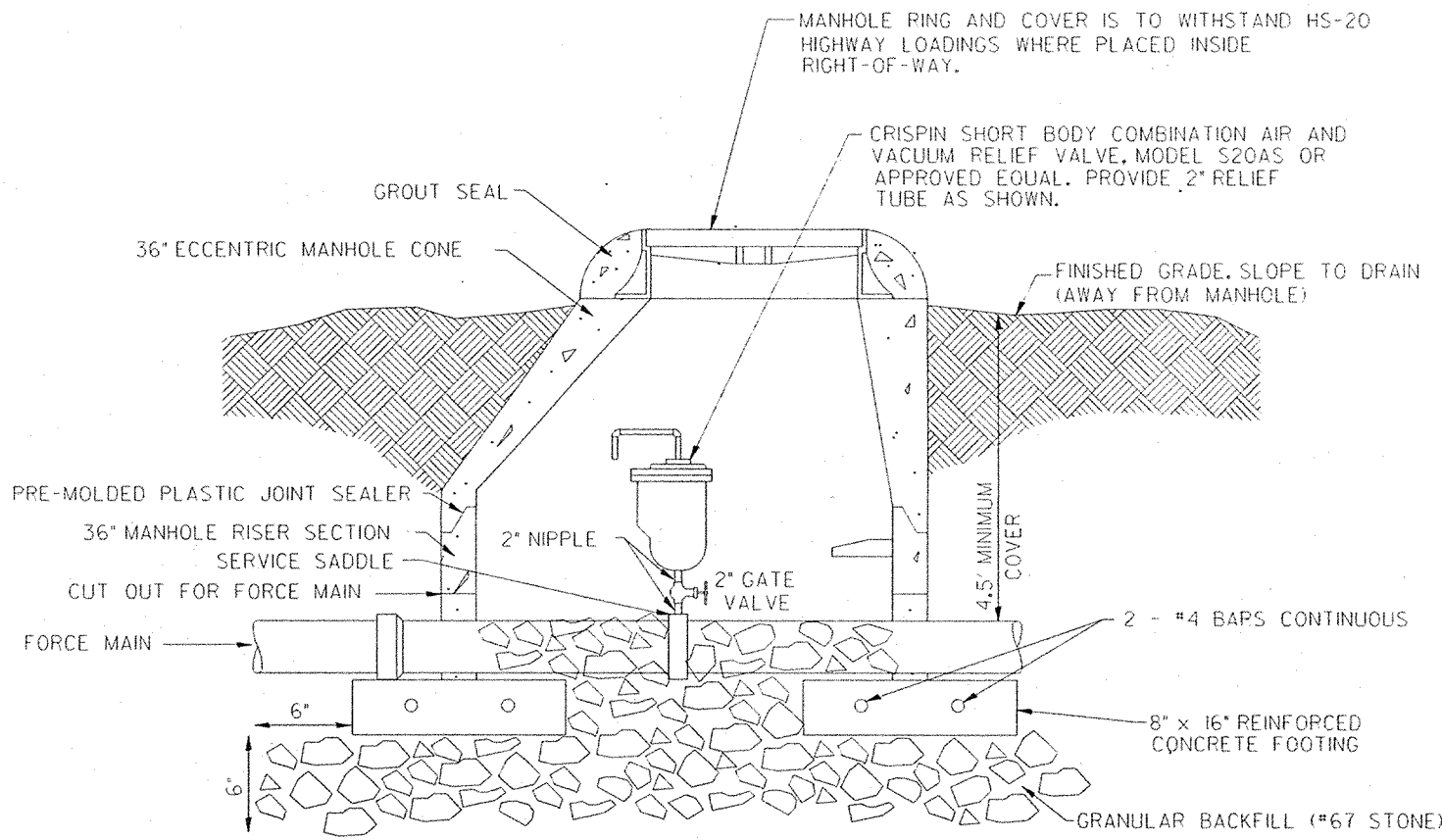

NOTE: AIR RELEASE VALVE IS TO BE PLACED AT THE HIGH POINT IN THE FORCE MAIN,
OR AS LOCATED BY THE DESIGN ENGINEER.

MANHOLE RING AND COVER IS TO WITHSTAND HS-20 HIGHWAY LOADINGS WHERE PLACED INSIDE RIGHT-OF-WAY.

CRISPIN SHORT BODY COMBINATION AIR AND VACUUM RELIEF VALVE, MODEL S20AS OR APPROVED EQUAL. PROVIDE 2" RELIEF TUBE AS SHOWN.

GROUT SEAL
36" ECCENTRIC MANHOLE CONE

FINISHED GRADE. SLOPE TO DRAIN (AWAY FROM MANHOLE)

PRE-MOLDED PLASTIC JOINT SEALER
36" MANHOLE RISER SECTION
SERVICE SADDLE
CUT OUT FOR FORCE MAIN

2" NIPPLE
2" GATE VALVE

4.5" MINIMUM COVER

2 - #4 BARS CONTINUOUS

FORCE MAIN

8" x 16" REINFORCED CONCRETE FOOTING

GRANULAR BACKFILL (#67 STONE)

CITY OF HEATH
Robert Brown
DIRECTOR OF UTILITIES

DATE
05-1997

STANDARD CONSTRUCTION DRAWING
FORCE MAIN AIR RELEASE VALVE

NUMBER
SA-8

1 / 1

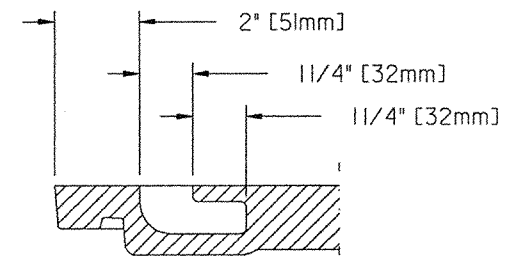
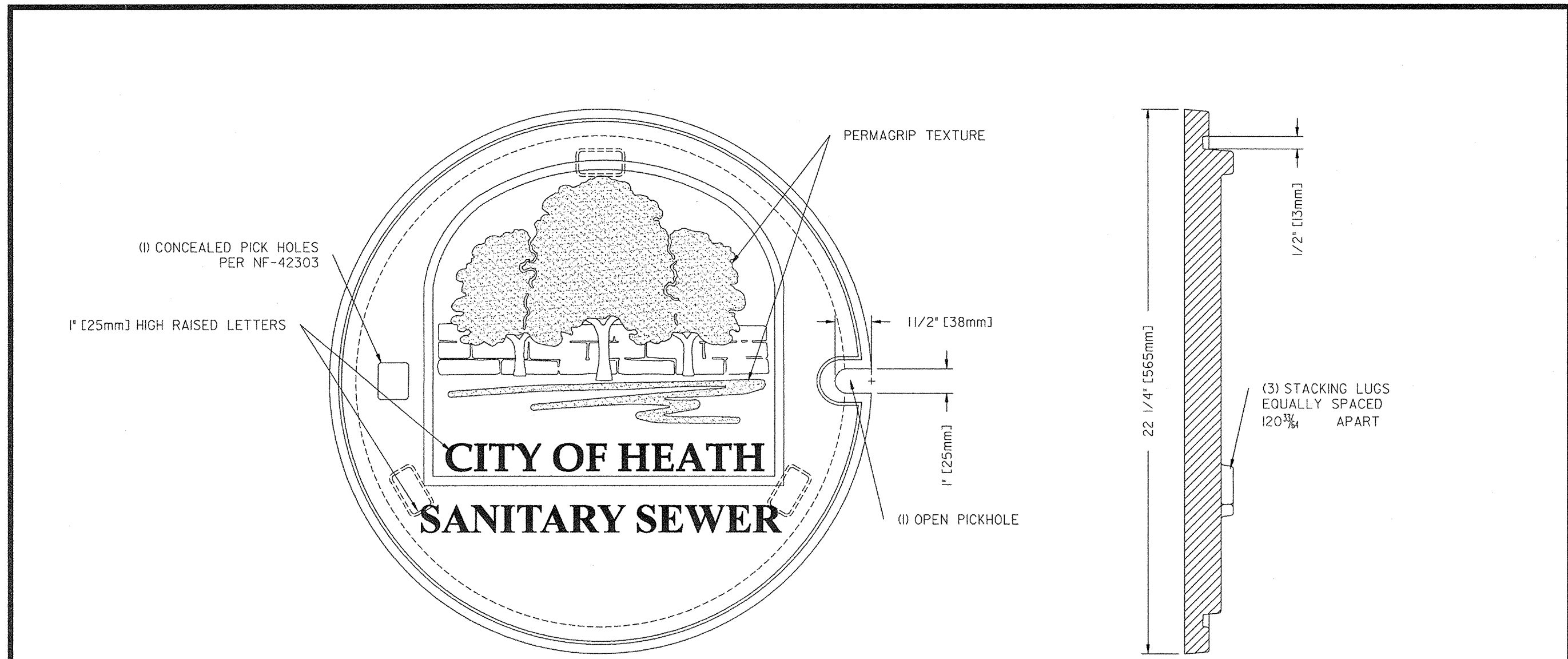

CONCEALED PICK HOLE
 DETAIL

NOTE: ALL DIMENSIONS SHOWN ARE IN ENGLISH AND [METRIC]
 EQUIPMENT NOS.: D99991786; K99991785 (I NEW INSERT)
 MATERIAL: CAST GRAY IRON ASTM A-48, CLASS 35B
 FINISH: NO PAINT
 WEIGHT: 126#

CAD DWG. REF: 1762T16.DWG- 2

DR.	CSK	SCALE	TITLE:	R-1762 PLATEN LID w/ CITY OF HEATH LOGO
CH.				
APP.		DIM CHK.	NEENAH FOUNDRY COMPANY NEENAH WISCONSIN 54956	NEE NF-1762 T16
DATE	02-07-2005	DATE	01/17/2005	B
	ADD 1NF-42303 CONCEALED PICK			
	REVISION			

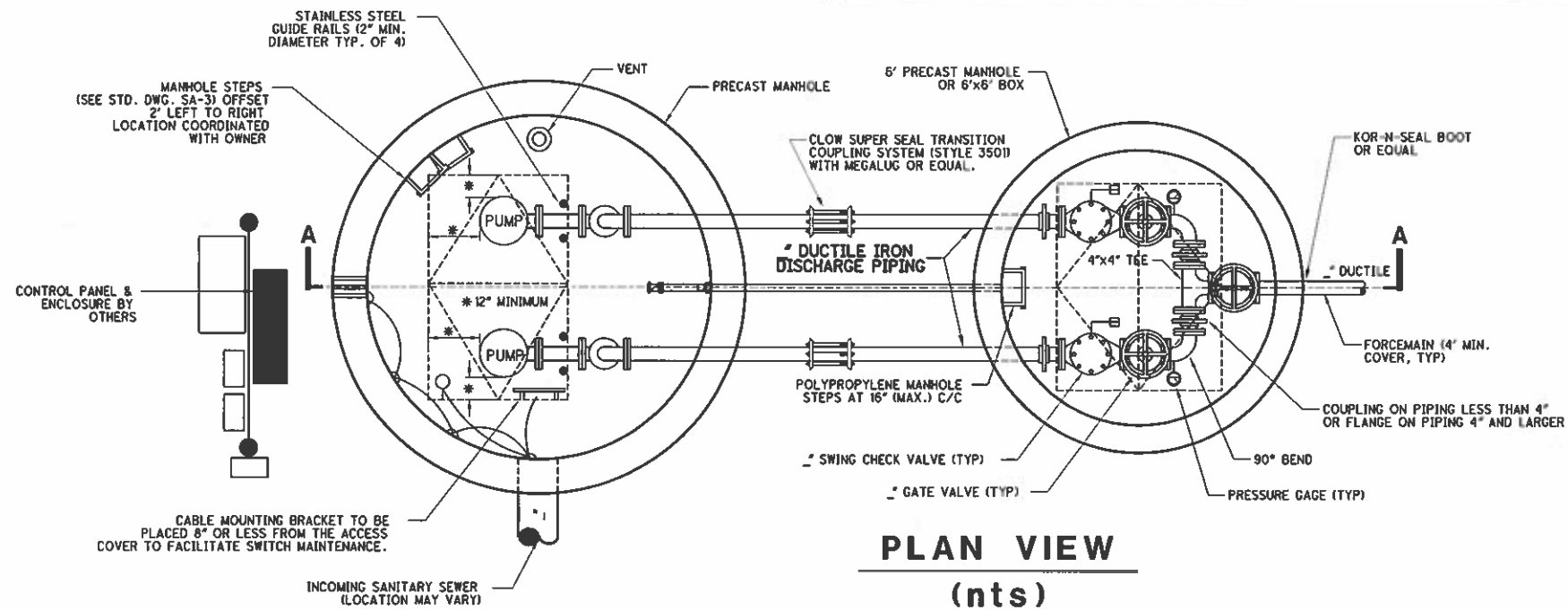

PUMPS SHALL BE (EXPLOSION PROOF):

MANUFACTURER: FLYGT MODEL: _____ ; IMP. DIA.: _____

SPEED: _____ RPM ; DISCHARGE SIZE: _____ IN. ; VOLTAGE: _____

HZ.: _____ ; PHASE: _____ ; HP.: _____

MIN. SOLID SIZE: IN. ; CURVE: _____

OPERATING CONDITIONS SHALL BE _____ GPM AT _____ FEET TDH.

THE CONTRACTOR SHALL DELIVER A SPARE PUMP TO THE CITY OF HEATH.

LOCATION	ELEVATION	DESCRIPTION
ELEV T	---	TOP SLAB ELEVATIONS
ELEV U	---	INVERT IN (GRAVITY FLOW)
ELEV V	---	HIGH LEVEL ALARM & LAG PUMP ON
ELEV X	---	LEAD PUMP ON
ELEV Y	---	PUMP OFF
ELEV Z	---	BOTTOM OF WET WELL

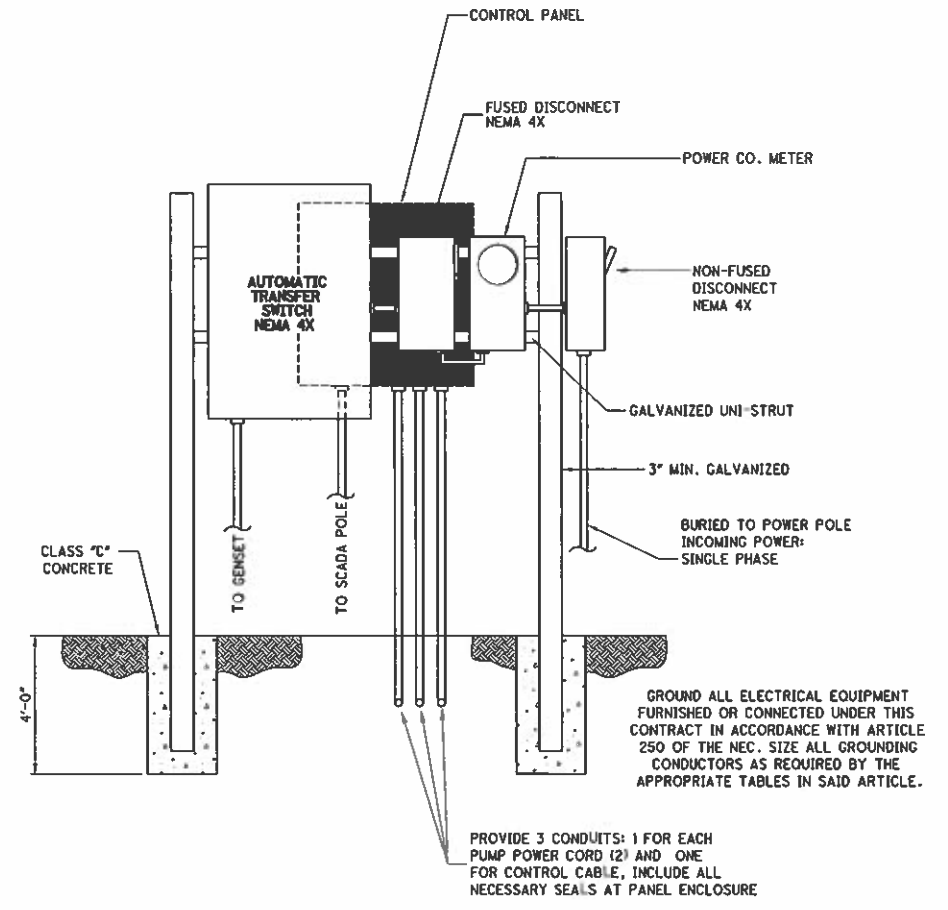
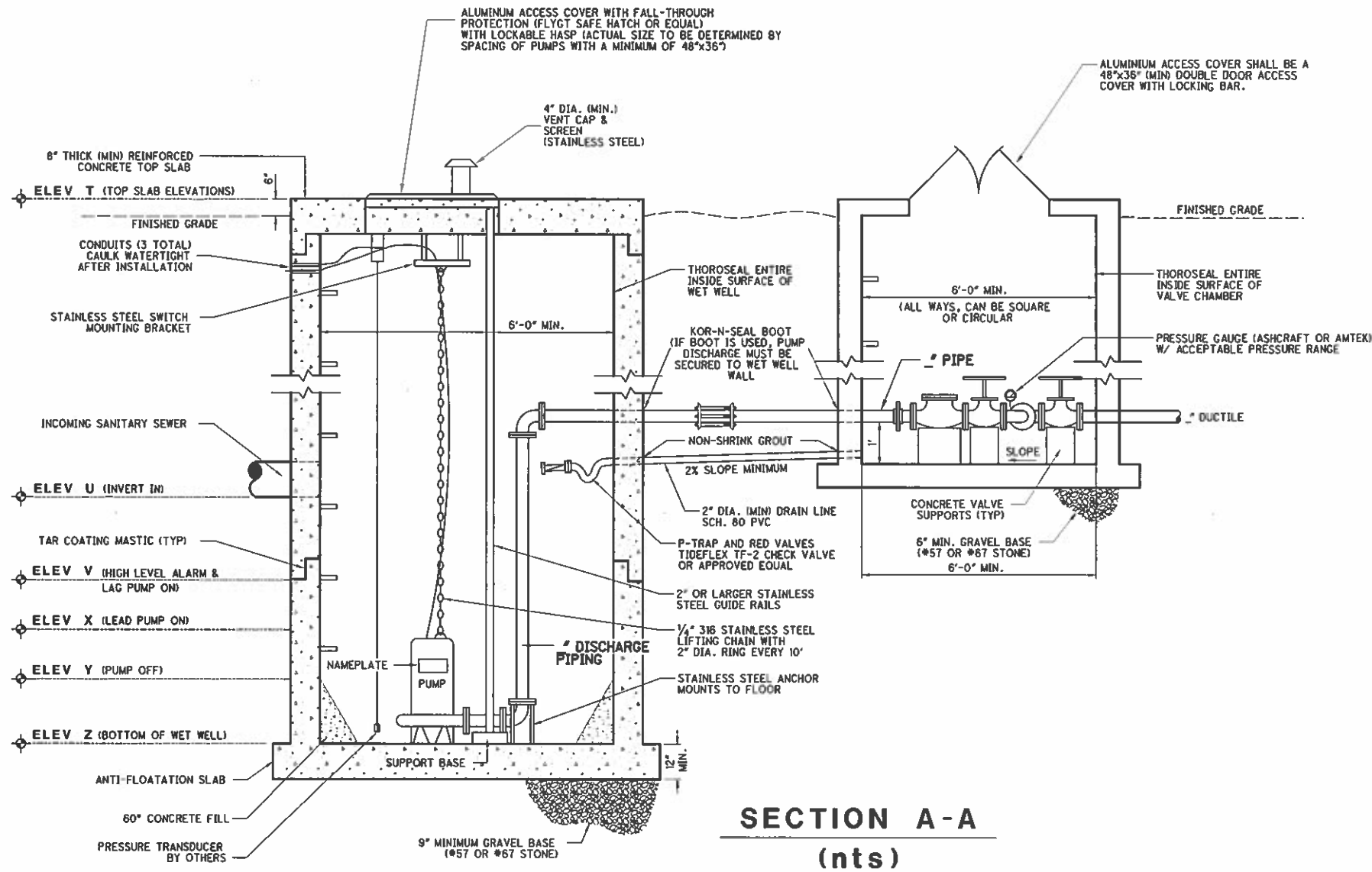

DATES - TIMES - REVISIONS - BY

CITY OF HEATH
DIRECTOR OF UTILITIES
DATE
10-2005
03-2022
STANDARD CONSTRUCTION DRAWING
SANITARY PUMP STATION
NUMBER
SA-11
1 / 3

SCOPE OF WORK

THE CONTRACTOR SHALL, UNLESS OTHERWISE NOTIFIED, FURNISH ALL LABOR, MATERIALS, EQUIPMENT, TOOLS, AND INCIDENTALS NECESSARY TO INSTALL, TEST, COMPLETE AND MAKE READY FOR OPERATION A SUBMERSIBLE SEWAGE PUMP STATION. THIS INCLUDES THE FURNISHING AND INSTALLATION OF ALL NECESSARY AND DESIRABLE ACCESSORY EQUIPMENT AND AUXILIARIES, WHETHER SPECIFICALLY MENTIONED IN THESE SPECIFICATIONS OR NOT, AS REQUIRED FOR A SUCCESSFUL INSTALLATION. THIS INCLUDES INSTALLATION OF A ONE(1) INCH WATER SERVICE AND FROST FREE YARD HYDRANT AT EACH PUMP STATION FOR MAINTENANCE PURPOSES.

THE CONTRACTOR SHALL BE RESPONSIBLE FOR ALL EXCAVATION AND REMOVAL OF OBSTRUCTIONS AND RESTORATION OF ALL PROPERTIES INVOLVED DIRECTLY WITH THE CONSTRUCTION AND OR INSTALLATION OF THE PUMP STATION.

THE CONTRACTOR SHALL ALLOW A MINIMUM OF 4 HOURS OF ON-SITE START-UP TRAINING WITH THE CITY OF HEATH PERSONNEL. THE TRAINING SHALL BE PROVIDED BY A CERTIFIED MANUFACTURER'S REPRESENTATIVE SERVICE TECHNICIAN. THIS TRAINING SHALL TAKE PLACE PRIOR TO ACCEPTANCE BY THE CITY.

INSPECTION

MATERIALS PROVIDED AND WORK PERFORMED SHALL BE SUBJECT TO INSPECTIONS BY CITY REPRESENTATIVES AND/OR BY APPOINTED AGENTS OF THE CITY. ACCEPTANCE OF THE PUMP STATION SHALL BE CONTINGENT ON THE CONDITION THAT ALL MATERIALS, EQUIPMENT, AND WORKMANSHIP PROVIDED PASS SET INSPECTIONS, SATISFACTORY COMPLETION OF ALL WORK AND PROPER OPERATION OF THE COMPLETED PUMP STATION.

WARRANTY

A TWELVE (12) MONTH WARRANTY SHALL BE PROVIDED FOR THE PUMP STATION. THIS WARRANTY SHALL BEGIN ON THE DATE THE PUMP STATION IS ACCEPTED BY THE CITY OF HEATH FOR OPERATION. THE WARRANTY SHALL COVER THE FOLLOWING:

1. ALL EQUIPMENT, PARTS, AND LABOR.
2. SITE MATERIALS, ROADWAYS, AND FENCES.
3. GROUND SUBSIDENCE AND SETTLEMENT OF VALVE VAULT AND WET WELL.
4. LANDSCAPING AND SCREENING PLANTINGS.

THE PUMPS SHALL HAVE AT LEAST AN EIGHTEEN (18)-MONTH FULL (ALL PARTS AND LABOR) MANUFACTURER'S WARRANTY AND 5-YEAR PRORATED MANUFACTURER'S WARRANTY, WHICH SHALL BOTH BEGIN NO EARLIER THAN THE DATE OF SHIPMENT TO THE CONTRACTOR. IN THE EVENT THAT THE PUMP STATION IS NOT ACCEPTED WITHIN SIX MONTHS OF SHIPMENT OF THE PUMPS, THE FULL WARRANTY SHALL BE EXTENDED TO TWELVE MONTHS FROM THE DATE THE PUMP STATION IS ACCEPTED BY THE CITY FOR OPERATION.

TOOLS AND SPARE PARTS

ALL SPECIAL TOOLS AND RECOMMENDED SPARE PARTS REQUIRED FOR NORMAL OPERATION AND MAINTENANCE SHALL BE SUPPLIED FOR EACH PIECE OF EQUIPMENT FURNISHED.

THE FOLLOWING SPARE PARTS SHALL BE FURNISHED AS A MINIMUM:

1. ONE (1) SPARE PUMP
2. ONE (1) SET OF 1 UPPER AND 1 LOWER MECHANICAL SEALS AND A SEAL TOOL.
3. ONE (1) SET OF GASKETS, O-RINGS, GROMMETS, AND OTHER SEALING DEVICES.
4. ONE (1) ROTATING WEAR RING (IF SO EQUIPPED) OR A SPARE IMPELLER, AND ONE (1) STATIONARY WEAR RING (IF SO EQUIPPED) OR A SPARE VOLUTE.
5. ONE (1) COMPLETE SET OF SPARE FUSES FOR ALL ELECTRICAL DEVICES.
6. TEN SPARE BULBS FOR EACH LAMP USED.

ALL SPARE PARTS SHALL BE DELIVERED TO THE CITY PRIOR TO FINAL COMPLETION AND START OF THE WARRANTY PERIOD.

SHOP DRAWINGS AND PUMP CURVE

THE CONTRACTOR SHALL SUBMIT FIVE (5) COPIES OF ALL SHOP DRAWINGS FOR APPROVAL PRIOR TO ORDERING. SHOP DRAWINGS SHALL BE SUBMITTED TO THE ENGINEER FOR SUBMITTAL TO THE CITY FOR APPROVAL PRIOR TO CONSTRUCTION. THEY SHALL CONSIST OF COMPLETE DIMENSION DRAWINGS INCLUDING LOCATION OF PUMPS, PIPING, HATCHES, VALVES, AND OTHER ACCESSORIES.

OPERATION AND MAINTENANCE MANUALS

FOUR(4) COMPLETE SETS OF INSTALLATION, OPERATION AND MAINTENANCE INSTRUCTIONS SHALL BE PROVIDED FOR ALL EQUIPMENT AND ELECTRICAL COMPONENTS. THE MANUALS SHALL BE PREPARED SPECIFICALLY FOR THE INSTALLATION TO WHICH THEY PERTAIN AND SHALL INCLUDE ALL AVAILABLE INSTALLATION MANUALS, OPERATION MANUALS, MAINTENANCE MANUALS, CATALOG CUTS, DRAWINGS, WIRING DIAGRAMS, EQUIPMENT AND PARTS LIST, LIST OF SPARE PARTS PROVIDED, WARRANTIES, PRODUCT DESCRIPTIONS, ETC. ALL FOUR(4) SETS OF MANUALS FOR MAJOR EQUIPMENT SHALL BE ORIGINAL MANUFACTURER'S MANUALS, COPIES WILL NOT BE ACCEPTABLE. ONLY ONE(1) SET OF ORIGINAL MANUFACTURER'S LITERATURE IS REQUIRED FOR MISCELLANEOUS COMPONENTS; COPIES OF THIS LITERATURE WILL BE ACCEPTABLE FOR THE OTHER THREE(3) O & M MANUALS.

RECORD DRAWINGS

THE RECORD DRAWING SUBMITTAL SHALL BE AS PER GENERAL NOTE G18 WITH THE ADDITIONS/REVISIONS DESCRIBED WITHIN THIS SECTION.

1. RECORD DRAWINGS SHALL LEGIBLY MARKED TO RECORD ACTUAL CONSTRUCTION INCLUDING:

- a. ALL DEVIATIONS IN HORIZONTAL OR ELEVATION OF ANY UNDERGROUND INSTALLATION FROM THAT SHOWN ON THE CONTRACT DRAWINGS.
- b. ANY SIGNIFICANT CHANGES IN ABOVE GROUND INSTALLATIONS FROM THE APPROVED SHOP DRAWINGS OR CONTRACT DRAWINGS.
- c. INDICATION OF THE CITY OF HEATH'S APPROVAL OF ANY SUCH DEVIATIONS OR CHANGES FROM THE CONTRACT DRAWINGS OR APPROVED SHOP DRAWINGS.

2. SPECIFICATIONS AND ADDENDA SHALL BE LEGIBLY MARKED TO RECORD:

- a. MANUFACTURER, TRADE NAME, CATALOG NUMBER, AND SUPPLIER OF EACH PRODUCT AND ITEM OF EQUIPMENT ACTUALLY INSTALLED.
- b. CHANGES MADE BY CHANGE ORDER OR FIELD ORDER.
- c. OTHER MATTERS NOT ORIGINALLY SPECIFIED.

3. SHOP DRAWINGS SHALL BE LEGIBLY ANNOTATED TO RECORD CHANGES MADE AFTER REVIEW.

STRUCTURES

THE WET WELL AND VALVE PIT SHALL BE CONSTRUCTED OF MANHOLE SECTIONS IN ACCORDANCE ASTM C478 WITH WATERTIGHT RUBBER GASKETED JOINTS PER ASTM C443. STRUCTURE JOINTS SHALL ALSO BE PROVIDED WITH A FIELD APPLIED MASTIC SEAL. THE BASE SECTION SHALL CONSIST OF A RISER SECTION WITH A 12-INCH THICK INTEGRAL FLOOR AND SIX(6) INCH ANTI FLOTATION LIP AROUND THE EXTERIOR. THE TOP SHALL BE FLAT AND BE PRECAST CONCRETE WITH A MINIMUM TWELVE(12) INCH THICKNESS. THE WET WELL AND VALVE PIT SHALL BE CAPABLE OF HS-20 HIGHWAY LOADING.

TESTING

THE WET WELL AND VALVE VAULT SHALL BE TESTED PRIOR TO BACKFILLING AS FOLLOWS: THE VAULTS SHALL BE FILLED WITH WATER FOR TWENTY-FOUR (24) HOURS AND ANY VISIBLE LEAKS REPAIRED IMMEDIATELY. IF THE WATER LEVEL DROPS MORE THAN TWELVE(12) INCHES WITHIN TWENTY-FOUR(24) HOURS, THE STRUCTURE FAILS THE TEST AND THE CONTRACTOR SHALL MAKE THE NECESSARY REPAIRS TO PASS THE TEST.

ACCESS COVERS

EACH STRUCTURE (WET WELL AND VALVE PIT) SHALL HAVE AN ACCESS COVER. ACCESS COVERS SHALL BE ALUMINUM WITH 316 STAINLESS STEEL HARDWARE AND FLUSH MOUNTED. THE COVERS SHALL BE RATED FOR THREE HUNDRED (300) POUNDS PER SQUARE FOOT LOADING. THE FINISH SHALL BE CHECKERED, DIAMOND PLATE OR OTHER APPROVED NON-SLIP SURFACE. THE VALVE VAULT SHALL HAVE A MINIMUM DIMENSION OF 36"X 48". THE WET WELL SHALL HAVE FLYGT SAFE HATCH (OR APPROVED EQUAL) WHICH PROVIDES THE MAXIMUM SIZE OPENING. AT A MINIMUM, THE WET WELL HATCH SHALL PROVIDE A TWELVE(12) INCH CLEARANCE FROM THE BACK OF THE PUMP VOLUTE (AWAY FROM THE SLIDE RAILS) TO THE EDGE OF THE OPENING TO FACILITATE EASY REMOVAL.

PIPES

THE FORCE MAIN SHALL BE PVC AWWA C900, DR 18 WITH A CELL CLASSIFICATION AS DEFINED IN ASTM D1784 OR 12454 B OR C OR CLASS 53 DUCTILE IRON MEETING ANSI/AWWA C151/A21.51. FITTINGS SHALL BE DUCTILE IRON CONFORMING TO EITHER ANSI/AWWA C110/A21.10 OR ANSI/AWWA C153/A21.53. FITTINGS SHALL HAVE A STANDARD ASPHALTIC COATING ON THE EXTERIOR.

PIPING AT THE PUMP STATION SHALL BE OF CLASS 53 DUCTILE IRON MEETING ANSI/AWWA C151/A21.51. ALL PIPES SHALL BE CEMENT-LINED, MEETING ANSI/AWWA C104/A21.4 STANDARDS WITH ASPHALTIC SEAL COATING ON THE INTERIOR.

ALL MATING ENDS IN THE PUMP STATION AND VALVE PIT SHALL BE CLASS 125 FLANGED MEETING ANSI/AWWA C110/A21.10 AND C115/A21.15, WITH A GASKET NO LARGER THAN 0.125 INCH BETWEEN FLANGES. FLANGE ADAPTORS SUCH AS UNION FLANGE WILL NOT BE ALLOWED. ALL FLANGES SHALL BE DUCTILE IRON, NOT GRAY IRON. ALL FLANGE BOLTS SHALL BE 316 STAINLESS STEEL. EXTERIOR OF PIPES IN THE WET WELL AND VALVE PIT SHALL BE COATED WITH EPOXY-BASED PAINT, IN ACCORDANCE WITH AWWA STANDARDS. ONLY ONE JOINT OR FITTING WILL BE PERMITTED ON EACH PIPE BETWEEN THE WET WELL AND THE VALVE PIT. THIS SHALL BE A RESTRAINED FLEXIBLE JOINT SUCH AS A MECHANICAL-JOINT SOLID SLEEVE WITH MEGALUGS. NOT FLANGED JOINTS WILL BE PERMITTED OUTSIDE THE WET WELL AND VALVE PIT.

SWING CHECK VALVES

CHECK VALVES SHALL HAVE EXTERIOR WEIGHTED ARMS AND CONFORM THE AWWA C-508. VALVES SHALL BE CAST IRON BODY WITH A BRONZE MOUNTED, SINGLE-DISC, 175 PSI WORKING PRESSURE. VALVE SHALL BE COATED IN ACCORDANCE WITH AWWA C-550.

GATE VALVES

GATE VALVES SHALL BE CONFORM TO THE REQUIREMENTS OF AWWA C-509, SHALL HAVE A NON-RISING STEM, HAND WHEEL W/ LEFT HAND OPEN (COUNTER-CLOCKWISE) WITH DOUBLE O-RING STEM SEALS. VALVES SHALL BE FURNISHED WITH CLASS 125 FLANGED ENDS.

VALVES SHALL PASS A SEAT TEST AT A PRESSURE OF 200 PSI WITHOUT LEAKAGE. THE VALVE SHELL SHALL PASS A SHELL TEST WITH THE VALVE IN THE OPEN POSITION AT A PRESSURE OF 400 PSI WITHOUT LEAKAGE THROUGH METAL, FLANGED JOINTS OR STEM SEALS.

RESILIENT-SEATED VALVES SHALL BE COATED, INTERIOR, EXTERIOR, AND VALVE BONNET, WITH FUSION-BONDED EPOXY, IN ACCORDANCE WITH AWWA C-550.

ELECTRICAL

ALL ELECTRICAL WORK FOR THIS PROJECT SHALL BE INSTALLED IN ACCORDANCE WITH THE LATEST EDITIONS OF THE NATIONAL ELECTRIC CODE (NEC) AND ALL STATE AND LOCAL CODES. SAID CODES SHALL BE CONSIDERED THE MINIMUM STANDARD FOR MATERIALS AND METHODS NOT OTHERWISE COVERED IN THIS SPECIFICATION.

ALL ELECTRICAL COMPONENTS SHALL MEET NEMA STANDARDS, AND SHALL COMPLY WITH NEC AND UL AS APPLICABLE TO CONSTRUCTION AND INSTALLATION OF WIRING AND COMPONENTS. THE ELECTRICAL SYSTEM INSIDE THE WET WELL SHALL COMPLY WITH THE NATIONAL ELECTRIC CODE FOR HAZARDOUS LOCATIONS, CLASS I, DIVISION 1, GROUP D.

ALL WIRING SHALL BE INSTALLED IN CONDUIT. RIGID GALVANIZED STEEL CONDUIT SHALL BE USED FOR ALL ABOVE GRADE WIRING. SCHEDULE 80 PVC WITH GLUED JOINTS SHALL BE USED FOR WIRING INSTALLED BELOW GRADE. ALL CONDUITS SHALL BE TAGGED AND IDENTIFIED WITH BRASS TAGS HELD ON BY COPPER WIRE AT BOTH ENDS.

ALL WIRE SHALL BE STRANDED COPPER WITH THIN INSULATION. CONDUCTOR SIZES SHALL BE SELECTED SO THAT THE MAXIMUM VOLTAGE DROP DOES NOT EXCEED 3% OF THE NOMINAL SERVICE VOLTAGE FOR THE ENTIRE LENGTH OF THE CIRCUIT INVOLVED. CALCULATIONS SHALL BE BASED ON RESISTANCE VALUES STATED IN CHAPTER 9 OF NEC.

SERVICE DISCONNECT

AFTER THE ELECTRIC METER, A FUSED DISCONNECT SHALL BE PROVIDED. THE FUSED DISCONNECT SHALL BE SERVICE ENTRANCE RATED (PER ARTICLE 230-66 NEC), NEMA 4X, STAINLESS STEEL, FUSED DISCONNECT. PROVIDE ONE (1) ADDITIONAL CLASS KR-5 FUSE FOR EACH FUSE NEEDED. A SURGE ARRESTER SHALL BE PROVIDED ON THE LOAD SIDE OF THE DISCONNECT. THE DISCONNECT SHALL BE PADLOCKABLE IN THE ON AND OFF POSITION.

LEVEL CONTROL SYSTEM

THE LEVEL CONTROL SYSTEM SHALL PROVIDE FOR THE AUTOMATIC AND MANUAL CONTROL AND ALTERNATION OF PUMPS TO MAINTAIN A PUMPED DOWN/UP CONDITION OF THE WET WELL. LEVELS SHALL BE SENSED BY CONDUCTIVE PROBES ADJUSTED TO THE LEVELS DEPICTED ON THE PLANS. THE PROBES SHALL SENSE THE OFF AND ON AND ALARM LEVELS WITHIN THE WET WELL. PROBE SHALL BE MANUFACTURED BY MULTITRODE AND CONTROLLED WITH A MULTITRODE MT2PC.

CITY OF HEATH
DIRECTOR OF UTILITIES

DATE
10-2005
03-2022

STANDARD CONSTRUCTION DRAWING
SANITARY PUMP STATION

NUMBER
SA-11

2 / 3

CONTROL PANEL NOTES

THE CONTROL PANEL SHALL BE ASSEMBLED IN A STAINLESS STEEL NEMA 4X WEATHER-PROOF ENCLOSURE WITH STAINLESS STEEL LOCKING HASP AND HINGES. AN INTERIOR DOOR SHALL BE PROVIDED FOR DEAD FRONT ACCESS TO BREAKERS AND CONTROLS. THE ENCLOSURE SHALL BE MOUNTED ON STAINLESS STEEL UNISTRUTS ON THE WET WELL, IN A LOCATION PRACTICAL FOR FUTURE OPERATION OF THE STATION. THE MOUNTING SHALL BE COMPLETED IN A MANNER THAT PROVIDES THE NECESSARY STRENGTH TO ADEQUATELY SUPPORT THE PANEL.

MOTORS SHALL OPERATE ON A LEAD-LAG SCHEME WITH AN ALTERNATING RELAY TO CONTROL ALTERNATION OF THE LEAD PUMP. A CONTROL POWER TRANSFORMER SHALL PROVIDE 120 VAC. EACH PUMP SHALL BE FURNISHED WITH A HAND-OFF-AUTOMATIC SWITCH AND A RUN PILOT LIGHT.

A MINIMUM OF THE FOLLOWING COMPONENTS SHALL BE INSTALLED ON THE INNER CONTROL PANEL DOOR:

- PAD LOCKABLE DOOR
- MULTITRODE CONTROLLER (MT2PC OR RECOMMENDED) INTERLOCKING ROTARY HANDLES FROM PUMP MOTOR
- PROTECTIVE BREAKERS
- HAND-OFF-AUTOMATIC SELECTOR SWITCHES
- SIX-DIGIT, NON RESET ELAPSED TIME METERS (x3):
PUMP 1, PUMP 2, PUMP 1 & PUMP 2 COMBINED
- INDICATOR LIGHTS FOR:
PUMP RUNNING

A MINIMUM OF THE FOLLOWING COMPONENTS SHALL BE MOUNTED AT THE MOUNTING BACK PLATE:

- FUSELESS COMBINATION NEMA RATED STARTERS WITH INSTANTANEOUS SHORT CIRCUIT PROTECTION
- HEAVY DUTY INDUSTRIAL CONTACTORS
- THREE-PHASE ADJUSTABLE BIMETALLIC OVERLOAD PROTECTION
- CONTROL CIRCUIT TRANSFORMER WITH PRIMARY CIRCUIT BREAKER AND SECONDARY CIRCUIT BREAKERS FOR:
 - CONTROL
 - DUPLEX RECEPTACLE
 - AUTOMATIC ELECTRICAL ALTERNATION
 - CONTROL RELAYS
 - AUTOMATIC SHUTOFF TIMER FOR ALARM HORN
 - LIGHTENING ARRESTOR
 - POWER TERMINALS AND CONTROL TERMINALS
 - CONDENSATION PROTECTIVE SPACE HEATER WITH THERMOSTAT
- PHASE FAILURE RELAY WITH A TWO-SECOND DELAY TRIP AND SIXTY SECOND DELAY ON TIME, WHICH WILL MONITOR:
 - PHASE FAILURE
 - PHASE REVERSAL
 - LOW VOLTAGE (BROWN OUT)
- THE ALARM LIGHT AND HORN SHALL BE ON AT:
 - HIGH LEVEL
 - SEAL ALARM
 - PUMP BREAKER TRIPPED
 - OVERLOAD
 - MOTOR OVER TEMPERATURE

STANDBY POWER

STANDBY POWER SHALL BE PROVIDED IN FORM OF A PERMANENT ON-SITE DIESEL GENERATOR (KOHLER OR APPROVED EQUAL COMPATIBLE WITH THE MAIN POWER SUPPLY). THE GENERATOR SHALL BE CAPABLE OF SUPPLYING EMERGENCY BACKUP POWER FOR BOTH PUMPS AND OTHER ELECTRICAL COMPONENTS. PROVISIONS FOR SEQUENTIAL PUMP STARTING SHALL BE MADE TO MINIMIZE GENERATOR SIZE AND PREVENT OVERLOADING.

THE GENERATOR SHALL BE EQUIPPED WITH A FUEL TANK CAPABLE OF SUPPLYING FUEL SUFFICIENT FOR A MINIMUM OF 24 HOURS OF OPERATION AT A FULL LOAD. THE TANK SHALL BE SELF CONTAINED AND DOUBLE-WALLED WITH A MECHANICAL FUEL GAUGE, LOW-LEVEL FUEL SWITCH, AND LEAK DETECTION.

OTHER REQUIRED EQUIPMENT SHALL INCLUDE A RADIATOR COOLANT SYSTEM ELECTRIC BLOCK HEATER, FLEXIBLE FUEL LINES, LINE CIRCUIT BREAKER (100 AMP MIN.), SAFEGUARD BREAKERS, OIL DRAIN EXTENSION, VOLTAGE REGULATOR, OVERVOLTAGE SHUTDOWN PROTECTION, 12 OR 24 VOLT BATTERY PACK AND AUTOMATIC FLOAT BATTERY CHARGER, VIBRATION ISOLATORS, ALARM HORN WITH SILENCING SWITCH, RESIDENTIAL-GRADE EXHAUST MUFFLER, TAIL PIPE, AND RAIN CAP. A SOUND-ATTENUATING TREATMENT SHALL BE PROVIDED TO REDUCE SOUND LEVELS NO MORE THAN 85dba AT 50 FEET FROM THE ENCLOSURE.

THE AUTOMATIC TRANSFER SWITCH (ATS) SHALL BE ELECTRICALLY OPERATED TYPE THAT IS MECHANICALLY HELD IN BOTH OPERATING POSITIONS WITH TIME DELAY NEUTRAL POSITION. THE ATS SHALL BE SUITABLE FOR USE IN STANDBY SYSTEMS DESCRIBED IN NFPA 70. THE ATS SHALL HAVE A STAINLESS STEEL NEMA 4X ENCLOSURE WITH A HEATER AND DRIP SHIELD. ALL SWITCHES, LIGHTS, AND OTHER CONTROLS FOR THE TRANSFER SWITCH SHALL BE MOUNTED INTERNAL TO THE ENCLOSURE EITHER ON AN INNER DOOR OR AN INNER STAND-OUT. NO CONTROLS SHALL BE MOUNTED THROUGH THE OUTSIDE OF THE ENCLOSURE.

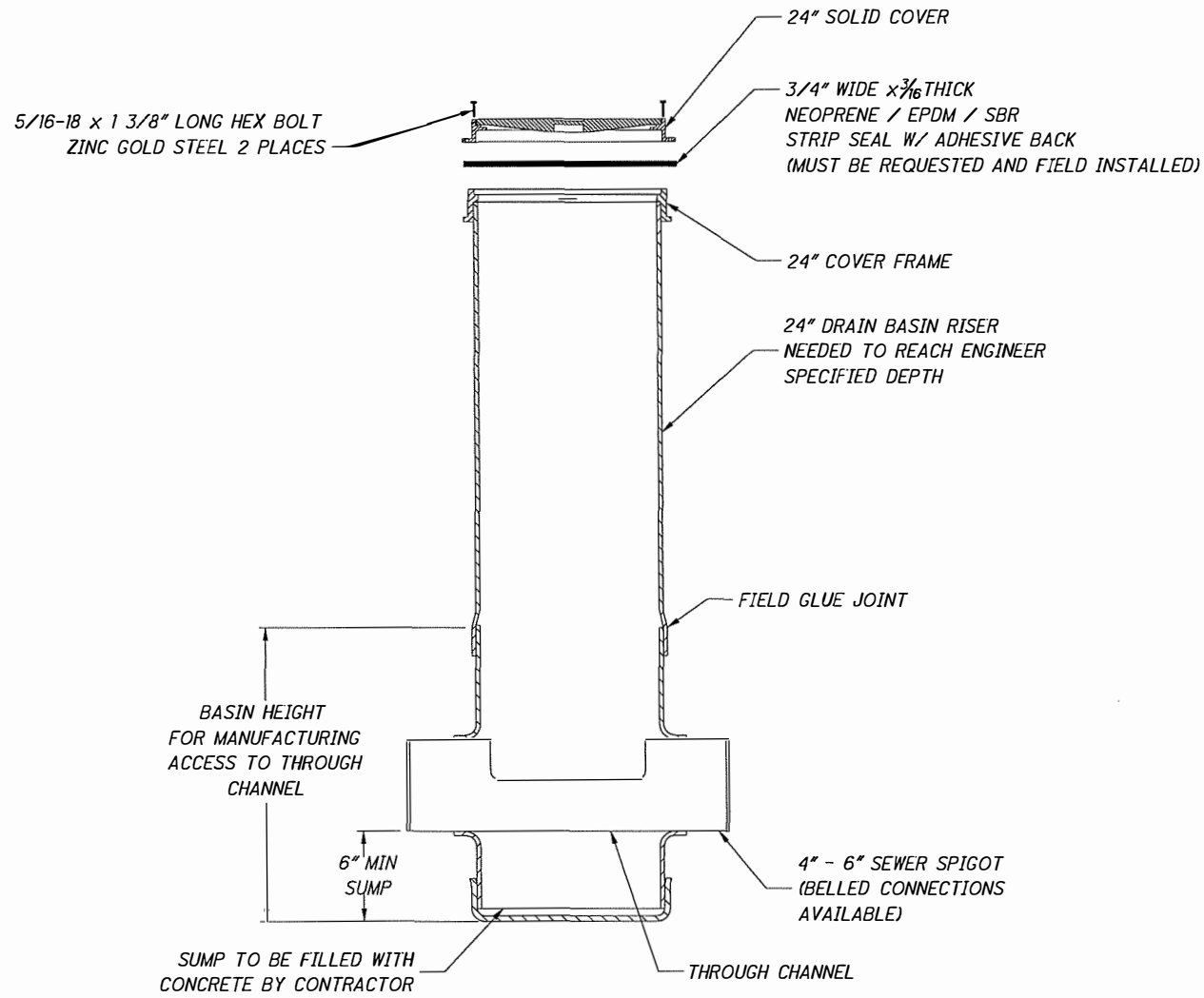

VIEW A-A
ROTATED 90° CLOCKWISE WITH
BASIN SECTIONED TO SHOW DETAIL OF
THROUGH CHANNEL

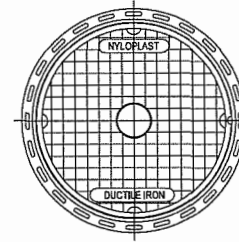

FRAME & COVER TOP VIEW
WITHOUT BASIN BODY
4" - 6" @ 180°

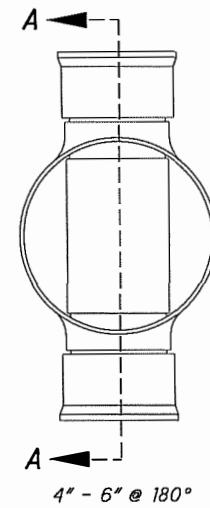

BASIN BODY TOP VIEW
WITHOUT FRAME AND GRATE
4" - 6" @ 180°

WOO - WATER WORK

ALL WATER PIPE, FITTINGS, METHODS OF CONSTRUCTION, AND WORKMANSHIP FOR WATER LINES AND APPURTENANCES SHOWN ON THESE PLANS SHALL CONFORM TO THE RULES AND REGULATIONS OF THE CITY OF HEATH, DIVISION OF WATER, AND ODOT ITEM 638 CURRENT ON THE DATE OF CONTRACT UNLESS THE REQUIREMENTS OF SUCH RULES AND REGULATIONS ARE UPGRADED BY THE FOLLOWING NOTES OR BY THE CONSTRUCTION DETAILS SET FORTH HEREIN.

OPERATION OF IN SERVICE VALVES SHALL BE BY WATER DIVISION PERSONNEL ONLY. A 72 HOUR NOTICE SHALL BE REQUIRED FOR SHUT DOWNS.

MATERIALS

ALL WATER MAIN MATERIALS MUST MEET AWWA SPECIFICATIONS AND A STATEMENT OF VERIFICATION MUST BE FURNISHED TO THE CITY.

ALL VALVES SHALL BE A RESILIENT WEDGE GATE VALVE WITH NON RISING STEM STAINLESS-STEEL TRIM & EPDMENCAPSULATED WEDGE, SIZE 3" THROUGH 16". ALL VALVES SHALL BE AMERICAN AVK OR APPROVED EQUAL. ALL BOLTS, NUTS AND WASHERS SHALL BE 304 STAINLESS STEEL.

FIRE HYDRANTS SHALL BE AMERICAN AVK 2780 OR APPROVED EQUAL WITH 6" GATE VALVE.

ALL BENDS, JOINTS, DEFLECTIONS AND FITTINGS SHALL BE APPROPRIATELY RESTRAINED, AS PER CITY OF HEATH STANDARD DRAWINGS AND ODOT SPECIFICATION 638.06.

ALL WATER MAINS SHALL BE CONSTRUCTED OF DUCTILE IRON PIPE (CLASS 52) OR PVC, C-900 (DR-14). DUCTILE IRON PIPE SHALL BE CEMENT LINED WITH BITUMINOUS COATING, INSTALLED AS PER AWWA STANDARDS.

ALL FITTINGS SHALL BE DUCTILE IRON, MECHANICAL JOINT AND SHALL COMPLY WITH AWWA SPECIFICATIONS. TAPPING SADDLES MUST BE EPOXY COATED OR 304 STAINLESS STEEL.

SERVICE LINES SHALL BE OF COPPER, NOT LESS THAN THREE-QUARTER INCH OR "CTS", 200 PSI, WITH STAINLESS STIFFENERS, BURIED WITH TRACE WIRE AND SHALL BE COVERED TO A DEPTH OF 4.5 FT.

ALL MAINLINE TEE BOLTS SHALL BE 304 STAINLESS STEEL.

ALL THREADED RODS SHALL BE 3/4" AND 304 STAINLESS STEEL.

ALL PIPE INSTALLED SHALL HAVE UNDERGROUND LOCATING TAPE (BLUE) INSTALLED 2 FEET ABOVE THE UTILITY PIPE. LOCATING TAPE SHALL HAVE 18 INCHES OF COVER. ALL PIPE SHALL REQUIRE COPPERHEAD INDUSTRIES, LLC, COPPERHEAD HIGH STRENGTH REINFORCED TRACE WIRE, OR APPROVED EQUAL, INTENDED FOR DIRECT BURY, COLOR CODED PER APWA STANDARD FOR THE WATERLINE BEING MARKED, CAPABLE OF DETECTION BY A LOCATOR. TRACE WIRE SHALL BE INSTALLED ON THE BOTTOM HALF OF THE PIPE BELOW THE SPRING LINE AND SHALL REACH THE TOP OF EACH VALVE BOX. THE TRACE WIRE SHALL BE FASTENED TO THE PIPE WITH DUCT TAPE OR PLASTIC TIES AT 5' INTERVALS.

ALL TRACE WIRE AND TRACE WIRE PRODUCTS SHALL BE DOMESTICALLY MANUFACTURED IN THE U.S.A.

TRACE WIRE:
OPEN TRENCH - TRACE WIRE SHALL BE COPPERHEAD INDUSTRIES, LLC, I230-HS, OR APPROVED EQUAL.

DIRECTIONAL DRILLING/BORING - TRACE WIRE SHALL BE COPPERHEAD INDUSTRIES, LLC, I245-EHS, OR APPROVED EQUAL.

MATERIALS CONTINUED:

TRACE WIRE - PIPE BURSTING/SLIP LINING - TRACE WIRE SHALL BE COPPERHEAD INDUSTRIES, LLC, PBX-50, OR APPROVED EQUAL.

INSTALLATION:
TRACE WIRE INSTALLATION SHALL BE PERFORMED IN SUCH A MANNER THAT ALLOWS PROPER ACCESS FOR CONNECTION OF LINE TRACING EQUIPMENT, PROPER LOCATING OF WIRE WITHOUT LOSS OR DETERIORATION OF LOW FREQUENCY (512 HZ) SIGNAL FOR DISTANCES IN EXCESS OF 1,000 LINEAR FEET, AND WITHOUT DISTORTION OF SIGNAL CAUSED BY MULTIPLE WIRES BEING INSTALLED IN CLOSE PROXIMITY TO ONE ANOTHER.

LAY MAINLINE TRACE WIRE CONTINUOUSLY, BY-PASSING AROUND THE OUTSIDE OF VALVES AND FITTINGS ON THE NORTH OR EAST SIDE.

TRACER WIRE MUST TERMINATE AT AN APPROVED ABOVE-GROUND TRACE WIRE BOX, PROPERLY AFFIXED TO THE HYDRANT GRADE FLANGE. (AFFIXING WITH DUCT TAPE OR PLASTIC TIES SHALL NOT BE ACCEPTABLE)

IN ALL CASES THE DISTANCE BETWEEN ANODE RODS/ACCESS BOXES SHALL NOT EXCEED 1000 LINEAR FEET.

TRACE WIRE SYSTEMS MUST BE INSTALLED AS A SINGLE CONTINUOUS WIRE, EXCEPT WHERE USING APPROVED CONNECTORS. NO LOOPING OR COILING OF WIRE IS ALLOWED.

ANY DAMAGE OCCURRING DURING INSTALLATION OF THE TRACE WIRE MUST BE IMMEDIATELY REPAIRED BY REMOVING THE DAMAGED WIRE, AND INSTALLING A NEW SECTION OF WIRE WITH APPROVED CONNECTORS. TAPING AND/OR SPRAY COATING SHALL NOT BE ALLOWED.

TRACE WIRE SHALL BE INSTALLED ON THE BOTTOM HALF OF THE PIPE BELOW THE SPRING LINE AND SHALL REACH THE TOP OF EACH VALVE BOX. THE TRACE WIRE SHALL BE FASTENED TO THE PIPE WITH DUCT TAPE OR PLASTIC TIES AT 5' INTERVALS.

TRACE WIRE MUST BE PROPERLY GROUNDED AS SPECIFIED.

TRACE WIRE ON ALL SERVICE LATERALS/STUBS MUST TERMINATE AT AN APPROVED ACCESS BOX. (SEE TRACE WIRE TERMINATION/ACCESS)

AT ALL MAINLINE DEAD-ENDS, TRACE WIRE SHALL GO TO GROUND USING AN APPROVED CONNECTION TO A GROUNDING ANODE. (SEE GROUNDING)

MAINLINE TRACE WIRE SHALL NOT BE CONNECTED TO EXISTING CONDUCTIVE PIPES. TREAT AS A MAINLINE DEAD-END, GROUND USING AN APPROVED WATERPROOF CONNECTION TO A GROUNDING ANODE BURIED AT THE SAME DEPTH AS THE TRACE WIRE.

ALL SERVICE LATERAL TRACE WIRE SHALL BE A SINGLE WIRE, CONNECTED TO THE MAINLINE TRACE WIRE USING A MAINLINE TO LATERAL CONNECTOR, INSTALLED WITHOUT CUTTING/SPlicing THE MAINLINE TRACE WIRE.

IN OCCURRENCES WHERE AN EXISTING TRACE WIRE IS ENCOUNTERED ON AN EXISTING UTILITY THAT IS BEING EXTENDED OR TIED INTO, THE NEW TRACE WIRE AND EXISTING TRACE WIRE SHALL BE CONNECTED USING APPROVED CONNECTORS, AND SHALL BE PROPERLY GROUNDED AT THE LOCATION AS SPECIFIED.

MATERIALS CONTINUED:

CONNECTORS:
ALL MAINLINE TRACE WIRES MUST BE INTERCONNECTED IN INTERSECTIONS, AT MAINLINE TEES AND MAINLINE CROSSES. AT TEES, THE THREE WIRES SHALL BE JOINED USING A SINGLE CONNECTOR. AT CROSSES THE FOUR WIRES SHALL BE JOINED USING A CONNECTOR. USE OF TWO CONNECTORS WITH A SHORT JUMPER WIRE BETWEEN THEM IS AN ACCEPTABLE ALTERNATIVE.

DIRECT BURY WIRE CONNECTORS - SHALL INCLUDE CONNECTORS AND MAINLINE TO LATERAL CONNECTORS SPECIFICALLY MANUFACTURED FOR USE IN UNDERGROUND TRACE WIRE INSTALLATION. CONNECTORS SHALL BE COPPERHEAD INDUSTRIES, LLC, DRYCONN 3-WAY DIRECT BURY LUG, FILLED TO SEAL OUT MOISTURE AND CORROSION, AND SHALL BE INSTALLED IN A MANNER SO AS TO PREVENT ANY UNINSULATED WIRE EXPOSURE.

NON-LOCKING FRICTION FIT, TWIST ON OR TAPED CONNECTORS ARE PROHIBITED.

WRAPPING OF TRACE WIRE AT TREES/HYDRANTS IS PROHIBITED. CONNECTORS SHALL BE INSTALLED.

TERMINATION/ACCESS:
ALL TRACE WIRE TERMINATION POINTS MUST UTILIZE COPPERHEAD INDUSTRIES, LLC, LD14 TP (FOR NON-ROADWAY APPLICATIONS) AND RB14 TP (FOR HIGH TRAFFIC ROADWAYS), OR APPROVED EQUAL, ABOVE GROUND OR GRADE LEVEL/IN-GROUND, AS APPLICABLE, SPECIFICALLY MANUFACTURED FOR THIS PURPOSE.

ALL ACCESS BOXES, SHALL BE APPROPRIATELY IDENTIFIED WITH "WATER" CAST INTO THE CAP AND BE COLOR CODED BLUE.

A MINIMUM 2 FT. OF EXCESS/SLACK WIRE IS REQUIRED IN ALL ACCESS BOXES AFTER MEETING FINAL ELEVATION.

ALL ACCESS BOXES MUST INCLUDE A MANUALLY INTERRUPTIBLE CONDUCTIVE LINK BETWEEN THE TERMINAL(S) FOR THE CONNECTION AND THE TERMINAL FOR THE GROUNDING ANODE WIRE CONNECTION.

GROUNDING ANODE WIRE SHALL BE CONNECTED TO THE IDENTIFIED (OR BOTTOM) TERMINAL ON ALL ACCESS BOXES.

GROUNDING:
TRACE WIRE MUST BE PROPERLY GROUNDED AT ALL DEAD-ENDS/STUBS.

GROUNDING OF TRACE WIRE SHALL BE ACHIEVED BY USE OF COPPERHEAD INDUSTRIES, LLC, ANO-1005, OR APPROVED EQUAL, WITH A MINIMUM OF 20 FEET OF #14 RED HDPE INSULATED COPPER CLAD STEEL WIRE CONNECTED TO ANODE (MINIMUM 0.5 LB.) SPECIFICALLY MANUFACTURED FOR THIS PURPOSE, AND BURIED AT THE SAME ELEVATION AS THE UTILITY.

WHEN GROUNDING THE TRACE WIRE AT DEAD-ENDS/STUBS, THE GROUNDING ANODE SHALL BE INSTALLED IN A DIRECTION 180 DEGREES OPPOSITE OF THE TRACE WIRE, AT THE MAXIMUM POSSIBLE DISTANCE.

WHEN GROUNDING THE TRACE WIRE IN AREAS WHERE THE TRACE WIRE IS CONTINUOUS AND NEITHER THE MAINLINE TRACE WIRE OR THE GROUNDING ANODE WIRE WILL BE TERMINATED AT/ABOVE GRADE, INSTALL GROUNDING ANODE DIRECTLY BENEATH AND IN-LINE WITH THE TRACE WIRE. DO NOT COIL EXCESS WIRE FROM GROUNDING ANODE. IN THIS INSTALLATION METHOD, THE GROUNDING ANODE WIRE SHALL BE TRIMMED TO AN APPROPRIATE LENGTH BEFORE CONNECTING TO TRACE WIRE WITH A MAINLINE TO LATERAL CONNECTOR.

WHERE THE ANODE WIRE WILL BE CONNECTED TO AN ACCESS BOX, A MINIMUM OF 2 FEET OF EXCESS/SLACK WIRE IS REQUIRED AFTER MEETING FINAL ELEVATION.

MATERIALS CONTINUED:

SERVICE LATERALS:
A MAINLINE TRACE WIRE MUST BE INSTALLED, WITH ALL SERVICE LATERAL TRACE WIRES PROPERLY CONNECTED TO THE MAINLINE TRACE WIRE, TO ENSURE FULL TRACING/LOCATING CAPABILITIES FROM A SINGLE CONNECTION POINT.

TRACE WIRE ON ALL WATER SERVICE LATERALS MUST TERMINATE AT AN APPROVED ACCESS BOX COLOR CODED BLUE AND LOCATED DIRECTLY ABOVE THE SERVICE LATERAL AT THE EDGE OF THE ROAD RIGHT-OF-WAY.

ALL CONDUCTIVE AND NON-CONDUCTIVE SERVICE LINES SHALL INCLUDE TRACE WIRE.

SERVICE LATERALS ON PUBLIC PROPERTY:
TRACE WIRE MUST TERMINATE AT AN APPROVED GRADE LEVEL/IN-GROUND ACCESS BOX, LOCATED AT THE EDGE OF THE ROAD RIGHT-OF-WAY, AND OUT OF THE ROADWAY.

SERVICE LATERALS ON PRIVATE PROPERTY:
TRACE WIRE MUST TERMINATE AT AN APPROVED ABOVE GROUND ACCESS BOX, AFFIXED TO THE BUILDING EXTERIOR DIRECTLY ABOVE WHERE THE UTILITY ENTERS THE BUILDING, AT AN ELEVATION NOT GREATER THAN 5 VERTICAL FEET ABOVE THE FINISHED GRADE, OR TERMINATE AT AN APPROVED GRADE LEVEL/IN-GROUND ACCESS BOX, LOCATED 2 LINEAR FEET OF THE BUILDING BEING SERVED BY THE UTILITY.

LONG-RUNS, IN EXCESS OF 500 LINEAR FEET WITHOUT SERVICE LATERALS OR HYDRANTS:
TRACE WIRE ACCESS MUST BE PROVIDED UTILIZING AN APPROVED GRADE LEVEL/IN-GROUND ACCESS BOX, LOCATED AT THE EDGE OF THE ROAD RIGHT-OF-WAY, AND OUT OF THE ROADWAY. THE GRADE LEVEL/IN-GROUND ACCESS BOX SHALL BE DELINEATED USING A MINIMUM 48" POLYETHYLENE MARKER POST, COLOR CODED PER AWWA STANDARD FOR THE SPECIFIC UTILITY.

TESTING:
ALL NEW TRACE WIRE INSTALLATIONS SHALL BE LOCATED USING TYPICAL LOW FREQUENCY (512HZ) LINE TRACING EQUIPMENT, WITNESSED BY THE CONTRACTOR, ENGINEER AND FACILITY OWNER AS APPLICABLE, PRIOR TO ACCEPTANCE OF OWNERSHIP.

THIS VERIFICATION SHALL BE PERFORMED UPON COMPLETION OF ROUGH GRADING AND AGAIN PRIOR TO FINAL ACCEPTANCE OF THE PROJECT.

CONTINUITY TESTING IN LIEU OF ACTUAL LINE TRACING SHALL NOT BE ACCEPTED.

DATE: _____ USERNAME: _____ FILES

CITY OF HEATH
John Miller
DIRECTOR OF UTILITIES

DATE
10-2005
02-2012
02-2015
03-2022

STANDARD CONSTRUCTION DRAWING
WATER WORK SPECIFICATIONS & NOTES

NUMBER
WA-0

1 / 2

W01 - WATER LINE DEPTH

WATER LINES SHALL BE LAID WITH A MINIMUM OF 4'-6" DEPTH FROM THE TOP OF FINISHED GRADE (CURB) TO THE TOP OF THE WATER LINE.

W02 - BACKFILL

ALL TRENCH BACKFILL SHALL BE COMPACTED BACKFILL AS PER ODOT ITEM 611.06. THE COST OF ALL COMPACTED BACKFILL SHALL BE INCLUDED IN THE PRICE BID FOR FURNISHING AND INSTALLING PIPE.

UNLESS STATED SPECIFICALLY IN THE CONSTRUCTION DRAWINGS, ALL CONDUIT SHALL BE INSTALLED AS TYPE C. THERE MAY BE AREAS ON THE PLANS WITH THE LIMITS INDICATED ON THE PROFILE VIEW OF THE SEWER AS "COMPACTED GRANULAR BACKFILL". WITHIN THESE LIMITS THE BACKFILL SHALL BE PER TYPE A & B, EXCEPT THE STRUCTURAL FILL SHALL EXTEND FROM THE TRENCH BOTTOM TO THE SUBGRADE.

W03 - FIRE HYDRANTS

FIRE HYDRANTS SHALL BE AMERICAN AVK 2780 OR APPROVED EQUAL WITH A 6" GATE VALVE.

TRACE WIRE MUST TERMINATE AT AN APPROVED ABOVE-GROUND TRACE WIRE ACCESS BOX AND SHALL BE LOCATED BY THE WATCH VALVE (SHALL NOT BE FASTENED TO HYDRANT). (AFFIXING WITH TAPE OR PLASTIC TIES SHALL NOT BE ACCEPTABLE)

PUBLIC

THE HYDRANT GATE VALVE BOX LID SHALL BE PAINTED RED WITH TWO COATS OF RUST INHIBITIVE PAINT. THE FIRE HYDRANT ASSEMBLY SHALL BE PAINTED WITH TWO COATS OF FEDERAL SAFETY YELLOW, SHERWIN WILLIAMS HYDRANT YELLOW B55T804, BE EQUIPPED WITH STORTZ FITTINGS AND REFLECTIVE BEADS ADDED TO PAINTED ON WEATHER CAP.

PRIVATE

THE HYDRANT GATE VALVE BOX LID SHALL BE PAINTED RED WITH TWO COATS OF RUST INHIBITIVE PAINT. THE FIRE HYDRANT ASSEMBLY SHALL BE PAINTED RED WITH TWO COATS OF RUST INHIBITIVE PAINT AND BE EQUIPPED WITH STORTZ FITTINGS.

RAISED PAVEMENT MARKING

A BLUE RAISED PAVEMENT MARKER SHALL BE PLACED IN THE CENTER OF PAVEMENT DIRECTLY IN FRONT OF FIRE HYDRANTS.

W04 - WATER MAIN PROTECTION

LOCATION, SUPPORT, PROTECTION AND RESTORATION OF ALL WATER LINES, SERVICES AND APPURTENANCES SHALL BE THE RESPONSIBILITY OF THE CONTRACTOR. THE CONTRACTOR SHALL SUBMIT HIS DETAILS AND METHODS OF SUPPORTING THE WATER LINES ACROSS THE SEWER TRENCH TO THE ENGINEER FOR APPROVAL BY THE WATER DEPARTMENT. SUPPORT METHOD AND DETAIL APPROVAL SHALL BE SECURED PRIOR TO THE COMMENCEMENT OF EXCAVATION OPERATIONS.

W05 - CUSTOMER NOTIFICATION

THE CONTRACTOR SHALL NOTIFY ALL WATER CUSTOMERS AFFECTED BY THE PROPOSED WORK SEVENTY-TWO (72) HOURS IN ADVANCE OF THE APPROXIMATE TIME AND DURATION THEY SHALL BE WITHOUT WATER SERVICE.

W06 - WATERLINE CONNECTIONS

THE CONTRACTOR SHALL CONNECT ALL EXISTING MAINS, SERVICE LINES, SERVICE LINES, ETC. TO THE PROPOSED LINE. THE CONNECTION OF EXISTING WATERLINES AND SERVICES TO PROPOSED WATERLINES SHALL BE DONE IN A MANNER THAT WILL CAUSE A MINIMUM OF INCONVENIENCE TO THOSE WITH AFFECTED SERVICES. WORK CONCERNING THE DISCONNECTION AND RECONNECTION OF EXISTING WATERLINES SHALL BE DONE BETWEEN THE HOURS OF 9:00 A.M. AND 3:00 P.M., OR AS DIRECTED BY THE ENGINEER. NO SUCH WORK SHALL BEGIN UNTIL THE CITY ENGINEER, THE HEATH FIRE DEPARTMENT, THE CITY OF HEATH, AND THE RESIDENTS WHOSE SERVICES WILL BE AFFECTED ARE ALL NOTIFIED OF THE EXTENT, NATURE, AND TIME OF ANTICIPATED WORK AND THE METHOD AND SCHEDULE OF SUCH WORK HAS BEEN APPROVED BY THE CITY OF HEATH.

W07 - WATERLINE PROFILE

THE LOCATION OF ALL EXISTING UTILITIES SHOWN ON THE PROFILES IS APPROXIMATE.

W08 - WATER MAIN AND SERVICE LOCATION

ALL EXISTING WATER MAINS SHOWN ON THE PLANS WERE OBTAINED BY DILIGENT SEARCHES OF EXISTING RECORDS AND FIELD OBSERVATIONS. LOCATIONS AND ELEVATIONS ARE APPROXIMATE ONLY. ALL INDIVIDUAL SERVICE LINES MAY NOT BE SHOWN AND SHOULD BE LOCATED BY THE CONTRACTOR PRIOR TO EXCAVATION.

W09 - CONSTRUCTION PROCEDURE

TIME OF ALL WATER MAIN SHUT DOWNS SHALL BE DETERMINED BY THE DIVISION OF WATER. WHERE FEASIBLE, THE RELOCATED LINES SHALL BE LAID TO THE NEW LINE AND GRADE, TESTED AND DISINFECTED PRIOR TO SHUTTING DOWN ANY EXISTING WATER MAIN. THE CONNECTIONS OF THE RELOCATED LINE TO THE EXISTING MAIN SHALL BE DONE AT A TIME AS APPROVED BY THE WATER DEPARTMENT. ALL OPERATION OF EXISTING WATER MAIN VALVES SHALL BE DONE BY THE WATER DEPARTMENT AND NOT THE CONTRACTOR.

W10 - SERVICE DURING RELOCATION

AT ALL LOCATIONS WHERE THE EXISTING WATERLINE IS TO BE RELOCATED, ALL EXISTING SERVICE TAPS SHALL REMAIN IN SERVICE AT ALL TIMES. A TEMPORARY WATERLINE SHALL BE INSTALLED DURING THE CONSTRUCTION OF THE PROPOSED NEW WATERLINE.

W11 - WATERLINE TESTING AND DISINFECTION

ALL WATERLINES SHALL BE PRESSURE TESTED AT 150 PSI FOR 2 HOURS PRIOR TO ACCEPTANCE BY THE CITY OF HEATH. THE COST OF THE ABOVE WILL BE INCLUDED IN THE UNIT PRICE BID FOR THE WATER MAIN. THIS TESTING MUST BE IN ACCORDANCE WITH THE LATEST VERSION OF AWWA C-600.

ANY TESTING PERFORMED AGAINST EXISTING VALVES SHALL BE DONE AT THE CONTRACTOR'S RISK AND IN STRICT COMPLIANCE WITH THE REQUIREMENTS OF THE ENGINEER. IF SATISFACTORY TEST RESULTS CANNOT BE OBTAINED AGAINST AN EXISTING VALVE, THE NEW LINE SHALL BE DISCONNECTED FROM THE EXISTING LINE, PLUGGED AND RE-TESTED. DAMAGE CAUSED TO EXISTING LINES AND VALVES SHALL BE REPAIRED BY THE CONTRACTOR AT HIS OWN EXPENSE. IF THERE ARE INDICATIONS OF LEAKS UNDER THIS PRESSURE TEST, THE CONTRACTOR SHALL LOCATE AND REPAIR THEM AT HIS COST AND EXPENSE UNTIL THE LEAKAGE IS WITHIN THE SPECIFIED ALLOWANCE. ALL BENDS AND JOINT DEFLECTIONS SHALL HAVE CONCRETE BACKING. ALL ALL VALVES SHALL HAVE SUPPORTS AND BE IN ACCORDANCE WITH STANDARD DRAWINGS.

W11 - WATERLINE TESTING AND DISINFECTION CONTINUED

BEFORE BEING PLACED INTO SERVICE AND AFTER HYDROSTATIC TESTING, THE COMPLETED WATER WORK SHALL BE DISINFECTED IN ACCORDANCE WITH THE SPECIFICATIONS AND PROCEDURES OUTLINED IN THE LATEST VERSION OF AWWA C651 "STANDARD PROCEDURE FOR DISINFECTING WATER MAINS". ALL BACTERIOLOGICAL TESTING SHALL BE PERFORMED IN THE PRESENCE OF THE CITY. SHOULD THE INITIAL TREATMENT RESULT IN AN UNSATISFACTORY BACTERIAL TEST, THE ORIGINAL CHLORINATION PROCEDURE SHALL BE REPEATED BY THE CONTRACTOR AT HIS EXPENSE UNTIL SATISFACTORY RESULTS ARE OBTAINED.

THE CONTRACTOR SHALL HAND SWAB ALL PIPE AND FITTINGS THAT ARE NOT OTHERWISE DISINFECTED. THE AMOUNT OF CHLORINE TO BE USED DURING HAND SWABBING OPERATIONS WILL BE DETERMINED BY THE DIVISION OF WATER.

W12 - CROSSINGS AND CONNECTIONS TO EXISTING PIPES AND UTILITIES

WHERE PLANS PROVIDE FOR A PROPOSED WATERLINE TO BE CONNECTED TO, OR CROSS OVER OR UNDER AN EXISTING SEWER OR UNDERGROUND UTILITY, THE CONTRACTOR SHALL LOCATE THE EXISTING PIPES OR UTILITIES BOTH AS TO LINE AND GRADE BEFORE STARTING TO LAY THE PROPOSED WATERLINE.

IF IT IS DETERMINED THAT THE PROPOSED WATERLINE WILL INTERSECT A UTILITY IF CONSTRUCTED AS SHOWN ON THE PLAN OR ELEVATION DIFFERENCE WHEN CONNECTING NEW WATERLINE TO EXISTING WATERLINE, THE ENGINEER SHALL BE NOTIFIED BEFORE STARTING CONSTRUCTION OF ANY PORTION OF THE PROPOSED WATERLINE WHICH WOULD BE AFFECTED BY THE INTERFERENCE WITH AN EXISTING UTILITY.

W13 - INSTALLATION AND CONFLICTS

ALL WATER LINES SHALL BE INSTALLED WITH AT LEAST 10 FEET HORIZONTAL SEPARATION FROM SANITARY SEWER AND STORM SEWER LINES. WHENEVER A WATER LINE AND SEWER MUST CROSS, THE SEWER MAIN (STORM OR SANITARY) SHALL BE LAID SUCH THAT THE CROWN OF THE SEWER IS AT LEAST 18 INCHES BELOW THE INVERT OF THE WATER LINE MEASURED BETWEEN THE OUTSIDE PIPE WALLS. IN CASES WHERE THE REQUIRED SEPARATION CANNOT BE MAINTAINED, CLOSER INSTALLATION MAY BE PERMITTED ON A CASE-BY-CASE BASIS ONLY AFTER RECEIPT OF WRITTEN CONCURRENCE FROM THE OHIO EPA DIVISION OF DRINKING WATER. 2003 RECOMMENDED STANDARDS FOR WATER WORKS, SECTIONS 8.8.2 AND 8.8.3 SHALL GOVERN AS TO THE SEPARATION OF WATER LINE FROM CONTAMINATION SOURCES.

W14 - VALVE EXTENSION

IF THE TOP OF THE OPERATING NUT IS LOWER THAN 36 INCHES BELOW FINISHED GRADE, AN EXTENSION STEM SHALL BE FURNISHED TO BRING THE TOP OF THE OPERATING NUT TO BETWEEN 24 INCHES AND 36 INCHES OF FINISHED GRADE ELEVATION.

W15 - SERVICE CONNECTIONS

NO SERVICE CONNECTIONS SHALL BE MADE TO THE PUBLIC WATER SYSTEM WHERE A PROPERTY HAS A CROSS-CONNECTION TO AN AUXILIARY WATER SYSTEM. OWNER WILL INSPECT SERVICE LINES PRIOR TO PROVIDING SERVICE.

W16 - INDIVIDUAL BOOSTER PUMPS

NO INDIVIDUAL BOOSTER PUMPS SHALL BE PLACED ON SERVICE CONNECTIONS WHICH ARE SUPPLIED BY THE MAIN PUBLIC SYSTEM. OWNER WILL INSPECT SERVICE LINES PRIOR TO PROVIDING SERVICE.

W17 - MINIMUM PRESSURE

A MINIMUM WATER PRESSURE OF 35 PSI SHALL BE MAINTAINED AT ALL SERVICE TAP LOCATIONS. A MINIMUM WATER PRESSURE OF 20 PSI SHALL BE MAINTAINED AT ALL POINTS OF THE SYSTEM.

W18 - FLUSHING OF NEW LINE

CONTRACTOR SHALL COORDINATE ALL FLUSHING OPERATIONS WITH OWNER. HIGH FLOW RATE MAY RESULT IN LOW PRESSURE THROUGH THE SYSTEM.

W19 - CONCRETE COLLAR

CONTRACTOR SHALL REFER TO HEATH STANDARD CONSTRUCTION DRAWING WA-3 FOR CONCRETE COLLARS TO BE PLACED AROUND VALVE BOXES.

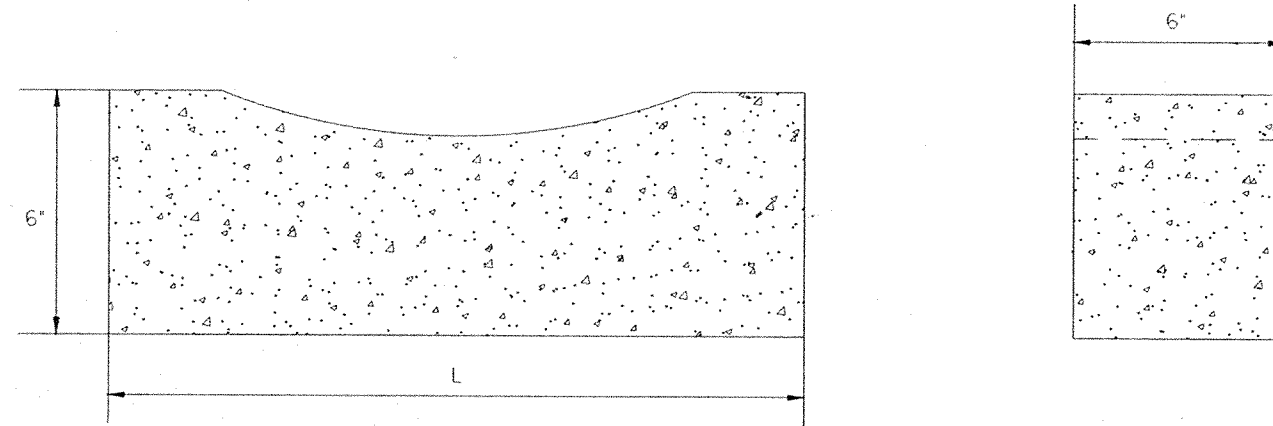

	SIZE OF VALVE	L	VOLUME CU. - FT.
VALVES	3"	15"	0.31
	4"	16"	0.33
	6"	17"	0.36
	8"	20"	0.42
BUTTERFLY VALVES	12"	24"	0.50
	16"	30"	0.63
	20"	36"	0.75
	24"	42"	0.88
	30"	48"	1.00

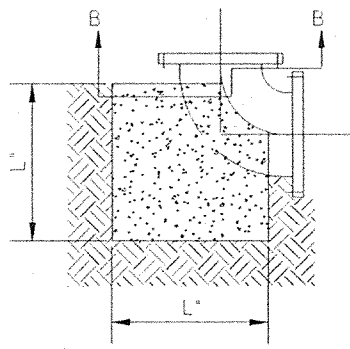

90° BENDS

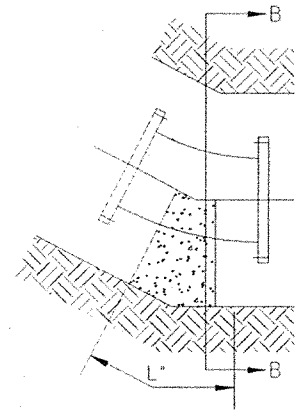

BENDS LESS THAN 90°

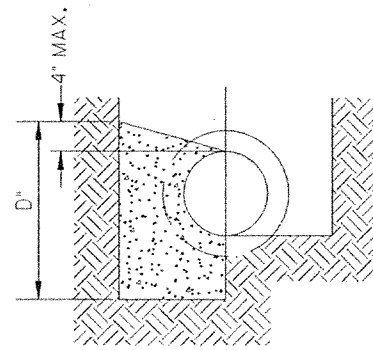

SECTION B-B

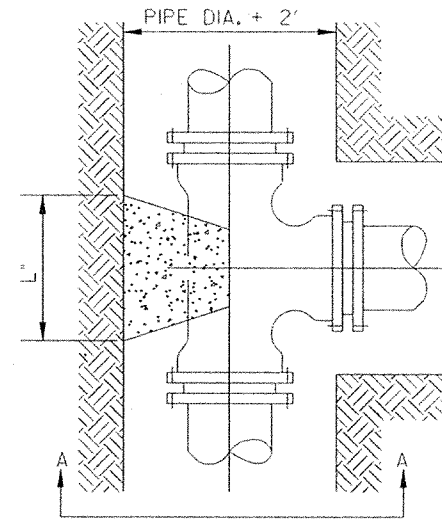

SECTION A-A

NOTES:

1. BACKER DESIGNED FOR 3000 PSF SOIL BEARING.
2. CONCRETE TO BE PLACED AGAINST UNDISTURBED EARTH.
3. PROVIDE CLEARANCE FOR REMOVAL OF BOLTS.
4. SEE SHEET 2 OF 2 FOR ADDITIONAL INFORMATION.

SIZE OF PIPE	DEGREE OF BEND											
	11 1/4°			22 1/2°			45°			90°		
	L"	D"	V c.f.	L"	D"	V c.f.	L"	D"	V c.f.	L"	D"	V c.f.
3"	4	3	0.1	6	4	0.2	10	4	0.3	10	4	0.3
4"	5	4	0.2	9	5	0.4	14	5	0.6	14	5	0.6
6"	8	6	0.5	12	7	0.7	20	8	1.4	18	9	1.7
8"	9	8	0.7	16	9	1.4	24	12	2.7	25	11	4.0
12"	14	12	1.8	24	14	3.6	36	18	6.8	32	18	10.7
16"	18	16	3.4	32	18	6.7	36	32	13.4	41	26	25.4
20"	25	20	6.4	30	30	11.5	49	36	20.5	50	32	46.5
24"	27	24	9.0	39	34	18.4	60	42	35.0	58	40	77.7

STEEL WILL BE USED AS REQUIRED BY ENGINEER

R U N	BRANCH																							
	3"			4"			6"			8"			12"			16"			20"			24"		
	L"	D"	V c.f.	L"	D"	V c.f.	L"	D"	V c.f.	L"	D"	V c.f.	L"	D"	V c.f.	L"	D"	V c.f.	L"	D"	V c.f.	L"	D"	V c.f.
3"	12	5	0.5																					
4"	10	6	0.5	11	8	0.8																		
6"	9	7	0.5	11	8	0.8	18	12	1.9															
8"	8	8	0.5	10	9	0.7	18	12	1.9	23	16	3.5												
12"	6	12	0.6	8	12	0.8	18	12	1.9	23	16	3.5	38	22	8.7									
16"	6	16	0.8	6	16	0.8	14	16	2.0	20	18	3.3	36	23	8.7	49	30	13.6						
20"	6	20	1.0	6	20	1.0	11	20	1.9	18	20	3.3	35	24	8.7	46	32	13.6	60	38	26.5			
24"	6	24	1.2	6	24	1.2	9	24	1.9	15	24	3.3	30	28	8.7	42	36	14.0	54	42	26.3	68	48	45.4

STEEL WILL BE USED AS REQUIRED BY ENGINEER

8/10/2005 11:12:03 AM M:\CH2005-03 Development\Revs\CMS & STD\Water\WA-2.dgn

CITY OF HEATH
DIRECTOR OF UTILITIES

DATE
05-1997

STANDARD CONSTRUCTION DRAWING
BACKING FOR BENDS AND TEES

NUMBER
WA-2

1 / 1

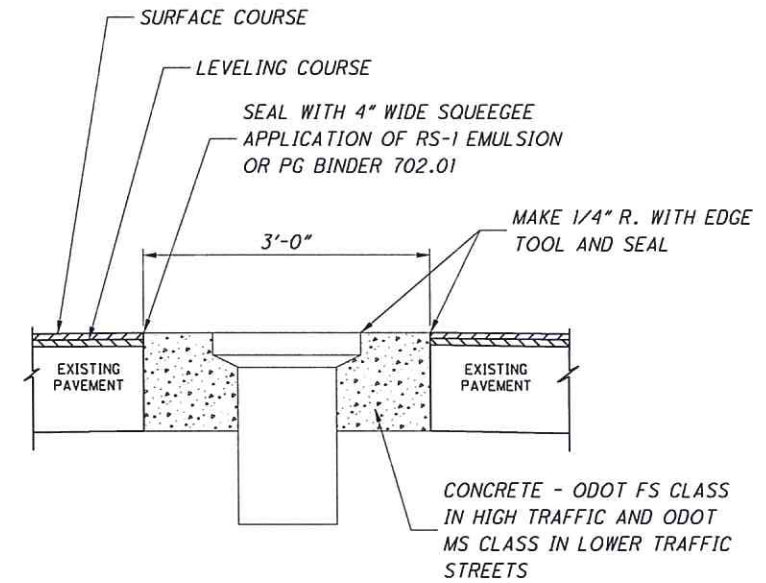
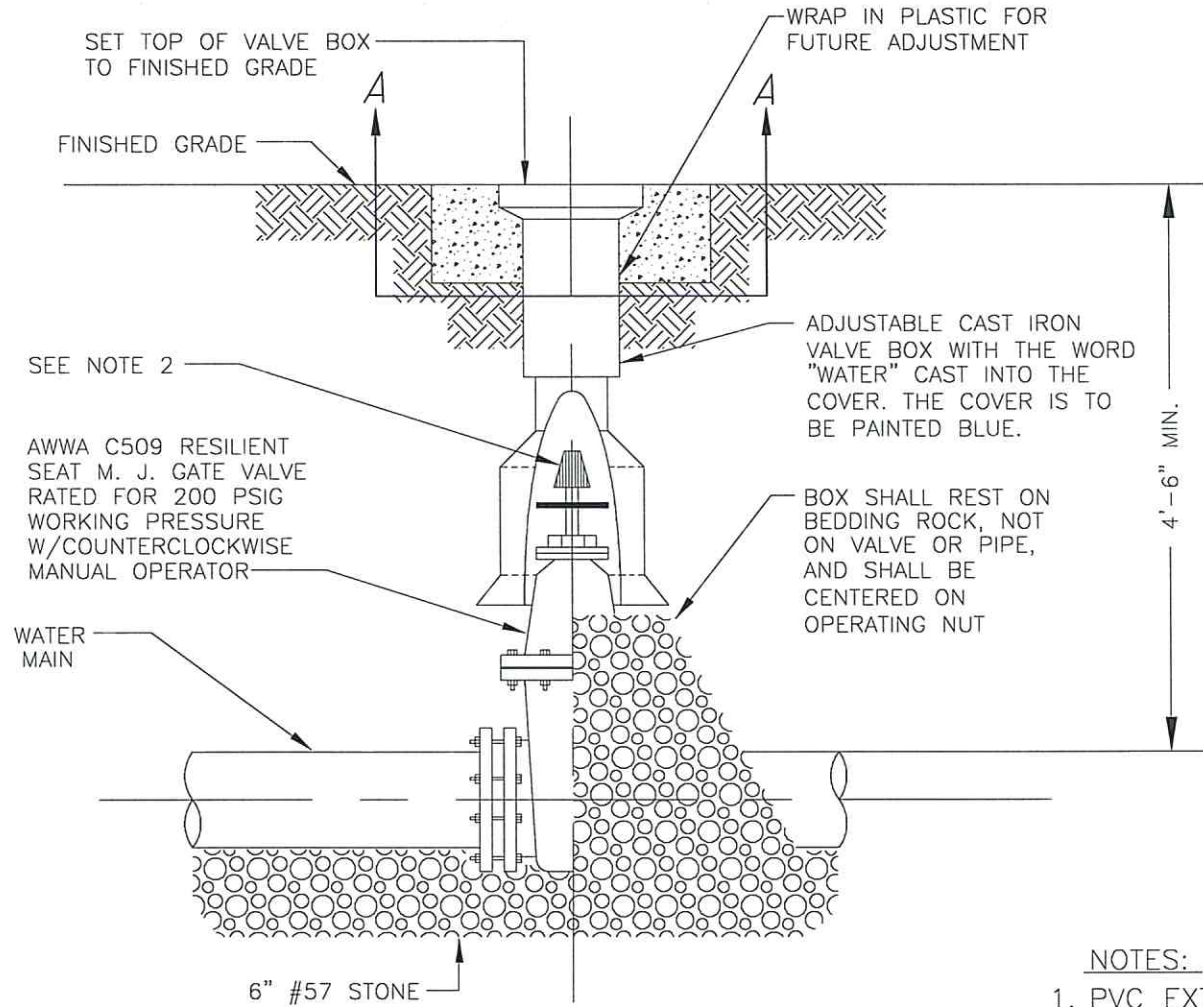

SECTION A-A

NOTES:

1. PVC EXTENSIONS SHALL NOT BE USED ON VALVE BOX INSTALLATION.
2. THE ACTUATING NUT FOR DEEPER VALVES SHALL BE EXTENDED TO A 4 FOOT DEPTH BELOW FINISHED GRADE.
3. FOR VALVES TO BE PLACED IN PAVED AREAS, AN 8" x 36" DIAMETER CONCRETE COLLAR, CLASS "C", WILL BE REQUIRED.
4. UTILITY CASTINGS WILL BE ADJUSTED TO GRADE IF THE UTILITY CASTING IS MORE THAN 1/8" (MAX) BELOW OR ABOVE THE FINISHED PAVEMENT SURFACE. THE ENGINEER SHALL MAKE A DETERMINATION OF THOSE UTILITY CASTINGS TO BE ADJUSTED AFTER THE PLACEMENT OF THE FINAL ASPHALT PAVEMENT COURSE. THE WORK SHALL BE PERFORMED IN ACCORDANCE WITH THE PERTINENT ODOT CMS SPECIFICATION.
5. CONCRETE COLLARS ARE REQUIRED TO BE CONSTRUCTED FOR ALL VALVE BOXES WITHIN THE ROADWAY THAT ARE NEWLY CONSTRUCTED, VALVE BOXES THAT ARE ADJUSTED TO GRADE, OR EXISTING VALVE BOXES WITHIN THE LIMITS OF THE PAVEMENT THAT DO NOT ALREADY HAVE A CONCRETE COLLAR.

3/2/2012 1:39:43 PM shaines M:\CH2012-03_Std_Dwg\dwg\Sheets\Water\DCNV2-12_WA-4.dgn

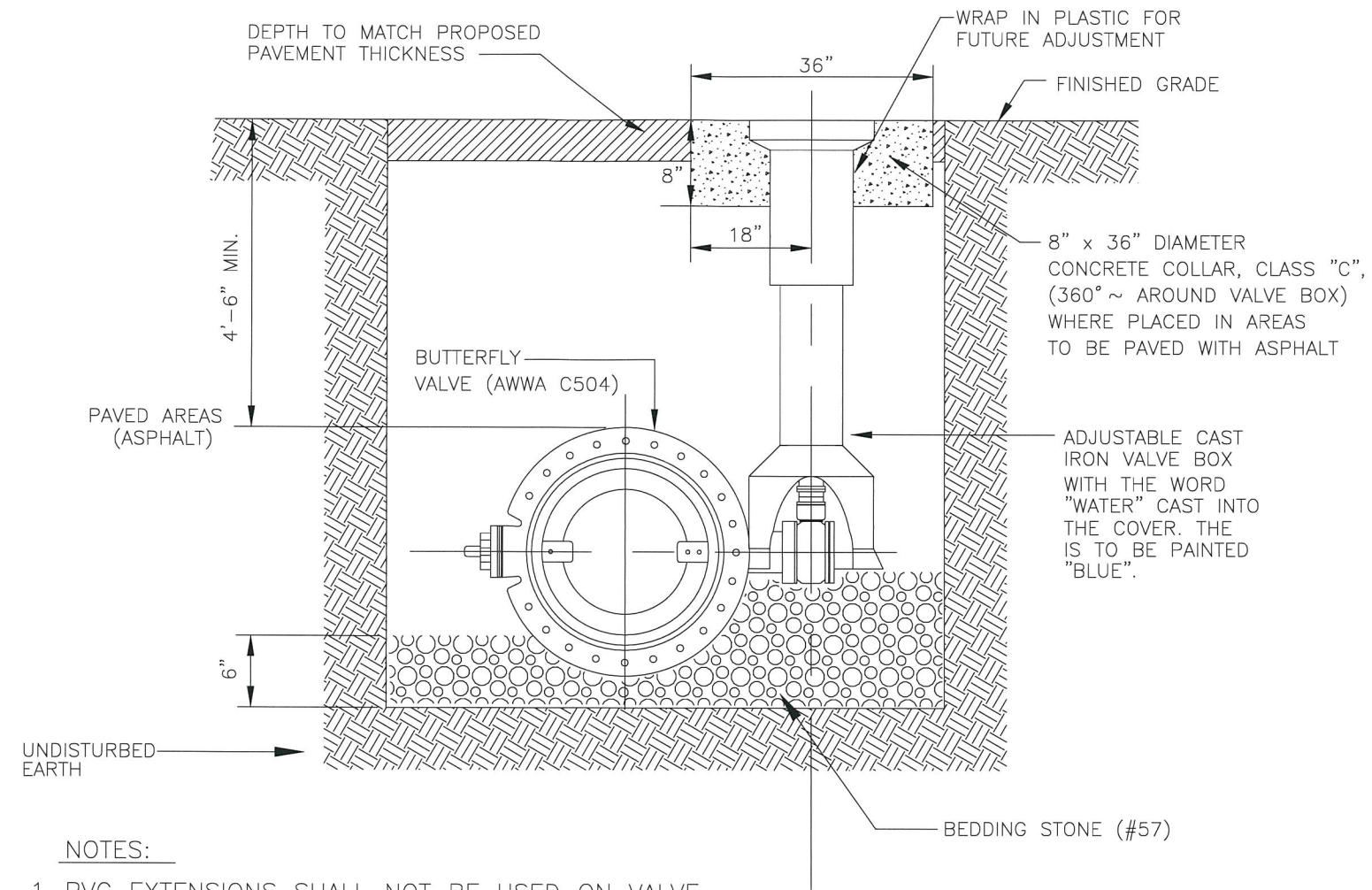

NOTES:

1. PVC EXTENSIONS SHALL NOT BE USED ON VALVE BOX INSTALLATION.
2. ALL WATER SHUT-OFF VALVES SIXTEEN (16) INCHES AND LARGER SHALL BE BUTTERFLY VALVES EQUIPPED WITH A BYPASS.

CITY OF HEATH
John J. Healy
DIRECTOR OF UTILITIES

DATE
05-1997
02-2012

STANDARD CONSTRUCTION DRAWING
BUTTERFLY VALVE WITH BOX
(FOR VALVES 16" OR LARGER)

NUMBER
WA-4

1 / 1

3/2/2012 1:40:03 PM shaines M:\CH2012-03 Std Dwg\dpn\sheet\Water\DCN\2-12_WA-5.dgn

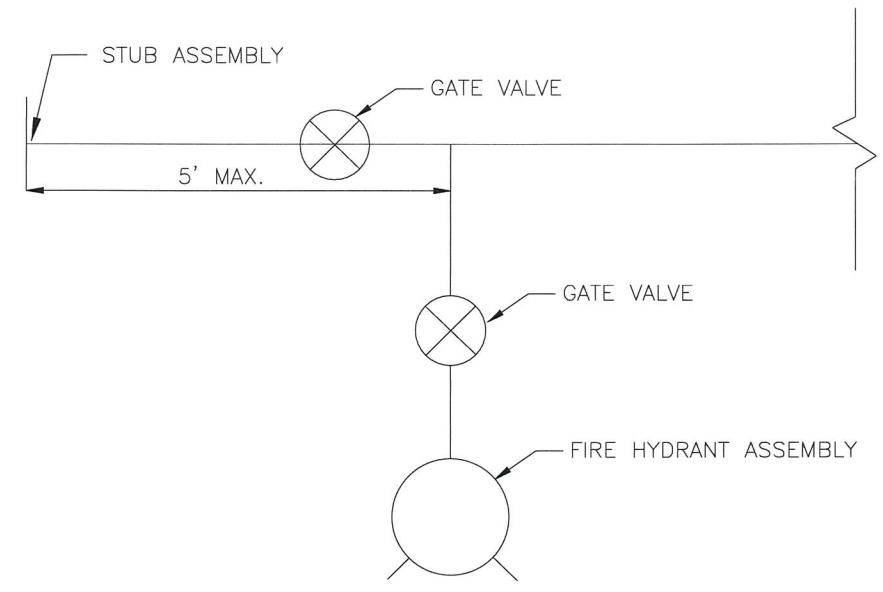
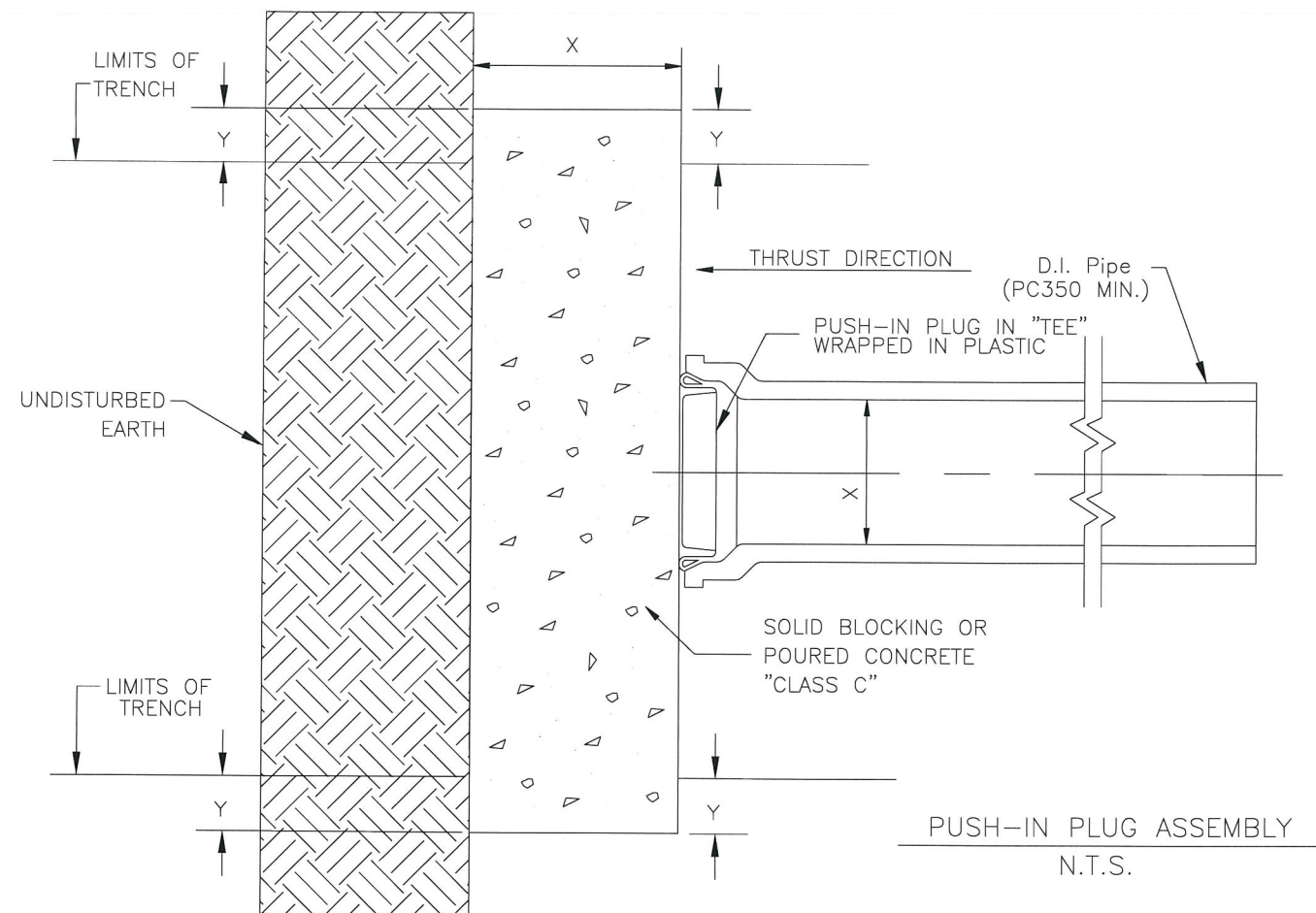

PLAN VIEW
N.T.S.

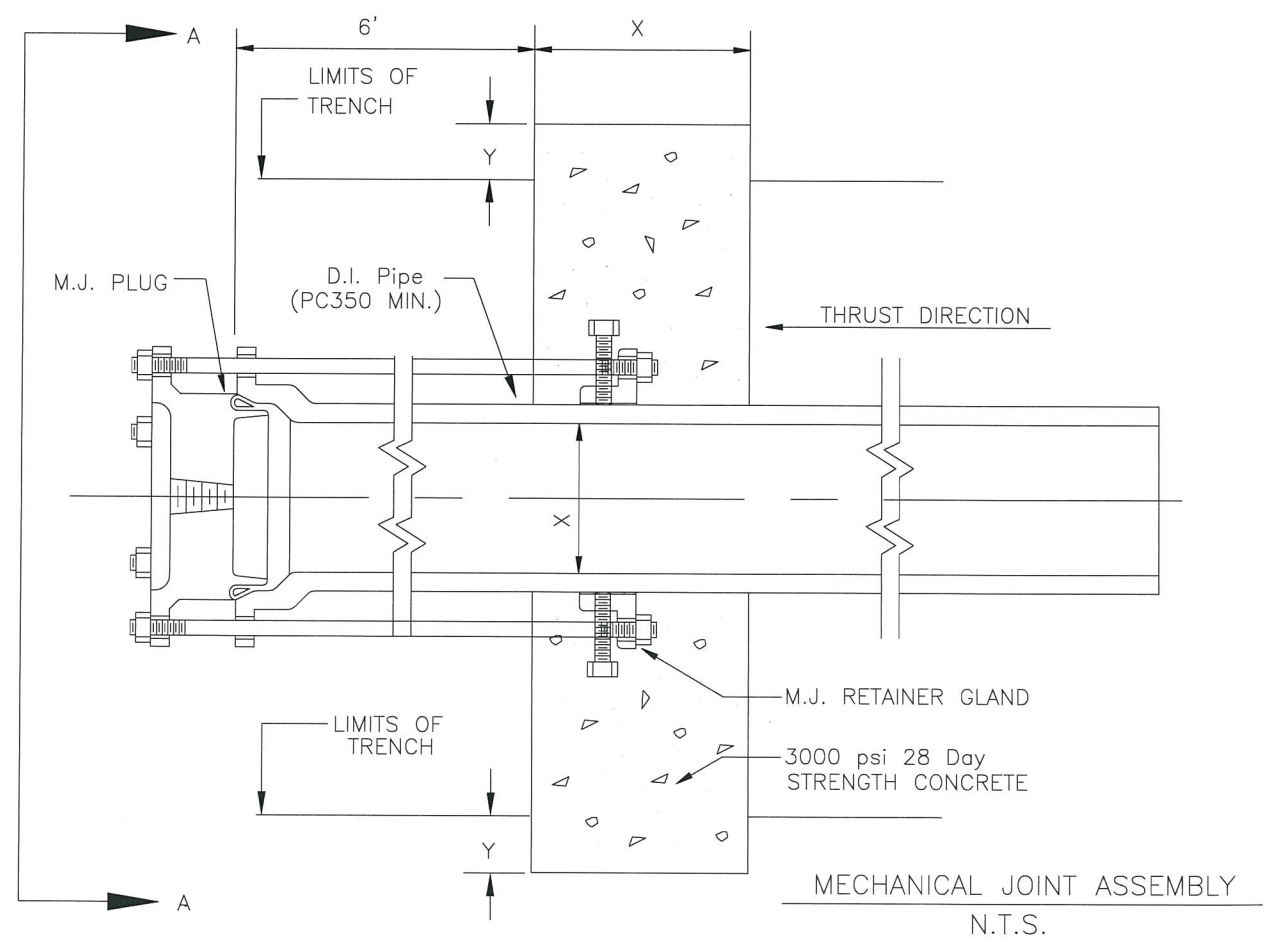

PIPE SIZE	DIMENSION
X	Y
6"	8"
8"	8"
10"	8"
12"	12"
16"	12"

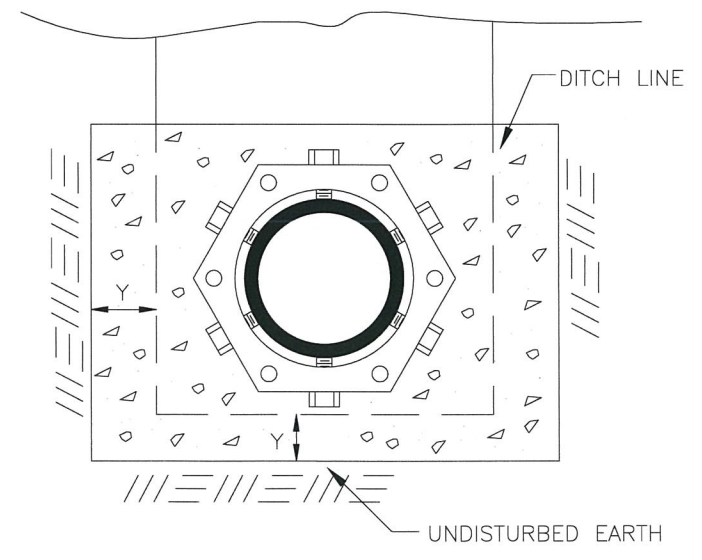

SECTION A-A
N.T.S.

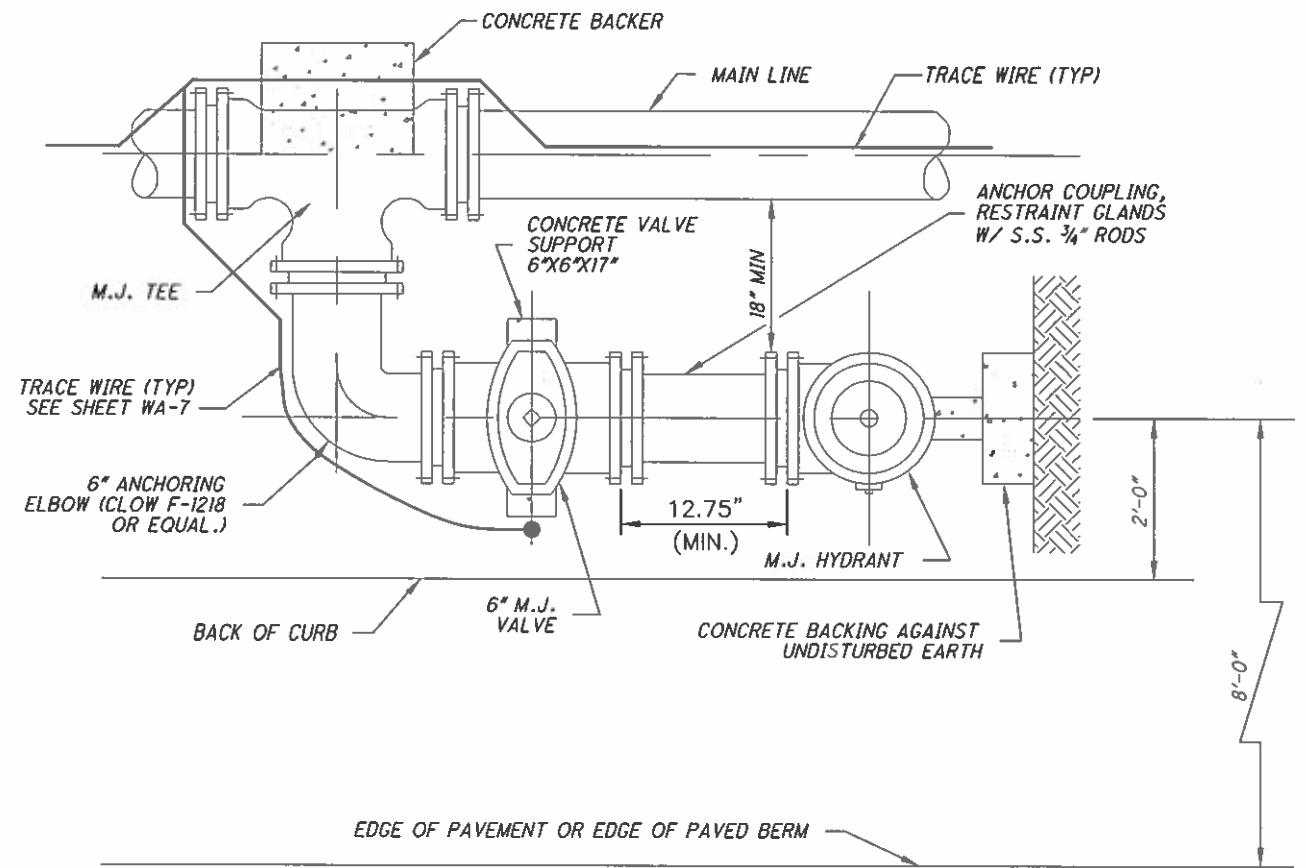

NOTES:

1. FIRE HYDRANT SHALL HAVE A MAXIMUM BURY OF 7'. MODIFICATION OF THE HYDRANT LEAD TO MEET THIS REQUIREMENT SHALL BE MADE IN THAT SECTION FROM THE VALVE TO THE HYDRANT.
2. FIRE HYDRANT SHALL BE SET A MINIMUM OF 6' FROM ALL DRIVEWAY OPENINGS.
3. CONTRACTOR SHALL INSTALL PROPER GRAVEL BACKFILL FOR WEEPHOLE DRAINAGE.
4. TRACE WIRE TO BE EXTENDED TO FIRE HYDRANT IF THE DISTANCE FROM VALVE IS GREATER THAN 10' OR ANY DEFLECTION OF PIPE FROM VALVE TO FIRE HYDRANT.

DATE: _____ TIME: _____ USERNAME: SFLES

CITY OF HEATH
 DIRECTOR OF UTILITIES

DATE
 05-1997
 02-2012
 02-2015
 03-2022

STANDARD CONSTRUCTION DRAWING
 FIRE HYDRANT ASSEMBLY - TYPE 1

NUMBER
 WA-6

1 / 1

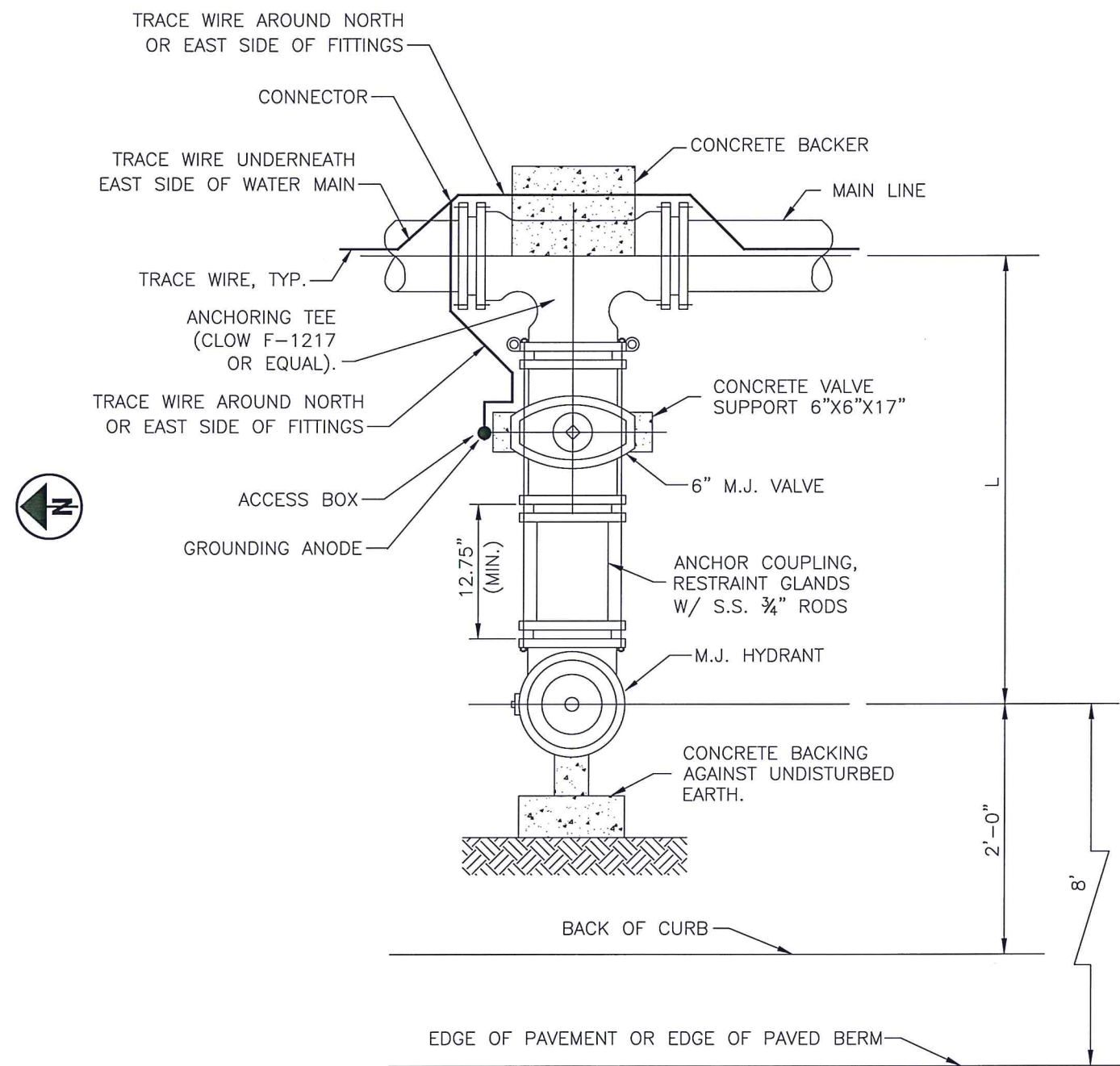

MAIN LINE	DIMENSION L (MIN.)
6"	35"
8"	36"
12"	39"
16"	42"

- NOTES:**
1. FIRE HYDRANT SHALL HAVE A MAXIMUM BURY OF 7'. MODIFICATION OF THE HYDRANT LEAD TO MEET THIS REQUIREMENT SHALL BE MADE IN THAT SECTION FROM THE VALVE TO THE HYDRANT.
 2. FIRE HYDRANT SHALL BE SET A MINIMUM OF 6' FROM ALL DRIVEWAY OPENINGS.
 3. CONTRACTOR SHALL INSTALL PROPER GRAVEL BACKFILL FOR WEEPHOLE DRAINAGE.
 4. TRACE WIRE TO BE EXTENDED TO FIRE HYDRANT IF THE DISTANCE FROM VALVE IS GREATER THAN 10' OR ANY DEFLECTION OF PIPE FROM VALVE TO FIRE HYDRANT.

8/10/2005 11:14:09 AM shaines M:\Ch2005-03 Development\Reqs\CMS & STD\Water\WA-8.dgn

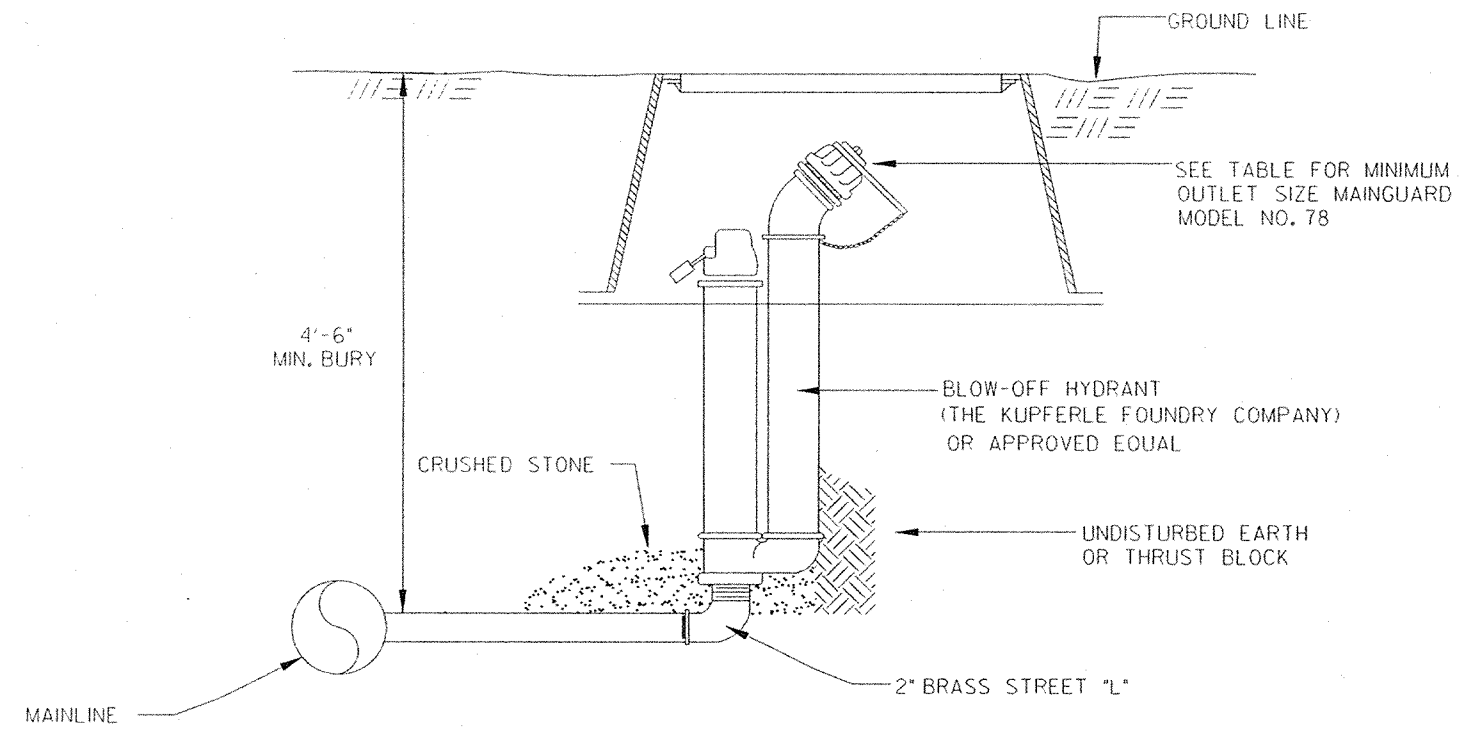

NOTES:

- 1. BLOWOFF ASSEMBLY TO BE USED AT HIGH POINTS IN THE WATER LINE AND WHERE A FIRE HYDRANT IS NOT WITHIN 100' OF SAID HIGH POINT.

CITY OF HEATH
A. Brown
DIRECTOR OF UTILITIES

DATE
05-1997

STANDARD CONSTRUCTION DRAWING
BLOW-OFF ASSEMBLY

NUMBER
WA-8

1 / 1

3/2/2012 1:41:55 PM shaines M:\CH2012-03_Sld_Dwg\dwg\sheet\Water\DCN2-12_WA-9.dgn

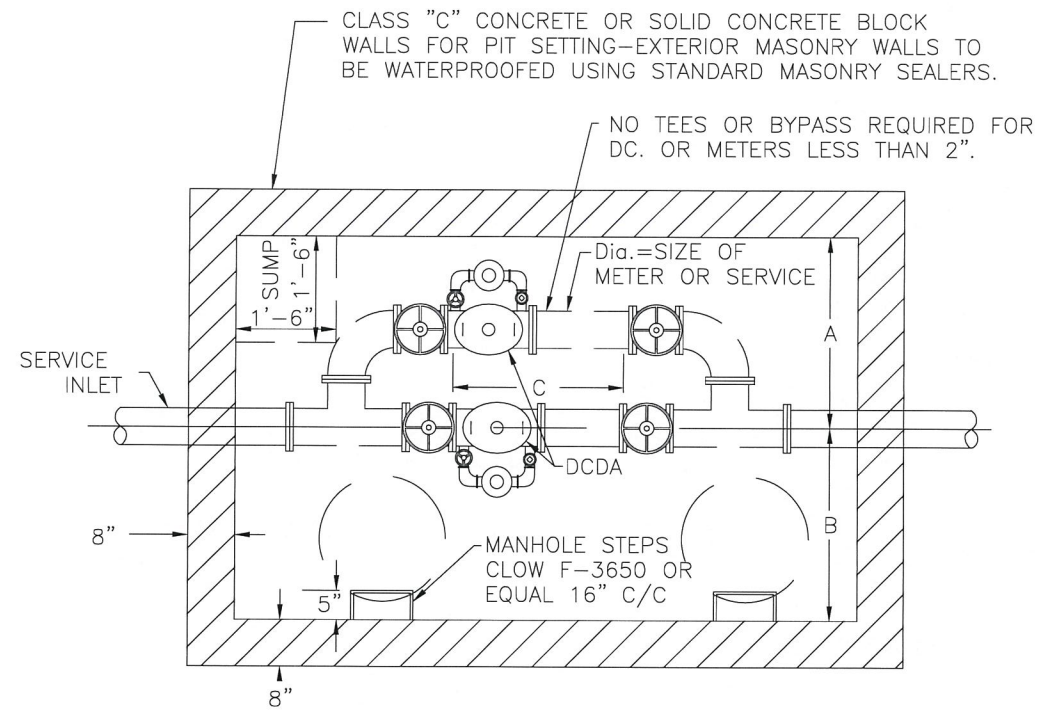

NOTES:

1. AN APPROVED PRECAST METER PIT MAY BE USED IN LIEU OF A CONSTRUCTED PIT FOR OUTSIDE SETTINGS.

* DIMENSIONS SHOWN IN THIS COLUMN ARE FACE TO FACE. ALLOWANCES MUST BE PROVIDED FOR THE THICKNESS OF THE GASKETS TO BE USED. (DIMENSIONS DO NOT APPLY TO DC SETTINGS).

SIZE MAIN METER	INSIDE VAULT DIMENSION		MIN. WALL CLEARANCE		
	LENGTH	WIDTH	A	B	C *
1 1/2"	6'-0"	4'-0"	1'-6"	2'-6"	1'-1"
2"	7'-0"	4'-0"	1'-6"	2'-6"	1'-5"
3"	8'-0"	4'-0"	1'-6"	2'-6"	2'-9"
4"	8'-0"	5'-0"	2'-0"	3'-0"	2'-9"
6"	10'-0"	6'-3"	2'-8"	3'-7"	3'-9"
8"	11'-0"	7'-3"	3'-0"	4'-3"	4'-5"
10"	14'-6"	8'-0"	3'-0"	5'-0"	5'-8"
10"X12"	14'-6"	8'-0"	3'-0"	5'-0"	5'-8"

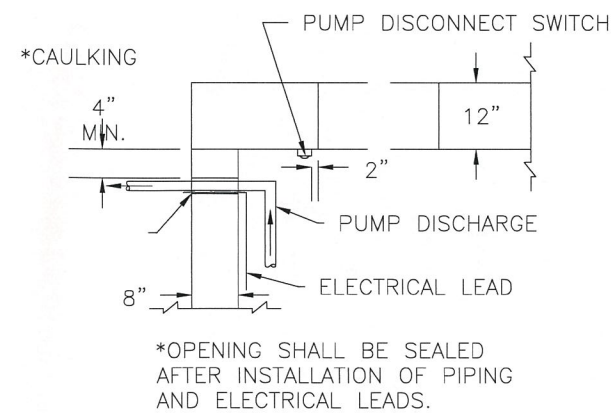
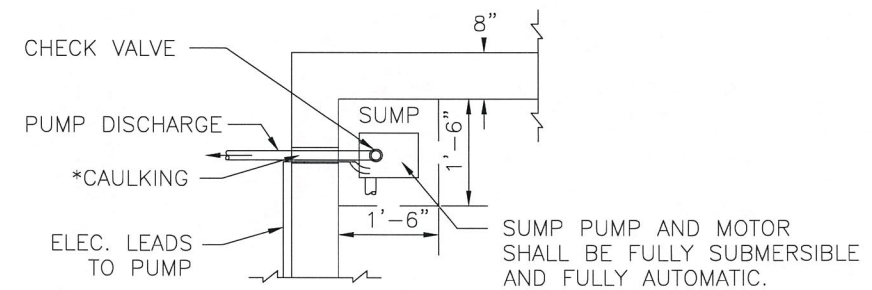
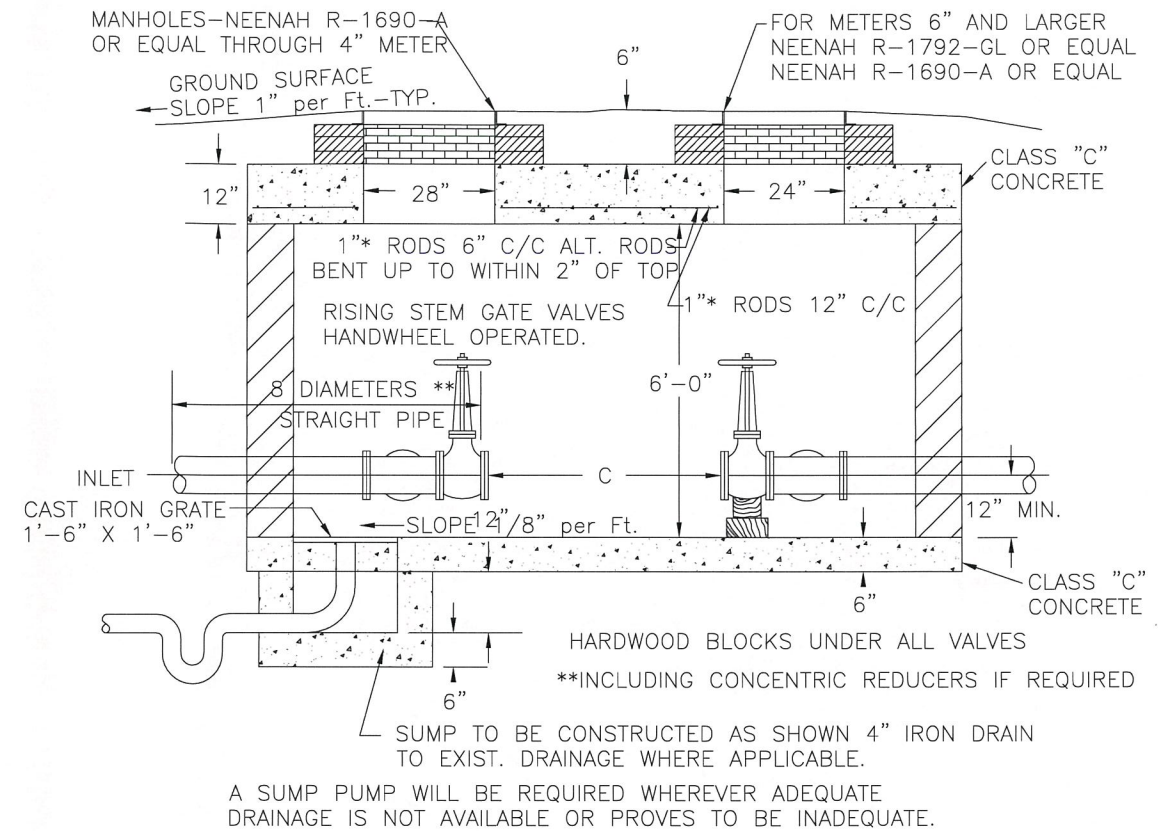

NOTES:

1. THE LENGTH AND DIRECTION OF PUMP DISCHARGE PIPE SHALL BE AS REQUIRED TO PREVENT REENTRY OF DISCHARGE INTO THE PIT.
2. PIPING OR ELECTRICAL LEADS SHALL NOT BE PLACED IN THE MANHOLE OPENING.

2/9/2015 11:16:28 AM - ltonghenry - j:\2014\14055 Health Misc\Health Std Dwgs\Water\2-15 WA-10.dgn

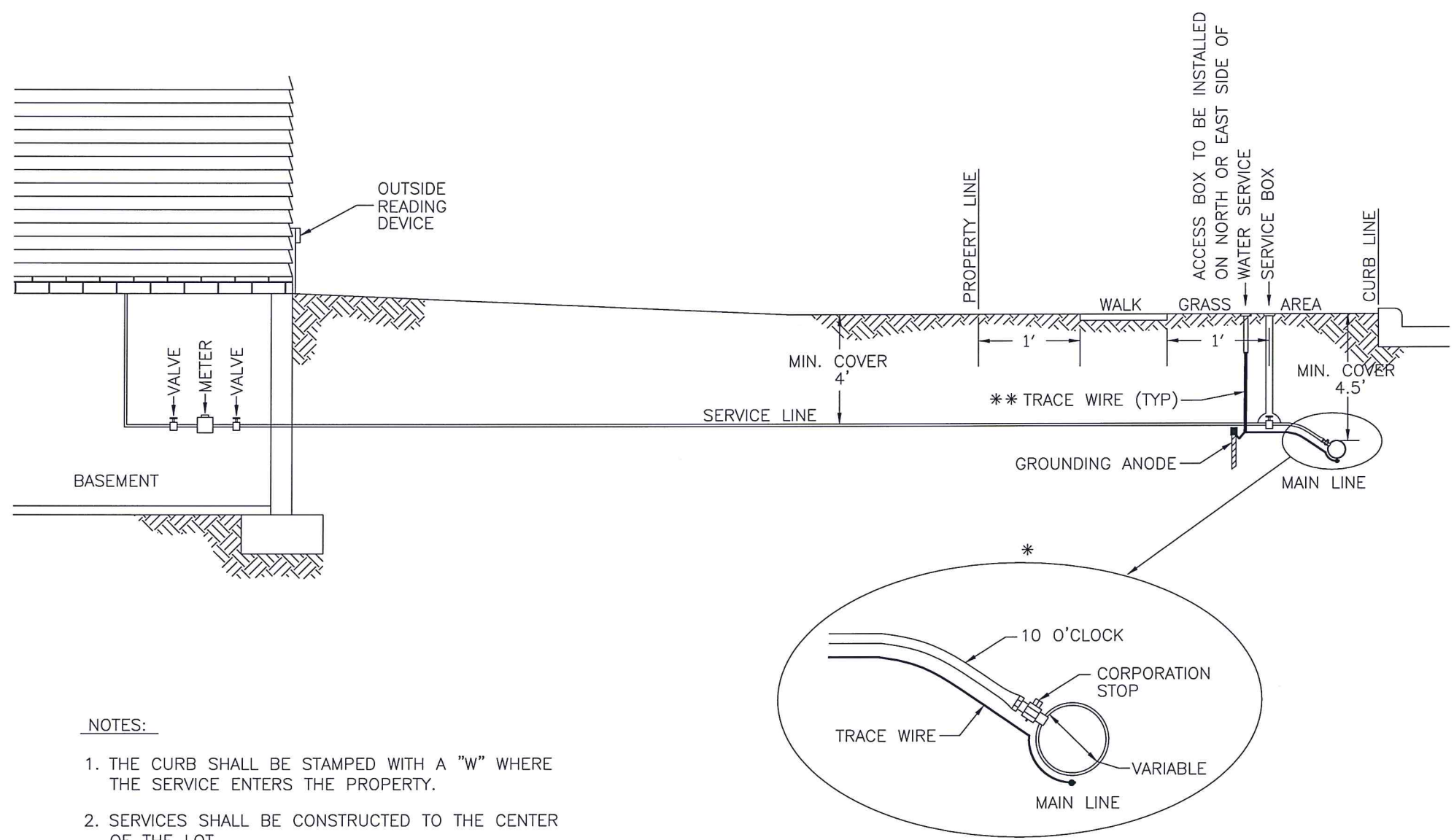

** TRACE WIRE SHOWN AWAY FROM PIPE FOR CLARITY.

NOTES:

1. THE CURB SHALL BE STAMPED WITH A "W" WHERE THE SERVICE ENTERS THE PROPERTY.
2. SERVICES SHALL BE CONSTRUCTED TO THE CENTER OF THE LOT.
3. ALL SERVICE BOXES SHALL BE VISIBLE AND PAINTED BLUE.
4. SERVICE LINE SHALL BE SOFT COPPER, TYPE K AND NOT LESS THAN 3/4" DIAMETER OR "CTS", 200 PSI, WITH STAINLESS STIFFENERS, BURIED WITH TRACE WIRE.
- * 5. NO TAPS AT 12 O'CLOCK. USE 10 O'CLOCK OR 2 O'CLOCK.
6. TRACE WIRE SHALL BE INSTALLED IMMEDIATELY ADJACENT TO THE SERVICE PIPE. THE TRACE WIRE SHALL BE FASTENED TO THE PIPE WITH DUCT TAPE OR PLASTIC TIES AT 5' INTERVALS.

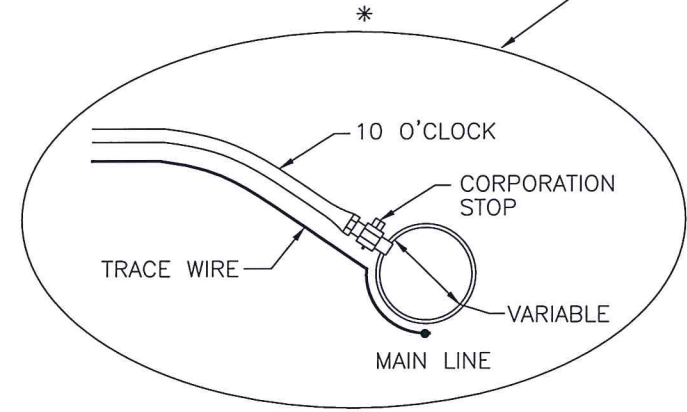

8/10/2005 11:16:03 AM shornes M:\CH2005-03 Development Regs\CMS & STD\Water\WA-11.dgn

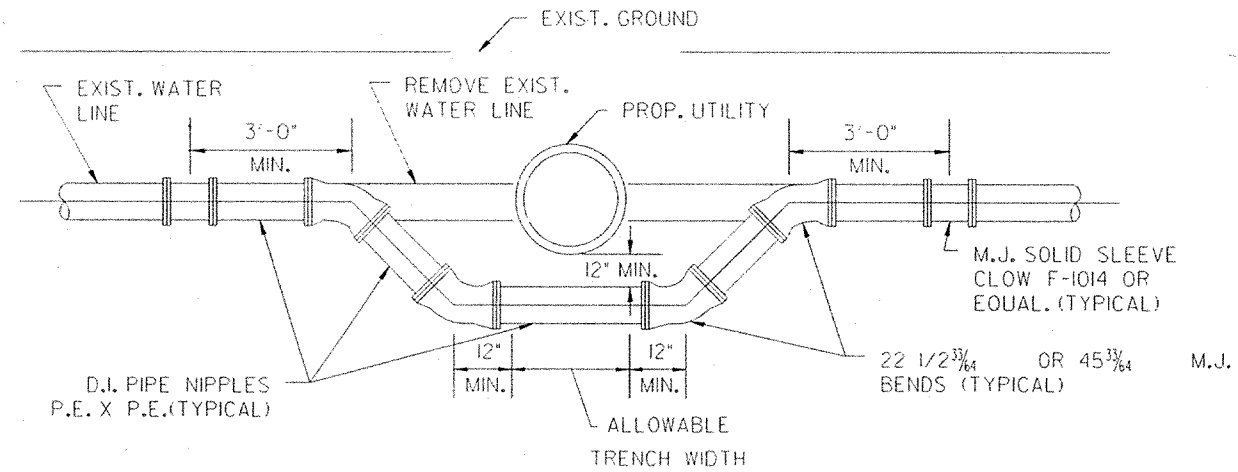

NOTES:

1. TIME AND DURATION OF SHUT DOWN SHALL BE DETERMINED BY THE DIRECTOR OF UTILITIES.
2. THE CONTRACTOR SHALL NOTIFY ALL WATER CUSTOMERS EFFECTED BY THE PROPOSED WORK AT LEAST 24 HOURS IN ADVANCE OF SHUT DOWN.
3. ALL BENDS SHALL BE SECURED BY RETAINING GLANDS, RODDING OR OTHER METHODS AS APPROVED BY THE ENGINEER TO RESTORE MAIN TO SERVICE AS SOON AS POSSIBLE. CONCRETE BACKING SHALL THEN BE PROVIDED IN ACCORDANCE WITH STANDARD DRAWING WA - 2.
4. THE RELOCATED LINES SHALL BE LAID TO THE NEW LINE AND GRADE, TESTED AND DISINFECTED PRIOR TO SHUT DOWN OF EXISTING MAIN AND CONNECTION OF THE RELOCATED LINES TO THE EXISTING MAIN.
5. ALL WATER LINES SHALL BE DISINFECTED BY SWABBING WITH A 5 PERCENT HYPOCHLORITE SOLUTION IN ACCORDANCE WITH THE APPLICABLE SECTIONS OF A.W.W.A. C-60I.

CITY OF HEATH
[Signature]
DIRECTOR OF UTILITIES

DATE
05-1997

STANDARD CONSTRUCTION DRAWING
WATERLINE LOWERING

NUMBER
WA-11

1 / 1

9/10/2005 11:16:29 AM shaines M:\CH2005-03 Development Regs\CMS & STD\Water\WA-12.dgn

SIZE WATER MAIN	MAX. BELL O.D.	MIN. SMOOTH STEEL CASING PIPE REOD.
6"	9.52"	16"
8"	11.89"	18"
12"	16.35"	24"
16"	20.84"	30"
20"	27.00"	36"
24"	31.50"	42" (B)
30"	38.14"	48" (B)
36"	45.00"	54" (B)
42"	51.25"	60" (B)
48"	58.00"	66" (B)

- (A) CASING PIPE SIZE BASED ON LARGEST BELL O.D. OF D.I. PIPE MANUFACTURED AND NOMINAL CONCRETE PIPE SIZE.
- (B) CASING PIPE MUST BE 6" (MIN.) LARGER THAN SIZE SHOWN WHEN TUNNEL LINER PLATE OR CORRUGATED STEEL PIE IS USED.

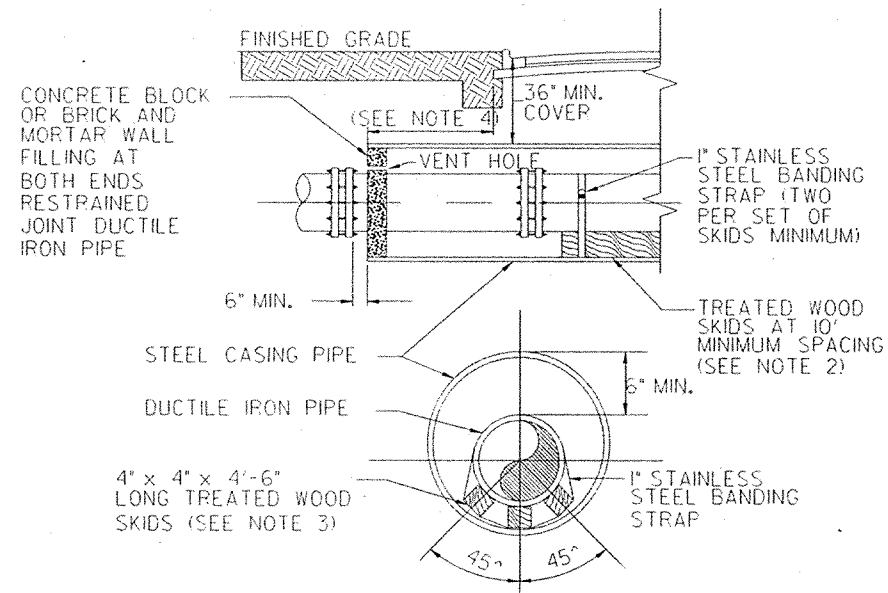

NOTES:

- CASING SPACERS, MAY BE REQUIRED BY THE CITY OR MAY BE SUBSTITUTED IN LIEU OF WOOD SKIDS AND BANDING STRAP.
- LARGER SKIDS SHALL BE REQUIRED FOR PIPE GREATER THAN 24" DIAMETER.
- WHERE PRACTICAL, CASING SHALL EXTEND 10' BEYOND EDGE OF PAVEMENT AND SHALL NOT BE LESS THAN 6' BEYOND EDGE OF PAVEMENT IN ANY CASE. THE CITY MAY REQUIRE LONGER CASING FOR DEEPER BORES.

CITY OF HEATH
J. Bern
 DIRECTOR OF UTILITIES

DATE
 05-1997

STANDARD CONSTRUCTION DRAWING
 CASING PIPE

NUMBER
 WA-12

1 / 1

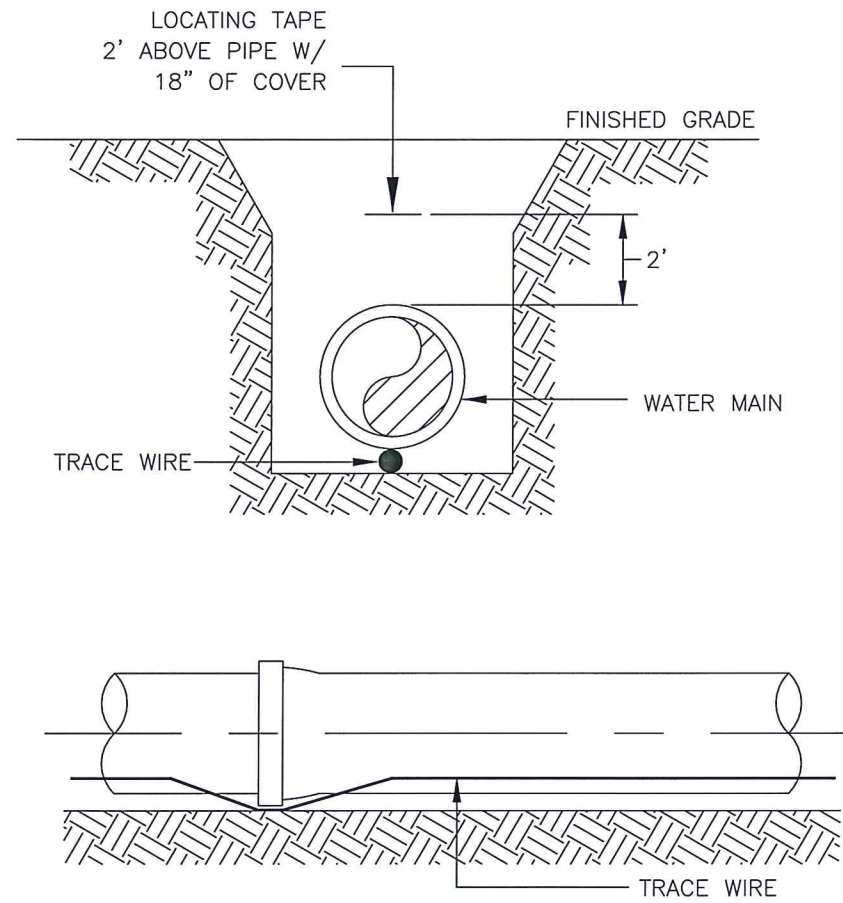

NOTES:

1. ALL PIPE SHALL REQUIRE TRACE WIRE CAPABLE OF DETECTION BY A LOCATOR AND ALL PIPE SHALL HAVE METALLIC LOCATING TAPE.
2. TRACE WIRE SHALL BE INSTALLED ON THE BOTTOM HALF OF THE PIPE BELOW THE SPRING LINE, AND SHALL REACH THE TOP OF EACH VALVE BOX ON THE NORTH OR EAST SIDE OF THE VALVE BOX.
3. USE DUCT TAPE OR TIES AS NECESSARY TO HOLD WIRE DIRECTLY ON THE PIPE.
4. METALLIC LOCATING TAPE SHALL BE BURIED 2' ABOVE ALL PIPE WITH 18" OF COVER.

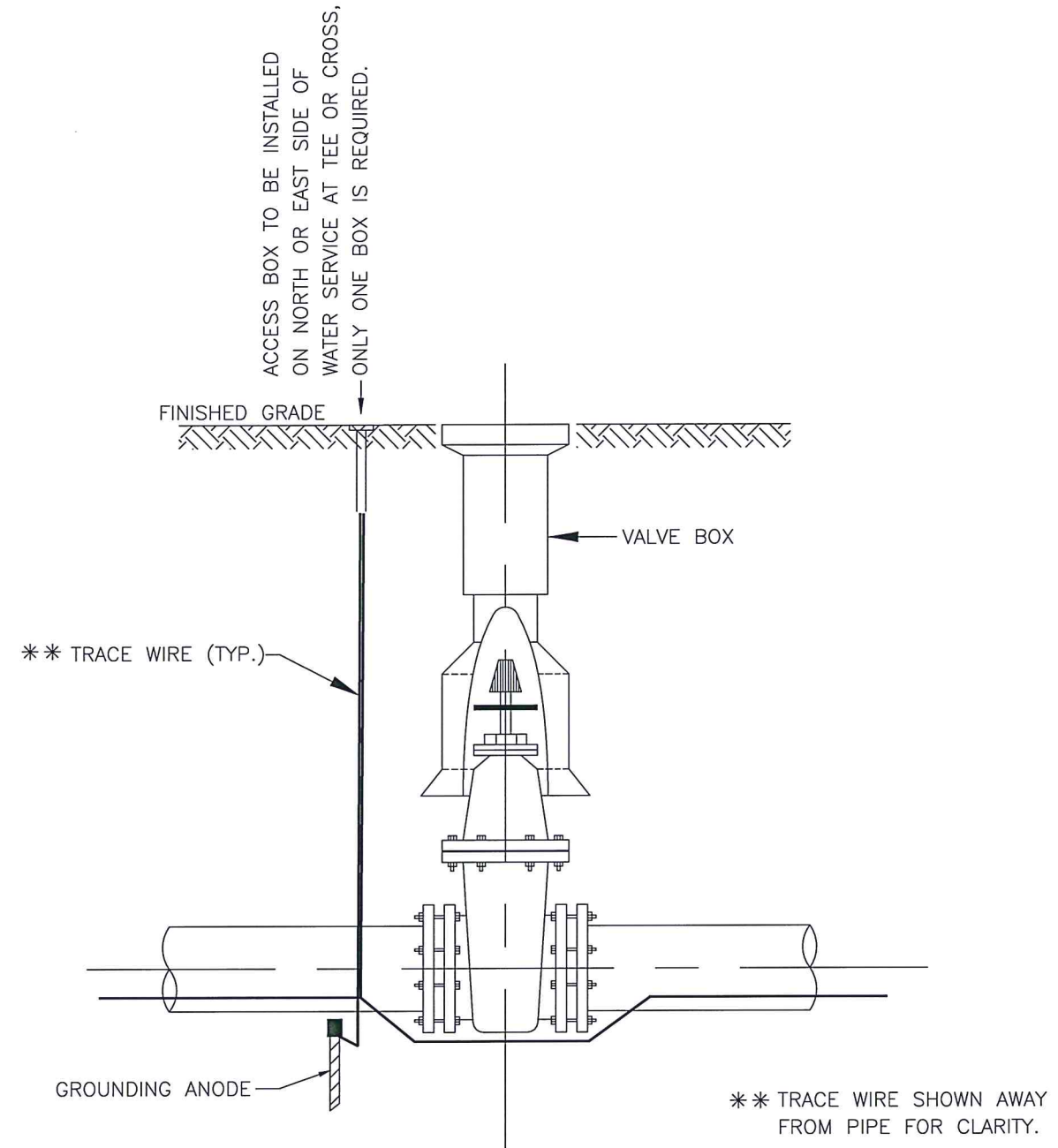

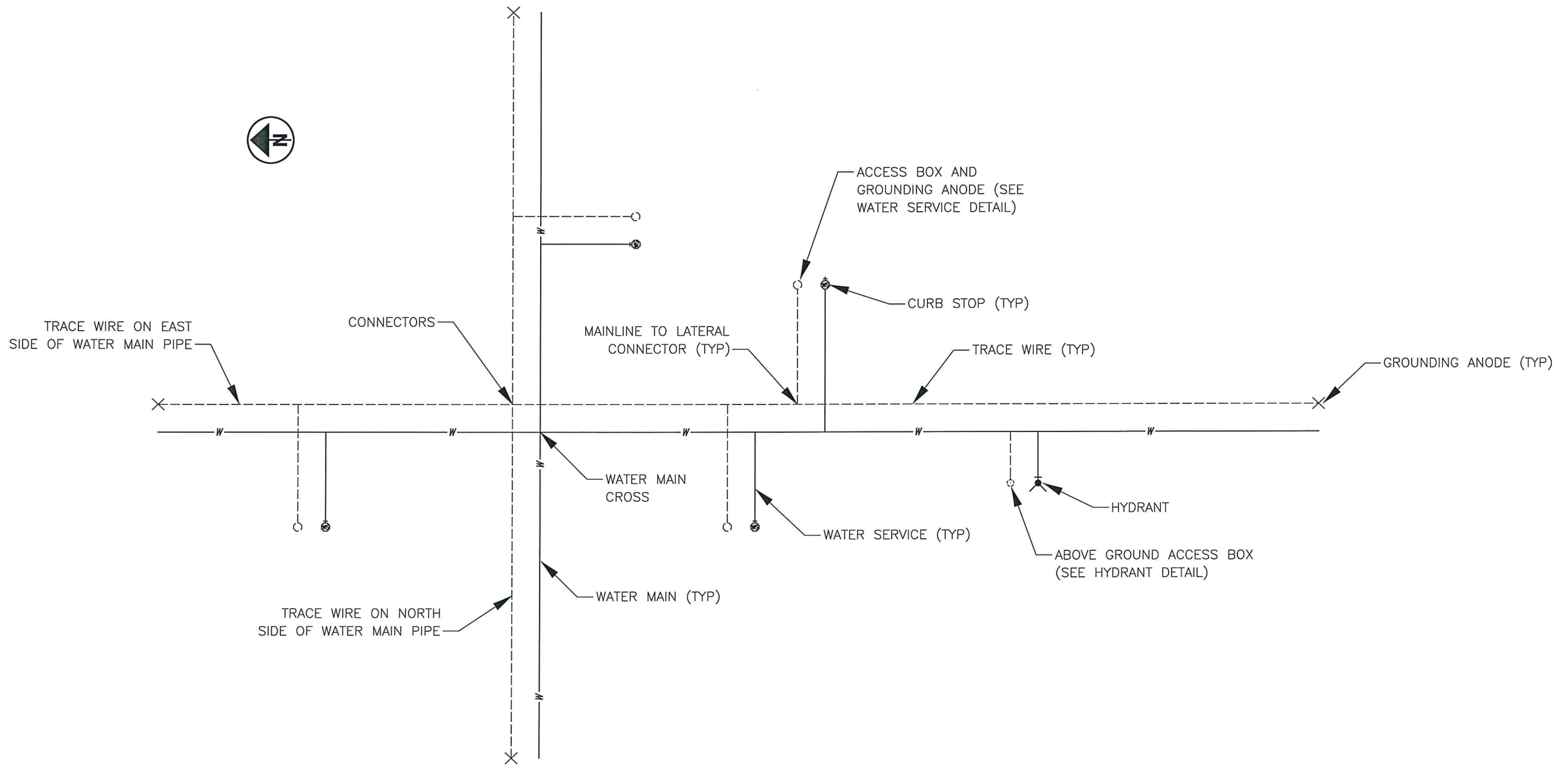

NOTES:

1. TRACE WIRE SHOWN AWAY FROM PIPE FOR CLARITY.
2. TRACE WIRE SHALL BE INSTALLED ON THE BOTTOM HALF OF THE PIPE BELOW THE SPRING LINE. THE TRACE WIRE SHALL BE FASTENED TO THE PIPE WITH DUCT TAPE OR PLASTIC TIES AT 5' INTERVALS.

3/12/2012 8:39:57 AM shaines M:\CH\2012-03_Sid Dwg\dm\sheets\Erosion Control\10-1-09-ER-0.dgn

E01 - STORM WATER POLLUTION PREVENTION

THE CONDITIONS OF THE NPDES CONSTRUCTION STORM WATER GENERAL PERMIT SHALL BE MET DURING ALL STAGES OF CONSTRUCTION. THE LOCATION AND TIMING OF ALL EROSION AND SEDIMENT CONTROL ITEMS SHALL BE FIELD ADJUSTED TO PREVENT SIGNIFICANT IMPACTS ON RECEIVING WATERS. IMPLEMENTATION OF THE STORM WATER POLLUTION PREVENTION PLAN SHALL CONTINUE THROUGHOUT THE DURATION OF THE PROJECT OR UNTIL SUCH TIME THAT THE UPSLOPE DISTURBED AREAS ARE STABILIZED.

ALL REASONABLE ATTEMPTS SHOULD BE MADE TO MINIMIZE THE TOTAL AREA OF DISTURBED LAND.

Designer Note:
Use this note on all projects which require a Storm Water Pollution Prevention Plan.

CONSTRUCTION SEQUENCE

DURING CONSTRUCTION, THE CONTRACTOR SHALL PROVIDE PROPER SOIL EROSION MEASURES FOR PROTECTION OF ALL ADJOINING ROADS, LANDS AND STREAMS. REFER TO S.C.S. MANUAL "RAINWATER AND LAND DEVELOPMENT" AND ODOT "HANDBOOK FOR SEDIMENT AND EROSION CONTROL" FOR REQUIREMENTS.

THE CONTRACTOR SHALL PROVIDE SEDIMENT CONTROL AT ALL POINTS WHERE STORMWATER LEAVES THE LIMITS OF THE PROJECT, ALL POINTS WHERE STORM WATER ENTERS A STREAM THAT TRAVERSES THE PROJECT AND ALL POINTS WHERE STORM WATER ENTERS PORTIONS OF COMPLETED UNDERGROUND PIPING.

ALL EROSION AND SEDIMENT CONTROL MEASURES SHALL BE PLACED PRIOR TO OR AS THE FIRST STEP IN GRADING.

ALL STORM SEWER, SANITARY SEWER AND WATER MAIN TRENCHES SHALL BE MULCHED AND SEEDED WITHIN 7 DAYS AFTER BACKFILL. NO MORE THAN 500 FEET OF TRENCH SHALL BE OPEN AT ANY ONE TIME.

ELECTRIC POWER, TELEPHONE, CATV AND GAS SUPPLY TRENCHES SHALL BE COMPACTED, SEEDED AND MULCHED WITHIN 7 DAYS AFTER BACKFILL.

ALL TEMPORARY EARTH BERMS, DIVERSIONS, SEDIMENT TRAP EMBANKMENTS AND EARTH STOCKPILES SHALL BE SEEDED AND MULCHED FOR TEMPORARY VEGETATIVE COVER WITHIN 7 DAYS AFTER GRADING. STRAW MULCH OR EQUIVALENT IS REQUIRED.

ALL STORM SEWER INLETS SHALL BE PROTECTED BY SEDIMENT TRAPS WHICH WILL BE MAINTAINED AND MODIFIED AS REQUIRED AS CONSTRUCTION PROGRESSES.

SEDIMENT DEPOSITS SHALL BE REMOVED AFTER EACH RAINFALL OR WHEN THE LEVEL OF DEPOSIT REACHES APPROXIMATELY ONE-HALF THE HEIGHT OF THE BARRIER.

ANY DISTURBED AREA NOT STABILIZED WITH SEEDING, SODDING, PAVING OR BUILT UPON BY NOVEMBER 1ST, OR AREAS DISTURBED AFTER THAT DATE, SHALL BE MULCHED IMMEDIATELY WITH STRAW AT THE RATE OF 3 TONS PER ACRE AND OVER-SEEDED BY MARCH 1ST.

AT THE COMPLETION OF CONSTRUCTION, ALL TEMPORARY SEDIMENT CONTROLS SHALL BE REMOVED AND ALL DENUDED AREAS SHALL BE STABILIZED. SEDIMENT DEPOSITS SHALL BE REGRADED AND SEEDED.

THE DESIGN OF EROSION AND SEDIMENT CONTROL SYSTEMS SHALL FOLLOW THE REQUIREMENTS OF OHIO EPA, ITEM 207 OF ODOT STANDARD SPECIFICATIONS AND THE REQUIREMENTS OF THE LOCAL JURISDICTION.

POST CONSTRUCTION STORM WATER MANAGEMENT

THE POST CONSTRUCTION RUNOFF WILL BE TREATED UTILIZING VEGETATED BIOFILTER SWALES FOR DITCH SECTIONS. IN ADDITION EXISTING WETLANDS ALONG THE PROJECT WILL BE LEFT UNDISTURBED.

MAINTENANCE NOTES

CONSTRUCTION ENTRANCE:

INSPECT THE MEASURE ON A REGULAR BASIS AND AFTER THERE HAS BEEN A HIGH VOLUME OF TRAFFIC OR A STORM EVENT. APPLY ADDITIONAL STONE PERIODICALLY AND WHEN REPAIR IS REQUIRED. IMMEDIATELY REMOVE SEDIMENT OR OTHER MATERIALS TRACKED ONTO THE PUBLIC ROADWAY. ENSURE THAT ASSOCIATED SEDIMENT CONTROL MEASURES ARE IN GOOD WORKING ORDER.

INLET PROTECTION:

THE STRUCTURE SHALL BE INSPECTED AFTER EACH RAIN AND REPAIRS MADE AS NEEDED. SEDIMENT SHALL BE REMOVED AND THE STRUCTURE RESTORED TO ITS ORIGINAL DIMENSIONS WHEN THE SEDIMENT HAS ACCUMULATED TO 1/4 THE DESIGN DEPTH OF THE STRUCTURE. REMOVED SEDIMENT SHALL BE DEPOSITED IN A SUITABLE AREA AND IN SUCH A MANNER THAT IT WILL NOT ERODE. STRUCTURES SHALL BE REMOVED AND THE AREA STABILIZED WHEN THE REMAINING DRAINAGE AREA HAS BEEN PROPERLY STABILIZED.

SILT FENCE:

SILT FENCE AND FILTER BARRIERS SHALL BE INSPECTED IMMEDIATELY AFTER EACH RAINFALL AND AT LEAST DAILY DURING PROLONGED RAINFALL. ANY REQUIRED REPAIRS SHALL BE MADE IMMEDIATELY. SHOULD THE FABRIC OF A SILT FENCE OR FILTER BARRIER DECOMPOSE OR BECOME INEFFECTIVE PRIOR TO THE END OF THE EXPECTED USABLE LIFE AND THE BARRIER IS STILL NECESSARY, THE FABRIC SHALL BE REPLACED IMMEDIATELY. SEDIMENT DEPOSITS SHOULD BE REMOVED AFTER EACH STORM EVENT. THEY MUST BE REMOVED WHEN DEPOSITS REACH APPROXIMATELY ONE-HALF THE HEIGHT OF THE BARRIER. ANY SEDIMENT DEPOSITS REMAINING IN PLACE AFTER THE SILT FENCE OR FILTER BARRIER IS NO LONGER REQUIRED SHALL BE DRESSED TO CONFORM WITH THE EXISTING GRADE.

DITCH CHECKS/ ROCK CHECK DAM:

DITCH CHECKS AND ROCK CHECKS SHALL BE INSPECTED IMMEDIATELY AFTER EACH RAINFALL AND AT LEAST DAILY DURING PROLONGED RAINFALL. ANY REQUIRED REPAIRS SHALL BE MADE IMMEDIATELY. SHOULD THE FABRIC OF A DITCH CHECK DECOMPOSE OR BECOME INEFFECTIVE PRIOR TO THE END OF THE EXPECTED USABLE LIFE AND THE BARRIER IS STILL NECESSARY, THE FABRIC SHALL BE REPLACED IMMEDIATELY. SEDIMENT DEPOSITS SHOULD BE REMOVED AFTER EACH STORM EVENT. THEY MUST BE REMOVED WHEN DEPOSITS REACH APPROXIMATELY ONE-HALF THE HEIGHT OF THE BARRIER. ANY SEDIMENT DEPOSITS REMAINING IN PLACE AFTER THE SILT FENCE OR FILTER BARRIER IS NO LONGER REQUIRED SHALL BE DRESSED TO CONFORM WITH THE EXISTING GRADE.

SEDIMENT TRAPS:

EACH SEDIMENT TRAP SHALL BE INSPECTED EVERY SEVEN DAYS AND AFTER EACH 0.5 INCH RAINFALL AND SEDIMENT REMOVED AFTER 6 INCHES OF SEDIMENT HAS ACCUMULATED. THE FUNCTION OF THESE TRAPS ARE TO REMOVE SEDIMENT LADEN WATER. UPON COMPLETION OF THE PROJECT THE SEDIMENT TRAP SHALL BE REMOVED AND DRESSED TO CONFORM TO THE GRADING SHOWN WITHIN THE CONSTRUCTION PLANS.

SPECIFICATIONS FOR SEEDING AND MULCHING			
SEED TYPE	SEEDING DATES	PER 1000 SQ.FT.	PER ACRE
TALL FESCUE AND ANNUAL RYEGRASS	MARCH 1 TO SEPTEMBER 15	2 POUND AND 1/2 POUND	90 POUNDS AND 20 POUNDS
SMALL GRAIN STRAW MULCH		100 POUNDS OR 2 TO 3 BALES	2 TONS OR 50 BALES
FERTILIZER		25 POUNDS OF 12-12-12 OR THE EQUIVALENT	1000 POUNDS OF 12-12-12 OR THE EQUIVALENT
TEMPORARY SEEDING			
KY 31 AND ANNUAL RYEGRASS	MARCH 1 TO SEPTEMBER 15	1 POUND	40 POUNDS AND 20 POUNDS
RYE OR WHEAT	SEPTEMBER 15 TO OCTOBER 30	3 POUNDS	2 BUSHELS
SOIL PROTECTION			
SMALL GRAIN STRAW MULCH	OCTOBER 30 TO MARCH 1	2 TO 3 BALES	3 TONS

TEMPORARY STABILIZATION

AREA REQUIRING TEMPORARY STABILIZATION	TIME FRAME TO APPLY EROSION CONTROLS
ANY DISTURBED AREAS WITHIN 50 FEET OF A STREAM AND NOT AT FINAL GRADE	WITHIN 2 DAYS OF THE MOST RECENT DISTURBANCE IF THE AREA WILL REMAIN IDLE FOR MORE THAN 21 DAYS
FOR ALL CONSTRUCTION ACTIVITIES, ANY DISTURBED AREAS THAT WILL BE DORMANT FOR MORE THAN 21 DAYS BUT LESS THAN 1 YEAR, AND NOT WITHIN 50 FEET OF A STREAM	WITHIN 7 DAYS OF THE MOST RECENT DISTURBANCE WITHIN THE AREA FOR RESIDENTIAL SUBDIVISIONS, DISTURBED AREAS MUST BE STABILIZED AT LEAST 7 DAYS PRIOR TO TRANSFER OF PERMIT COVERAGE FOR THE INDIVIDUAL LOT(S).
DISTURBED AREAS THAT WILL BE IDLE OVER WINTER	PRIOR TO THE ONSET OF WINTER WEATHER WITHIN 7 DAYS OF REACHING FINAL GRADE WITHIN THAT AREA

PERMANENT STABILIZATION

AREA REQUIRING PERMANENT STABILIZATION	TIME FRAME TO APPLY EROSION CONTROLS
ANY AREAS THAT WILL LIE DORMANT FOR ONE YEAR OR MORE	WITHIN 7 DAYS OF THE MOST RECENT DISTURBANCE
ANY AREAS WITHIN 50 FEET OF A STREAM AND AT FINAL GRADE	WITHIN 2 DAYS OF REACHING FINAL GRADE
ANY OTHER AREAS AT FINAL GRADE	WITHIN 7 DAYS OF REACHING FINAL GRADE WITHIN THAT AREA

CITY OF HEATH
ZONING SUPERINTENDENT
[Signature]

DATE
10-2009
02-2012

STANDARD CONSTRUCTION DRAWING
EROSION AND SEDIMENT CONTROL SPECIFICATIONS & NOTES

NUMBER
ER-0

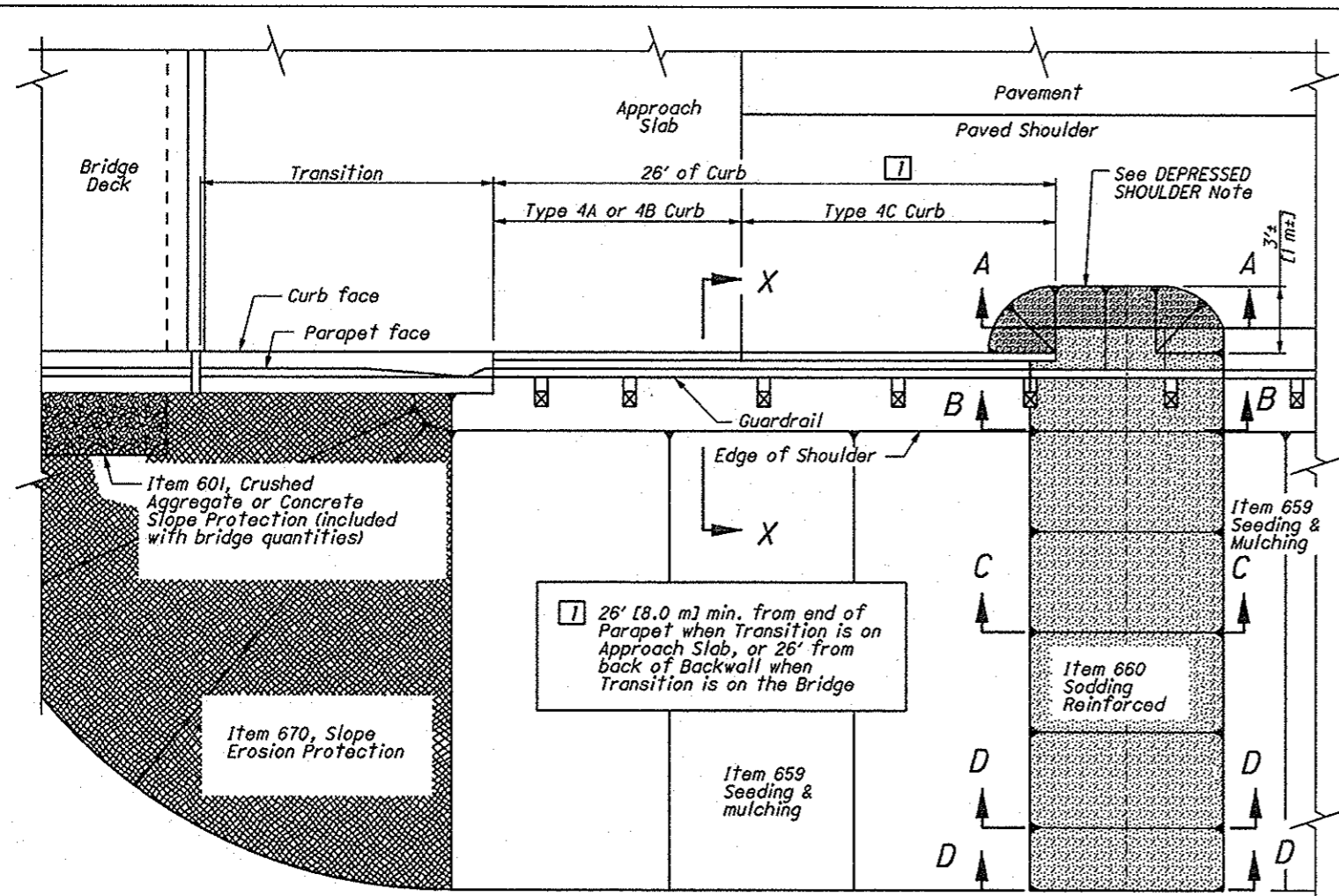

PLAN

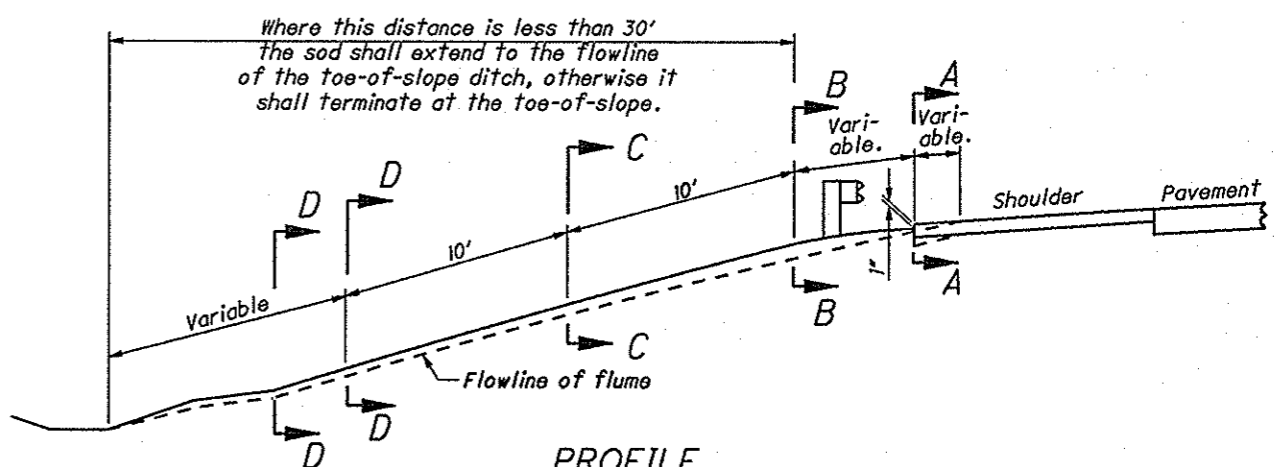

PROFILE

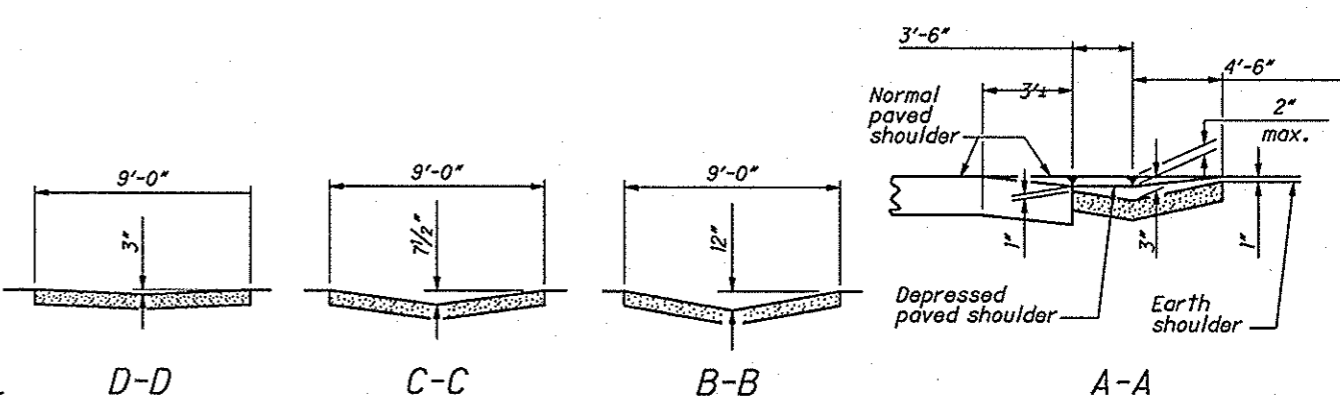

CROSS SECTIONS

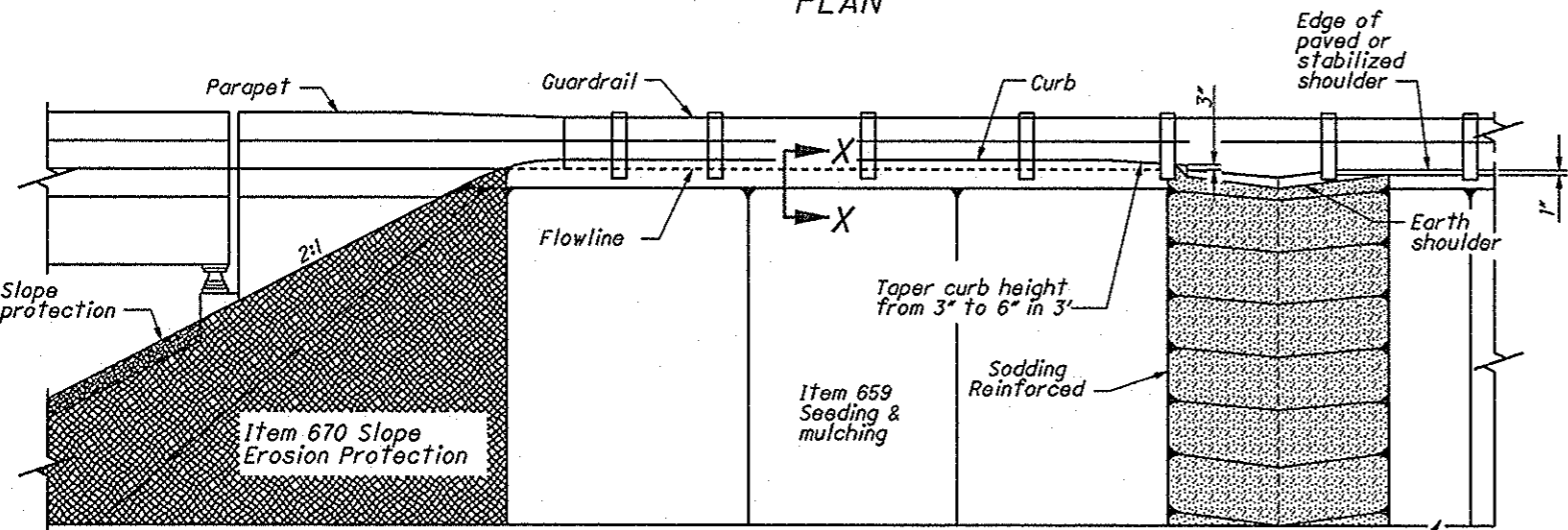

ELEVATION

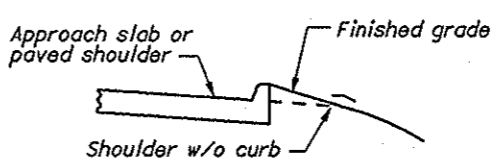

SECTION X-X

NOTES

DEPRESSED SHOULDER: This portion of the shoulder shall be depressed to ensure positive drainage into the sodded flume. It is especially important in the shoulder area to excavate and shape the subgrade according to the cross sections.

PLACING REINFORCED SODDING: Prior to placing the sod, galvanized poultry netting shall be placed on the finished subgrade. The netting shall be 4' wide, poultry netting or equivalent, with 2" mesh and No. 20 gage minimum wire. Each strand shall be staked securely to the subgrade by using T-shaped pins or 1"x1"x8" wood stakes. The stakes or pins shall be placed at 4" intervals on the top and bottom and in rows 4' apart. Fasten the poultry netting to the wood stakes with staples. Where the sodding is from 8' to 9' wide, two strands of netting for a total width of 8' is permitted.

SOD: Sod shall be laid in accordance with CMS 660. Special care shall be taken to excavate the sod bed to a proper depth so that the sod is flush with the surrounding grade.

PAYMENT: Payment for all the above shall be included in the unit price bid for Item 660, Sodding REinforced, Square Yard.

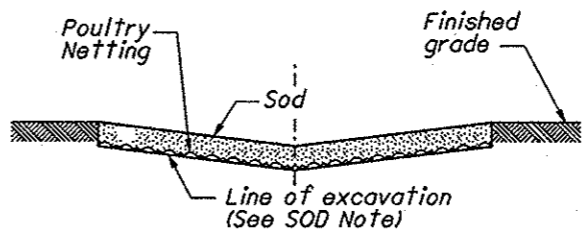

SOD INSTALLATION DETAIL

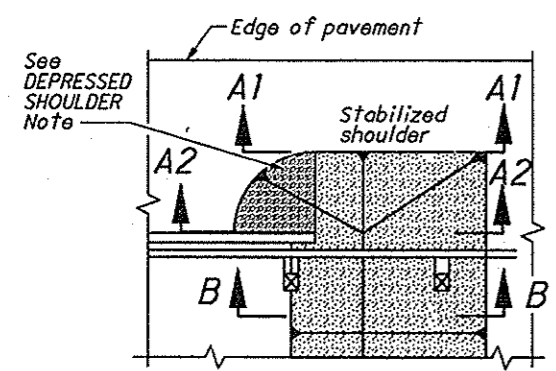

STABILIZED SHOULDER DETAIL

12/1/2009 9:22:11 AM shaines M:\CH2009-00\dgn\sheets\11-3-09 ER-1.dgn

CITY OF HEATH
ZONING SUPERINTENDENT
John W. Huff

DATE
11-2009

STANDARD CONSTRUCTION DRAWING
EROSION CONTROL AT BRIDGES

NUMBER
ER-1

1/1

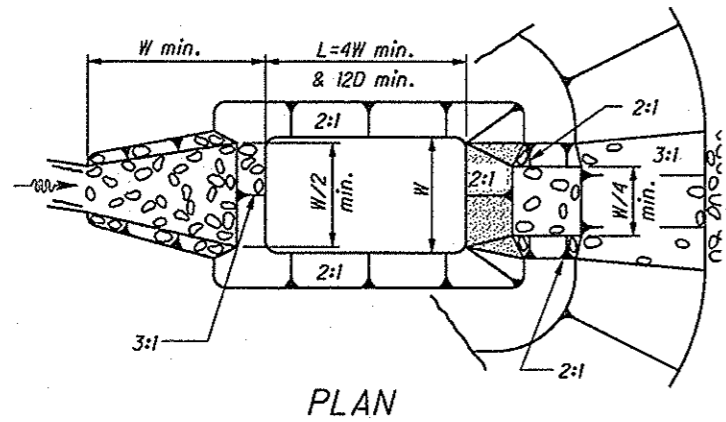

PLAN

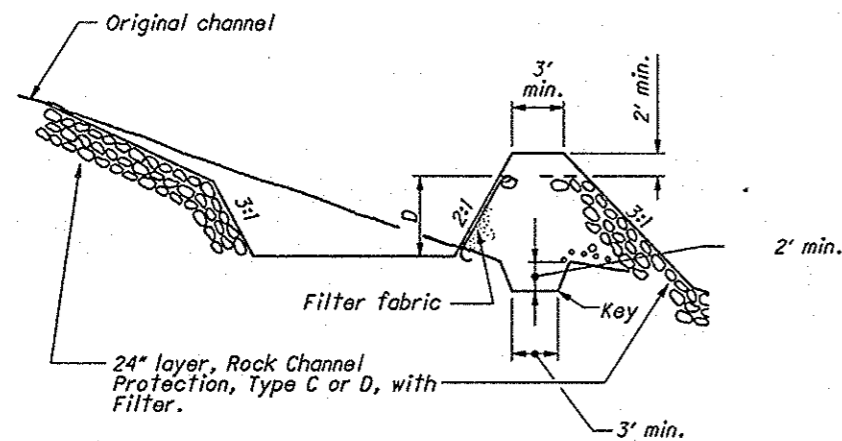

PROFILE
SEDIMENT DAM
(Drainage Area of Less Than 5 Acres)

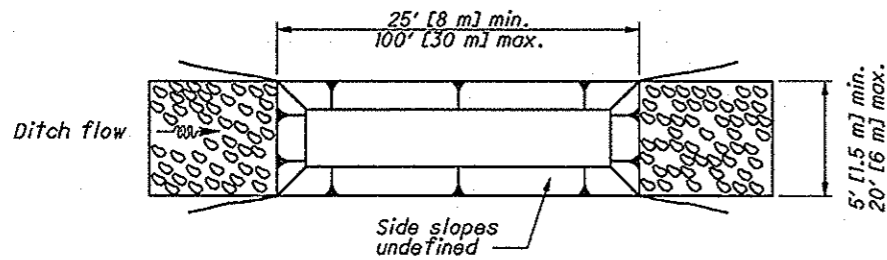

PLAN

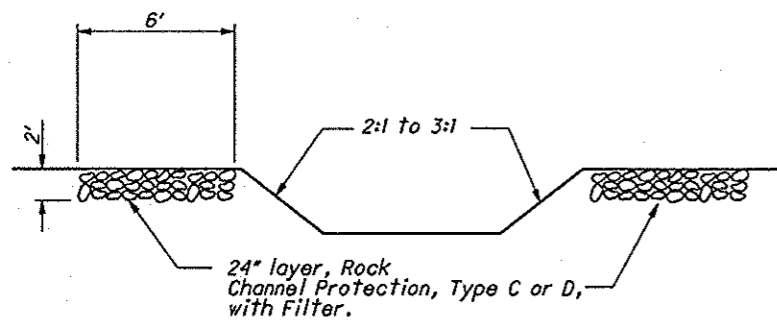

PROFILE
SEDIMENT BASIN
(Drainage Area of Less Than 5 Acres)

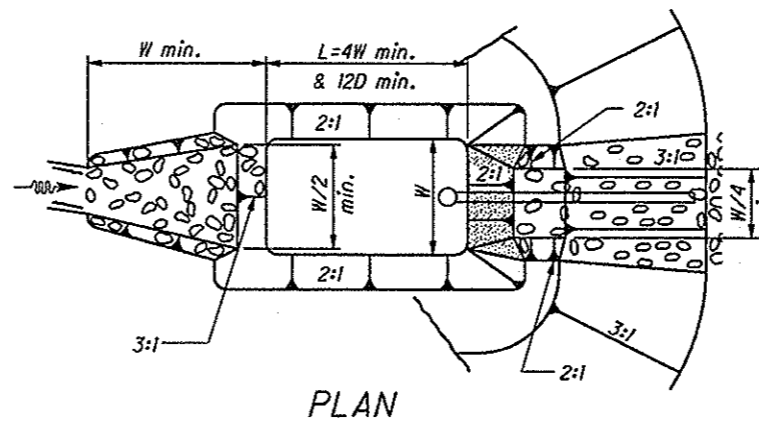

PLAN

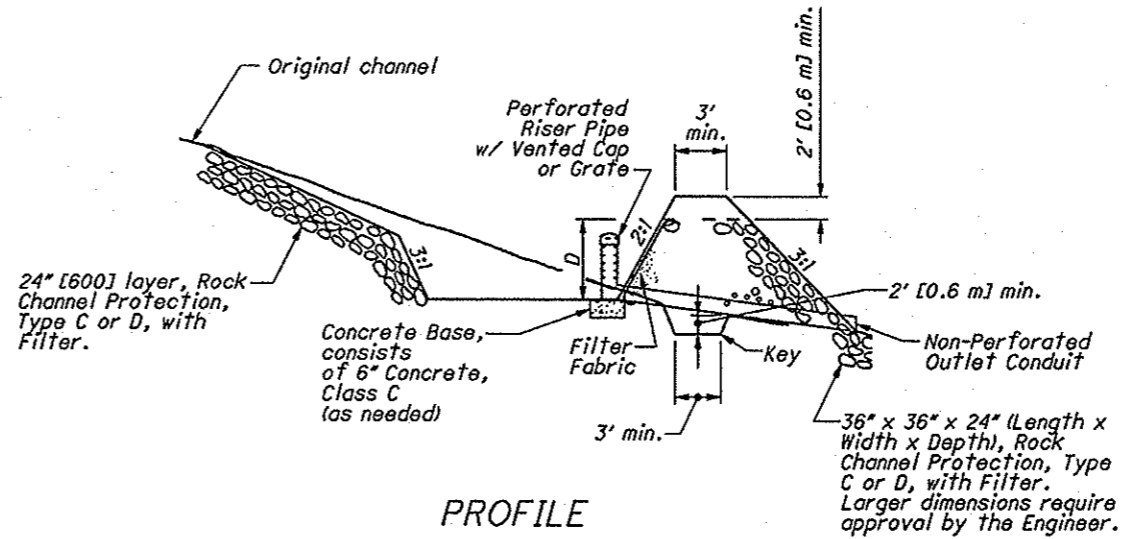

PROFILE
SEDIMENT DAM
(Drainage Area of 5 Acres or More)

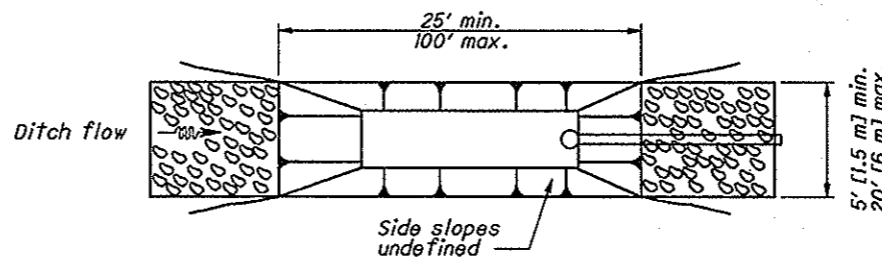

PLAN

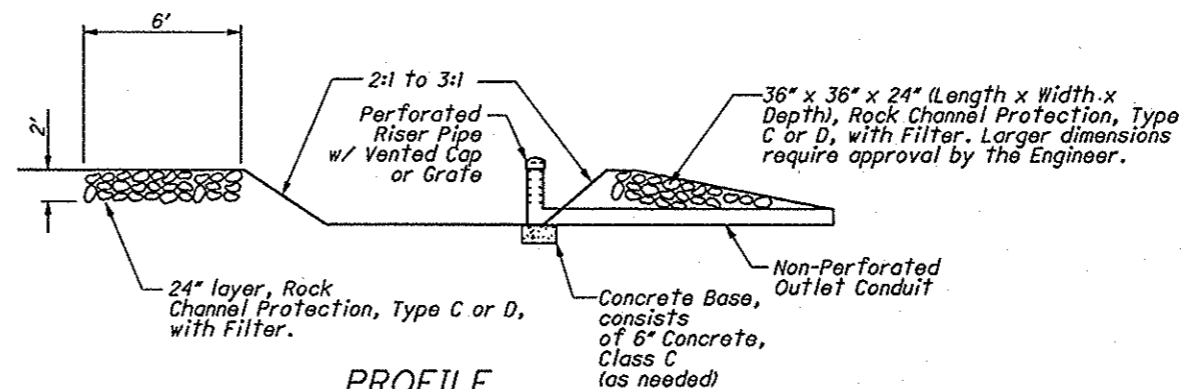

PROFILE
SEDIMENT BASIN
(Drainage Area of 5 Acres or More)

NOTES

MATERIAL:

Furnish materials conforming to Item 203, Embankment and Item 601, Rock Channel Protection, Type C or D with filter. Furnish construction fence consisting of 4'-0" [1.3 m] high plastic fence with 6' [2 m] long metal fence posts.

CONSTRUCTION:

Construct the Basin and Dams as detailed. Construct the construction fence in urban areas or in high pedestrian traffic areas. Construct the fence to completely surround the sediment basin or dam. Place the fence post on 8' [2.6 m] centers, 2' [0.6 m] deep. Securely attach the plastic construction fence to the fence post.

PAYMENT:

The Department will pay for accepted quantities at the prices shown in Appendix F of Supplemental Specification 832 (SS832) for the following items:

- Sediment Basins and Dams
- Rock Channel Protection, Type C or D, with Filter

All items shown on this Standard Construction Drawing that are required for construction that are not specifically identified in SS832 Appendix F are considered incidental.

RISER PIPE:

Use schedule 40 Polyvinyl Chloride Conduit.

CITY OF HEATH
ZONING SUPERINTENDENT
John W. Huff

DATE
11-2009

STANDARD CONSTRUCTION DRAWING
SEDIMENT AND EROSION CONTROLS

NUMBER
ER-2

1 / 2

DIKES AND SLOPE DRAINS

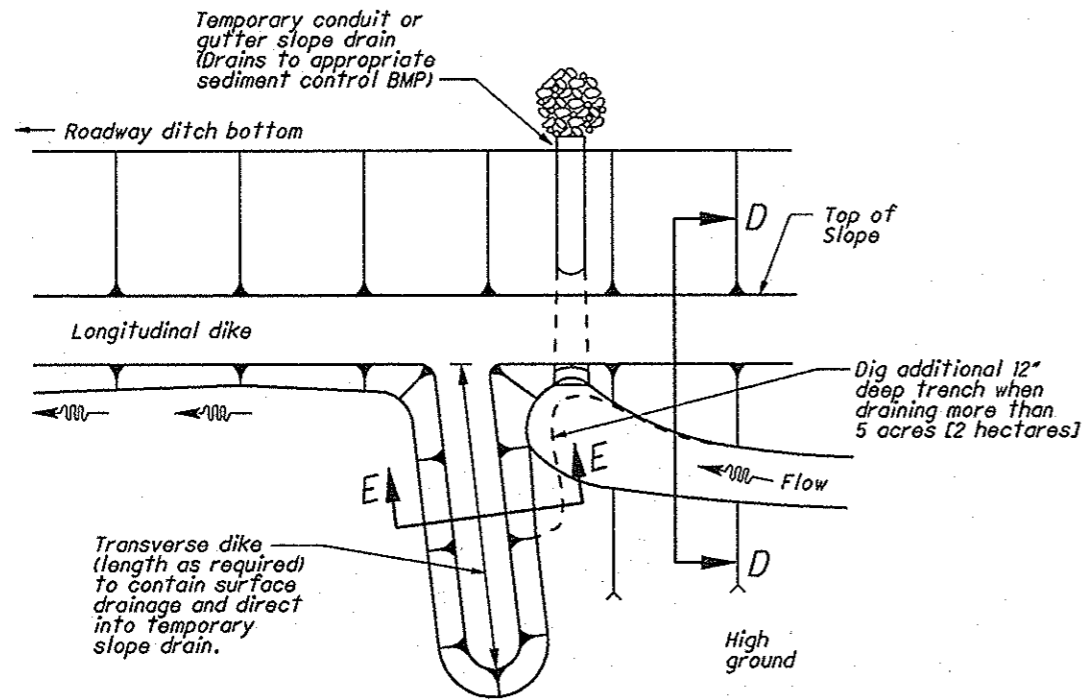

PLAN VIEW

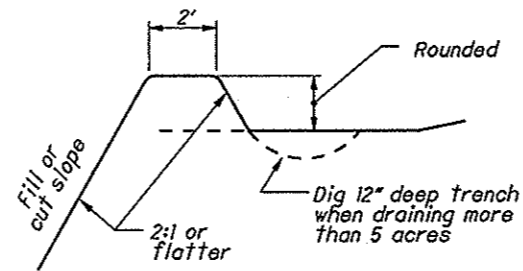

SECTION D-D

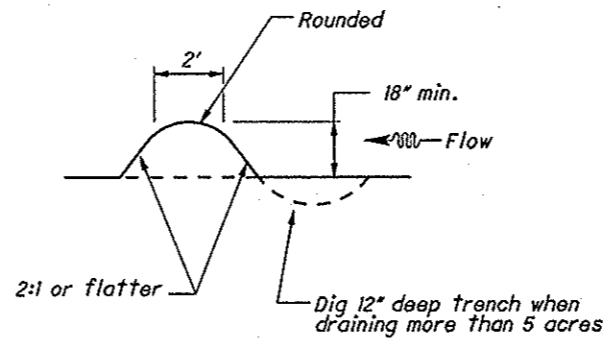

SECTION E-E

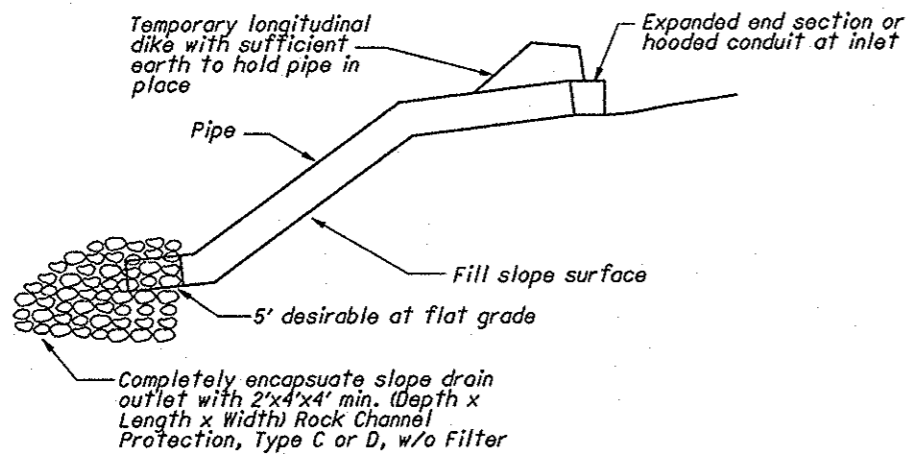

CONDUIT SLOPE DRAIN

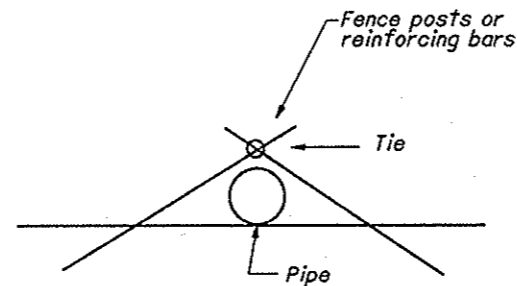

TIE-DOWN SLOPE DRAIN

NOTES

MATERIAL:

Furnish materials conforming to Item 203, Embankment and Item 601, Rock Channel Protection, Type C or D, without filter.

Furnish the following for the slope drains: corrugated steel pipe, corrugated or smooth plastic pipe, reinforcing bars or fence posts.

CONSTRUCTION:

Construct as detailed. Compact the dike to 85% of Standard Proctor.

Use reinforcing bars or fence posts to tie down the slope drains and to keep the pipe from moving.

Ensure that the water entering the slope drain inlet does not erode or degrade the dike section containing the temporary conduit.

PAYMENT:

The Department will pay for accepted quantities at the prices shown in Appendix F of Supplemental Specification 832 (SS832) for the following items:

- Slope Drains
- Dikes
- Rock Channel Protection, Type C or D, without Filter

All items shown on this Standard Construction Drawing that are required for construction that are not specifically identified in SS832 Appendix F are considered incidental.

TEMPORARY SLOPE DRAINS RECOMMENDED SIZES		
AREA in acres [hectares]	PIPE SIZES	
	Smooth	Corrugated
0-4	6"	6"
4-8	8"	12"
8-12	10"	15"

CITY OF HEATH
 ZONING SUPERINTENDENT
 DATE 11-2009
 STANDARD CONSTRUCTION DRAWING
 SEDIMENT AND EROSION CONTROLS
 NUMBER ER-2
 2 / 2

12/1/2009 9:22:15 AM shaines M:\CH2009-00\cso\sheets\11-3-09 ER-2.dgn

DITCH CHECKS

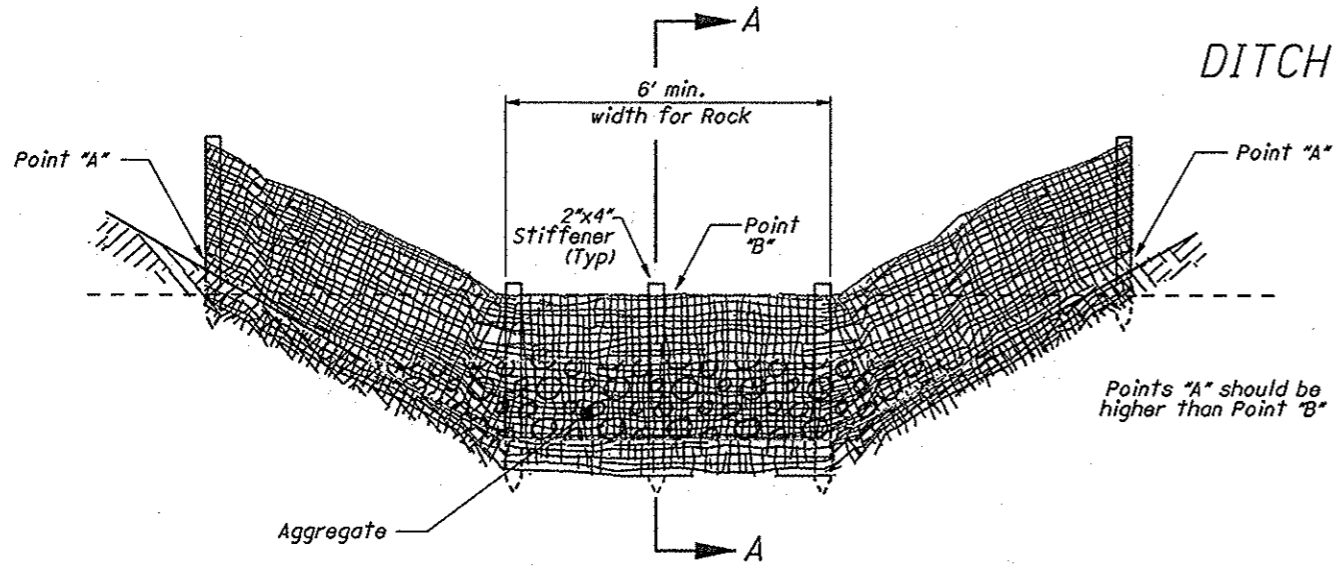

CROSS-SECTIONAL VIEW OF FLAT BOTTOM DITCH

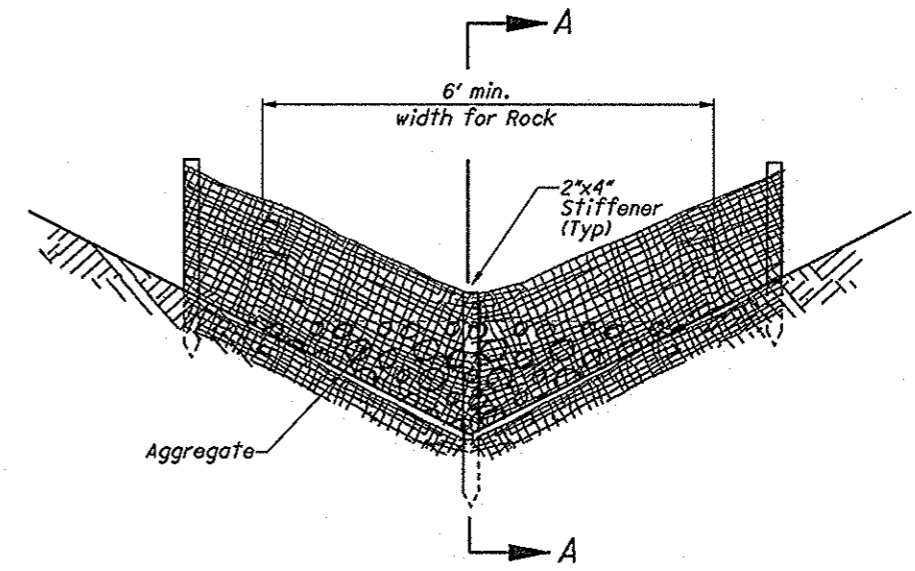

CROSS-SECTIONAL VIEW OF "V" DITCH

NOTES

FILTER FABRIC DITCH CHECKS:

MATERIALS:

Furnish filter fabric ditch checks consisting of the following materials:

1. 30" wide filter fabric with sound wood supports with maximum on-center spacing of 10'. Use filter fabric conforming to 712.09, Type C.
2. A vertically driven 2"x4" stiffener stake in the center of the ditch.
3. Aggregate conforming to one of the following gradations No. 1 through No. 4 on Table 703.01-1.

When using straw bales, furnish 30" long 2"x2" wooden stakes, reinforcing bars or fence posts to stake straw bales in place.

CONSTRUCTION:

Trench the filter fabric fence as detailed for PERIMETER FILTER FABRIC FENCE (see Sheet 2). Place a vertical 2"x4" stiffener stake in the center of the ditch with the top level to the top of the fence and at least 6" [150] below the bottom of the ditch. Excavate for aggregate and place the aggregate on the downstream side of the ditch check.

If the Engineer determines that rock should not be used for the filter fabric ditch checks, replace aggregate with straw bales configured with minimal gaps between bales. Tightly place each bale adjacent to one another. Entrench 2" to 3" into the ground prior to staking. Firmly stake each bale with at least two stakes.

PAYMENT:

The Department will pay for accepted quantities at the prices shown in Appendix F of Supplemental Specification 832 (SS832) for the following items:

- Filter Fabric Ditch Check

All items shown on this Standard Construction Drawing that are required for construction that are not specifically identified in SS832 Appendix F are considered incidental.

NOTES

ROCK CHECKS:

MATERIALS:

Furnish material conforming to Item 601 - Rock Channel Protection, Type C or D, without filter.

CONSTRUCTION:

If the Engineer determines that rock should not be used for the rock checks, replace rock channel protection with straw bales configured with minimal gaps between bales. Tightly place each bale adjacent to one another. Entrench 2" to 3" into the ground prior to staking. Firmly stake each bale with at least two stakes.

PAYMENT:

The Department will pay for accepted quantities at the prices shown in Appendix F of Supplemental Specification 832 (SS832) for the following items:

- Rock Channel Protection, Type C or D, without Filter

All items shown on this Standard Construction Drawing that are required for construction that are not specifically identified in SS832 Appendix F are considered incidental.

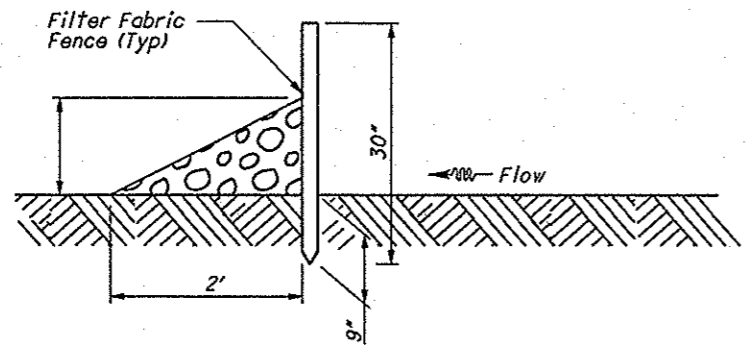

PROFILE VIEW OF FLAT BOTTOM AND V DITCH
 SECTION A-A

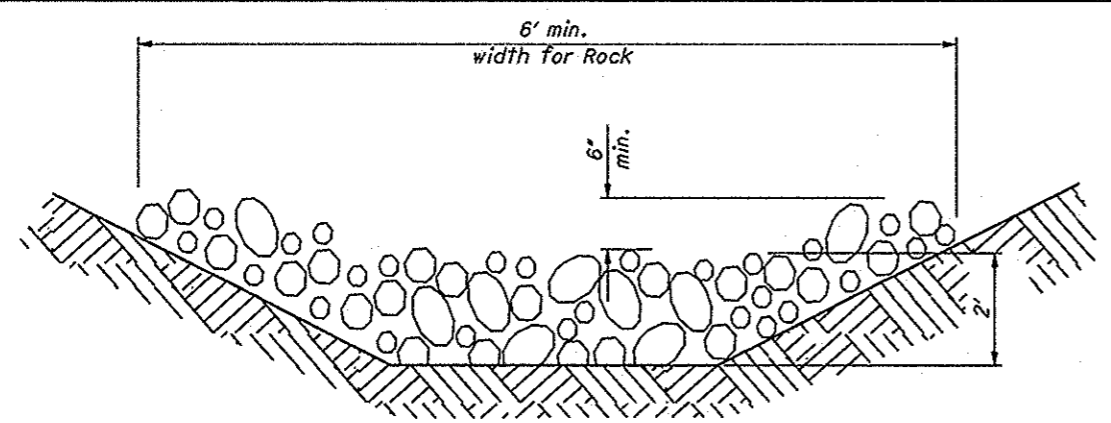

Minimum dimensions: 2' high x 6' wide x 3' long

CROSS-SECTIONAL VIEW
 ROCK CHECK

12/1/2009 9:22:19 AM shaines M:\CH2009-00\dsn\sheet\11-3-09 ER-3.dgn

PERIMETER FILTER FABRIC FENCE

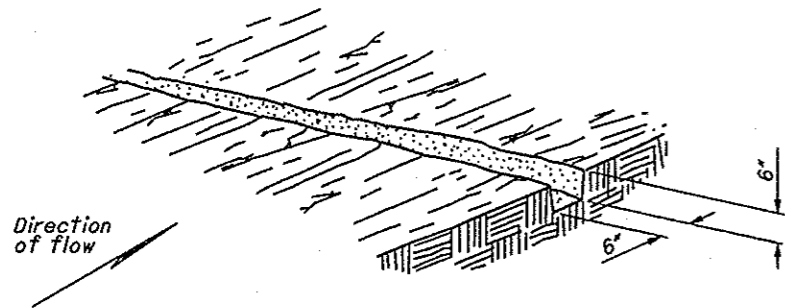

Excavate a 6"x6" trench along the proposed fence line.

STEP 1

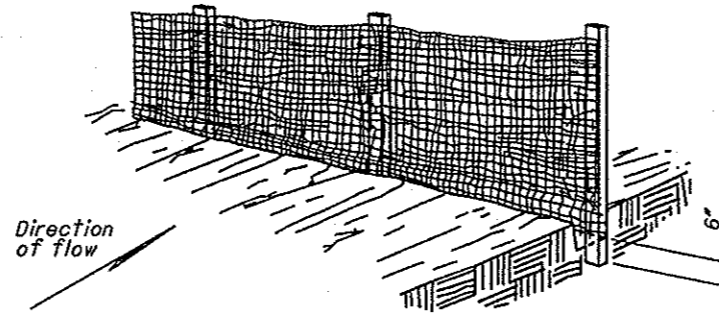

Place fabric and support stakes and extend fabric into the trench.

STEP 2

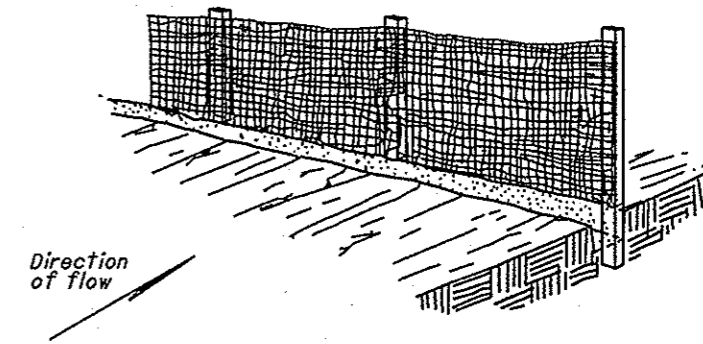

Backfill and compact the excavated soil.

STEP 3

NOTES

MATERIALS:

Furnish 30" wide filter fabric with sound wood supports with maximum on-center spacing of 10'. Use filter fabric conforming to 712.09, Type C.

CONSTRUCTION:

Trench the filter fabric fence as detailed. The contractor may elect to trench the fence detailed on steps 1 through 3 in one plowing operation.

PAYMENT:

The Department will pay for accepted quantities at the prices shown in Appendix F of Supplemental Specification 832 (SS832) for the following items:

- Perimeter Filter Fabric Fence

All items shown on this Standard Construction Drawing that are required for construction that are not specifically identified in SS832 Appendix F are considered incidental.

INLET PROTECTION

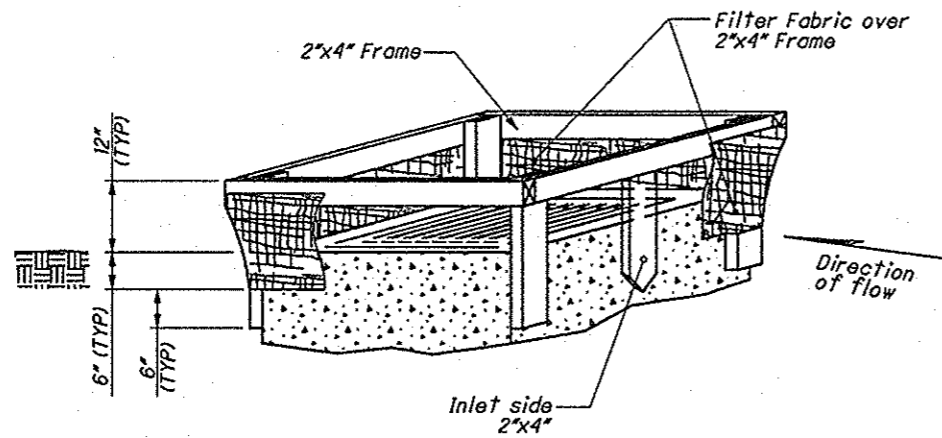

INLET PROTECTION

NOTES

MATERIALS:

Furnish inlet protection consisting of 18" wide filter fabric fence with a securely nailed 2"x4" wood frame with a vertically driven 2"x4" on the inlet, or flow, side of the structure. Use filter fabric conforming to 712.09, Type C.

CONSTRUCTION:

Construct an 18" wide filter fabric fence supported around a storm drain inlet or catch basin with a securely nailed 2"x4" wood frame. Excavate a 6" trench around the inlet, and drive support posts 6" below the excavated trench bottom. Stretch the fabric around the frame. Secure it tightly, ensuring that 6" of fabric is in the trench. Overlap the fabric on one side of the inlet so that the fabric ends are not attached to the same post. Backfill and compact the excavated soil tightly onto the fabric. Place a vertical 2"x4" in the center of the inlet so that the top is at the top of the fence and the bottom is at least 6" below the bottom of the ditch.

PAYMENT:

The Department will pay for accepted quantities at the prices shown in Appendix F of Supplemental Specification 832 (SS832) for the following items:

- Inlet Protection

All items shown on this Standard Construction Drawing that are required for construction that are not specifically identified in SS832 Appendix F are considered incidental.

12/1/2009 9:22:20 AM - shaines - M:\CH2009-00\dgn\sheets\11-3-09 ER-3.dgn

CITY OF HEATH
ZONING SUPERINTENDENT
John W. Heath

DATE
10-2009

STANDARD CONSTRUCTION DRAWING
CONSTRUCTION EROSION CONTROL

NUMBER
ER-3
2 / 2

12/1/2009 9:22:22 AM - shaines - M:\CH2009-00\dgn\sheets\11-3-09 ER-4.dgn

CITY OF HEATH
[Signature]
 ZONING SUPERINTENDENT

DATE
 11-2009

STANDARD CONSTRUCTION DRAWING
 TEMPORARY SEDIMENT BASIN

NUMBER
 ER-4

1 / 2

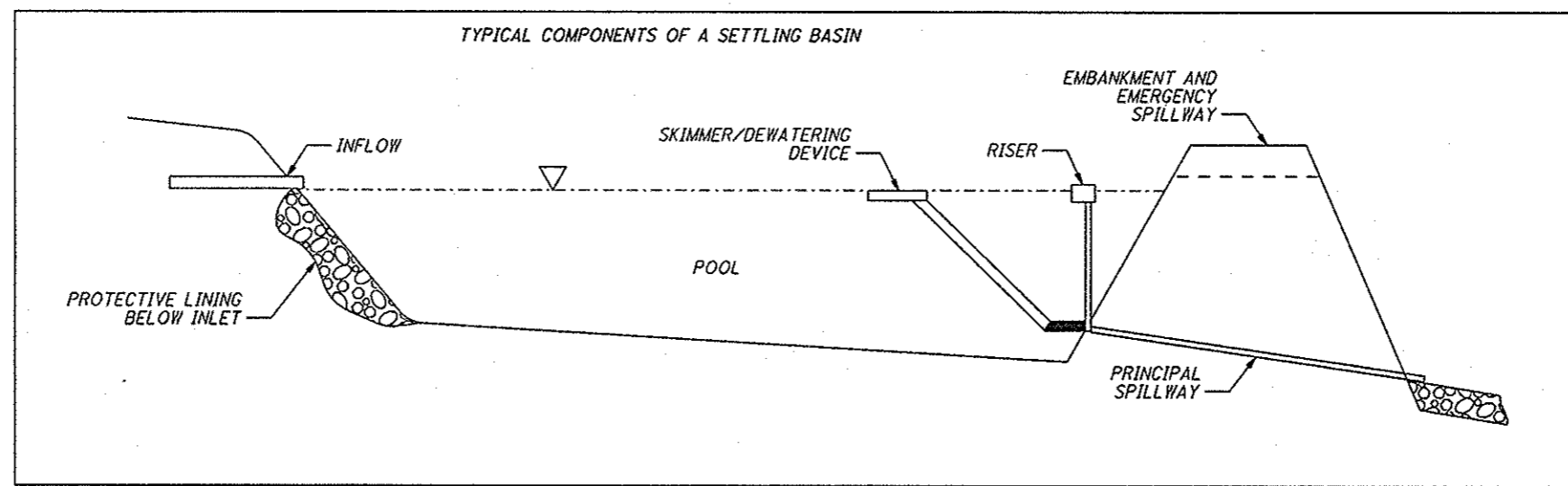
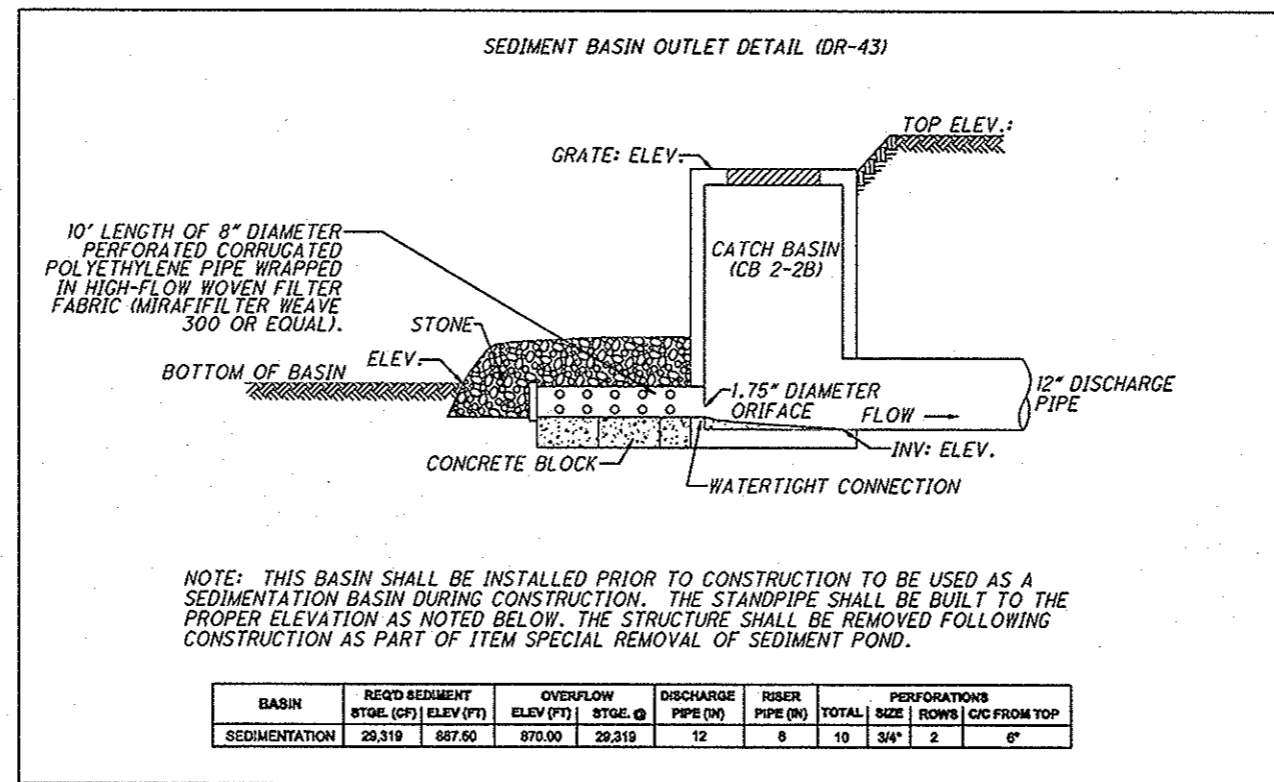

12/1/2009 9:22:23 AM shaines M:\CH2009-00\dgn\sheets\11-3-09 ER-4.dgn

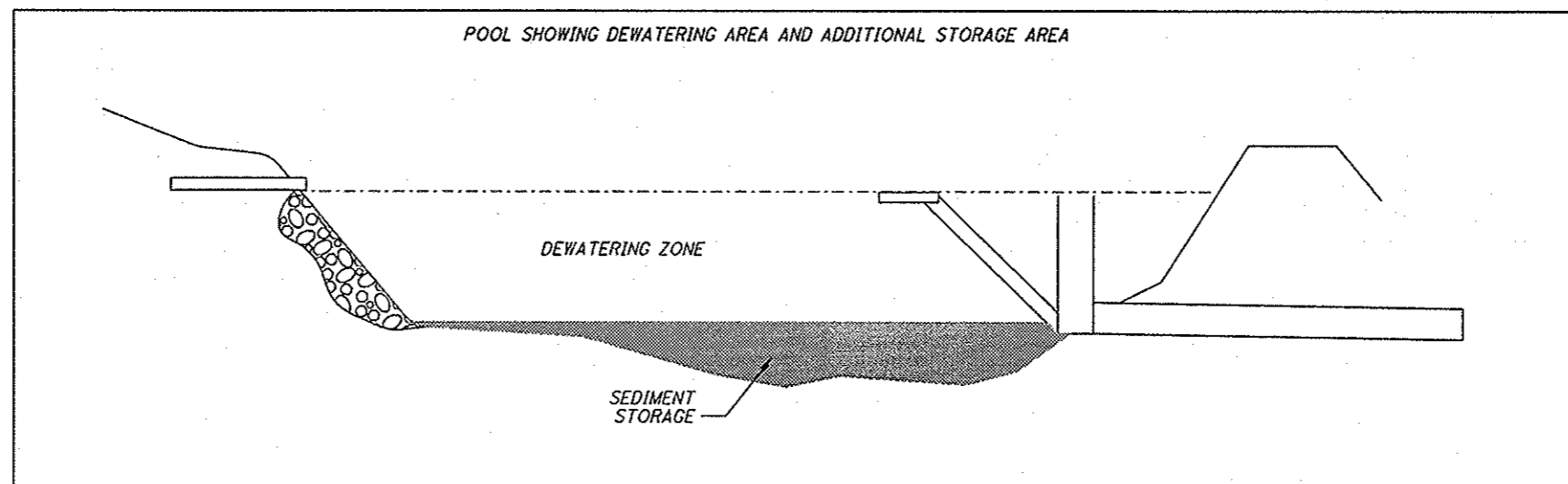
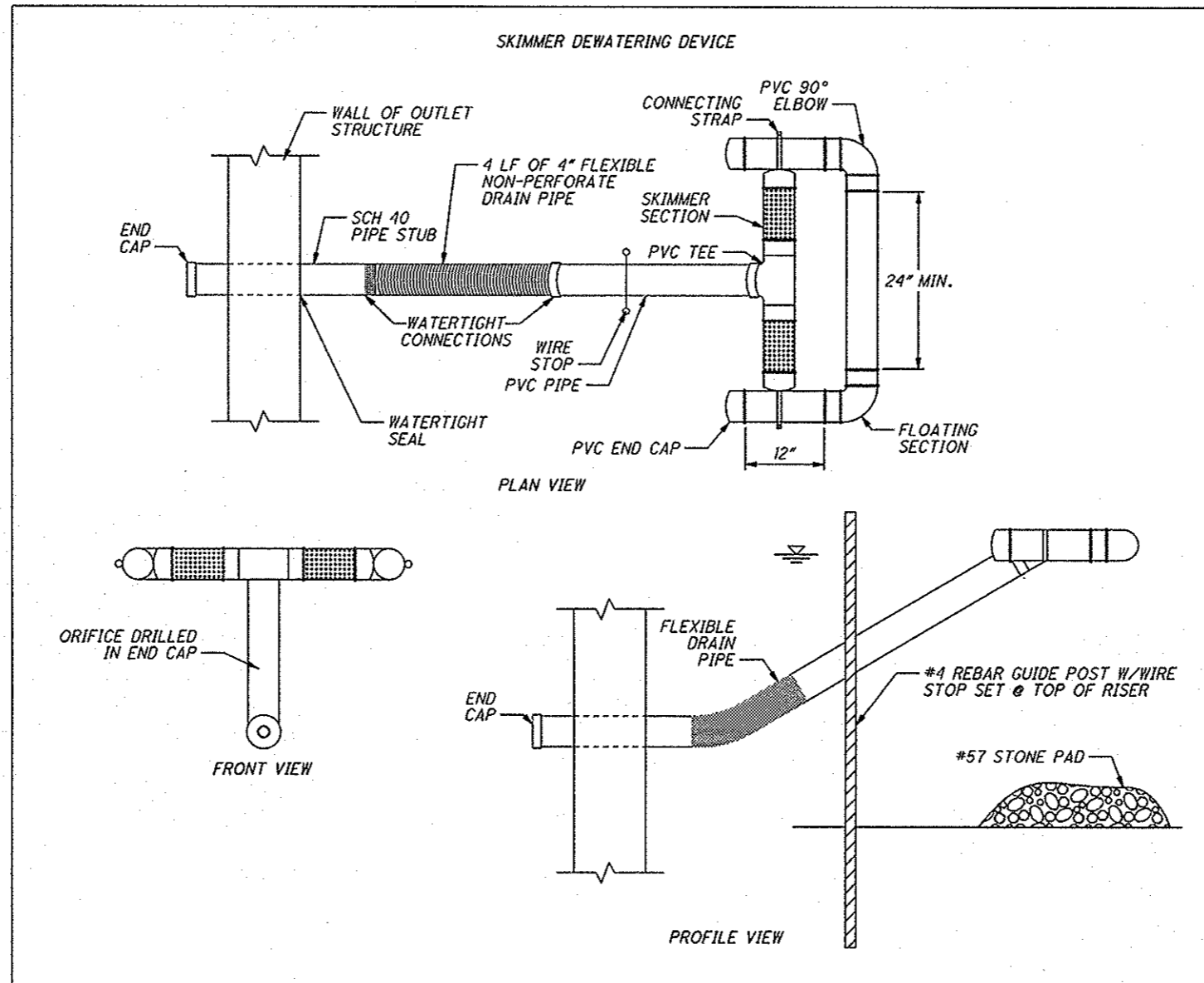

CITY OF HEATH
John W. Smith
ZONING SUPERINTENDENT

DATE
11-2009

STANDARD CONSTRUCTION DRAWING
TEMPORARY SEDIMENT BASIN

NUMBER
ER-4

2 / 2

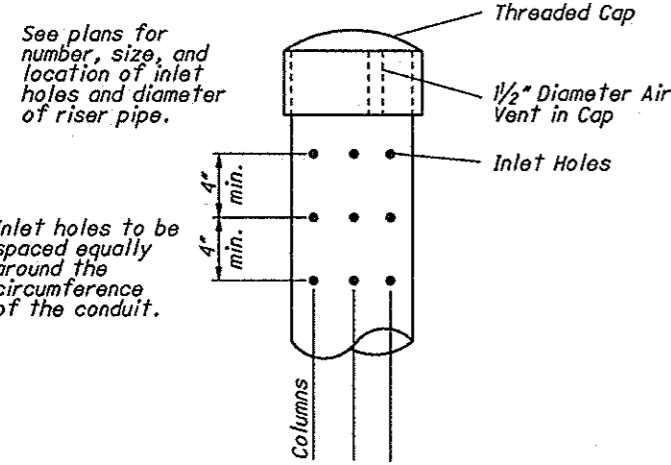

PERFORATED RISER
NOT TO SCALE

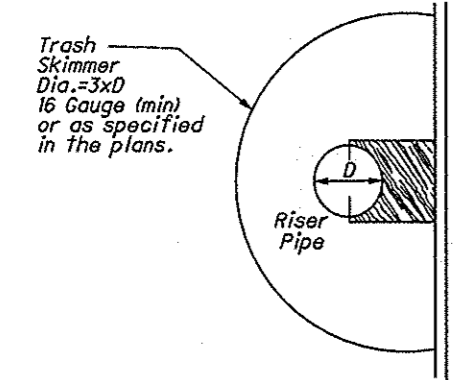

PLAN VIEW (RETENTION SHOWN)
NOT TO SCALE

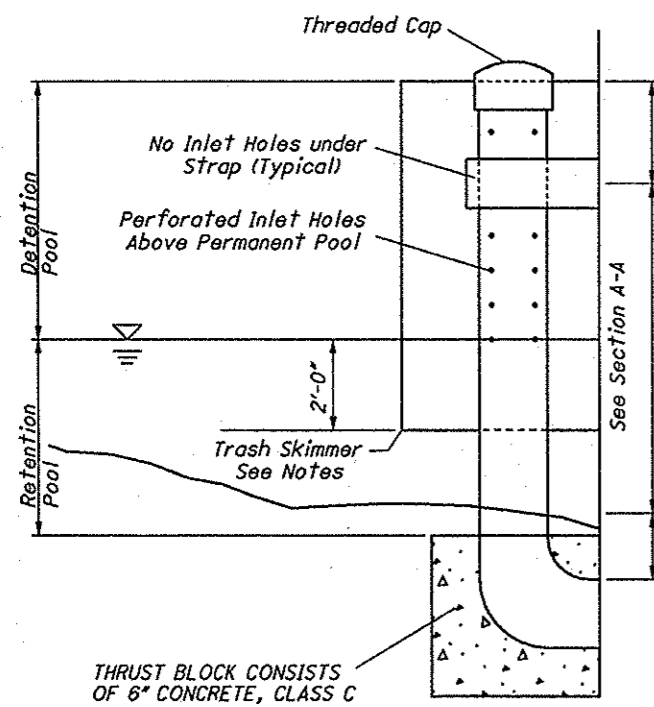

RETENTION RISER PIPE
NOT TO SCALE

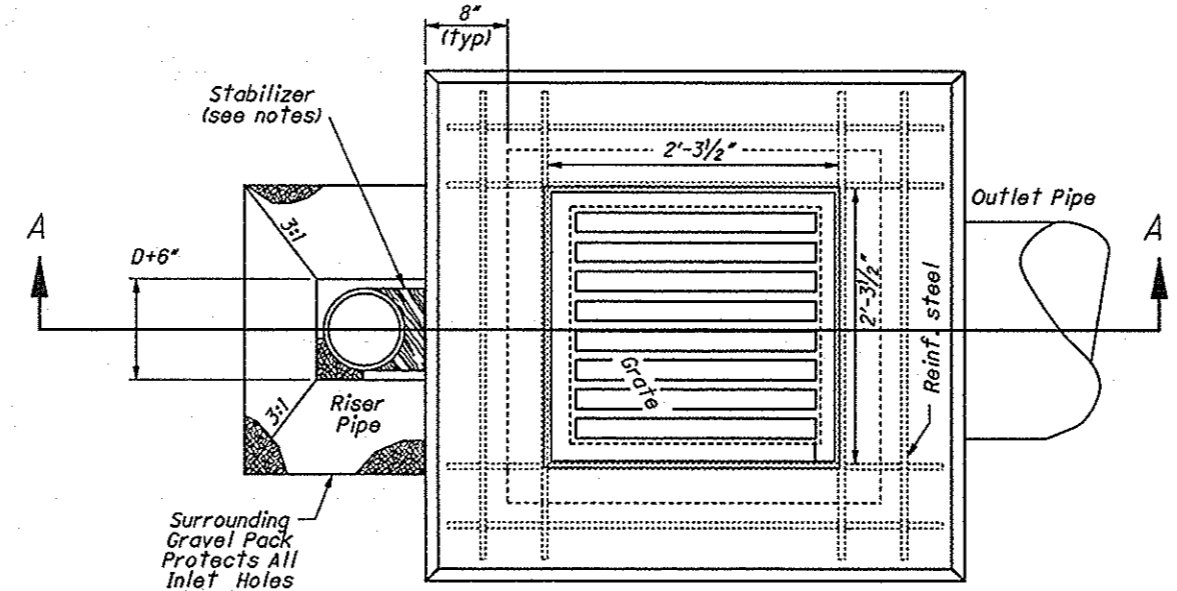

PLAN VIEW (DETENTION SHOWN)
NOT TO SCALE

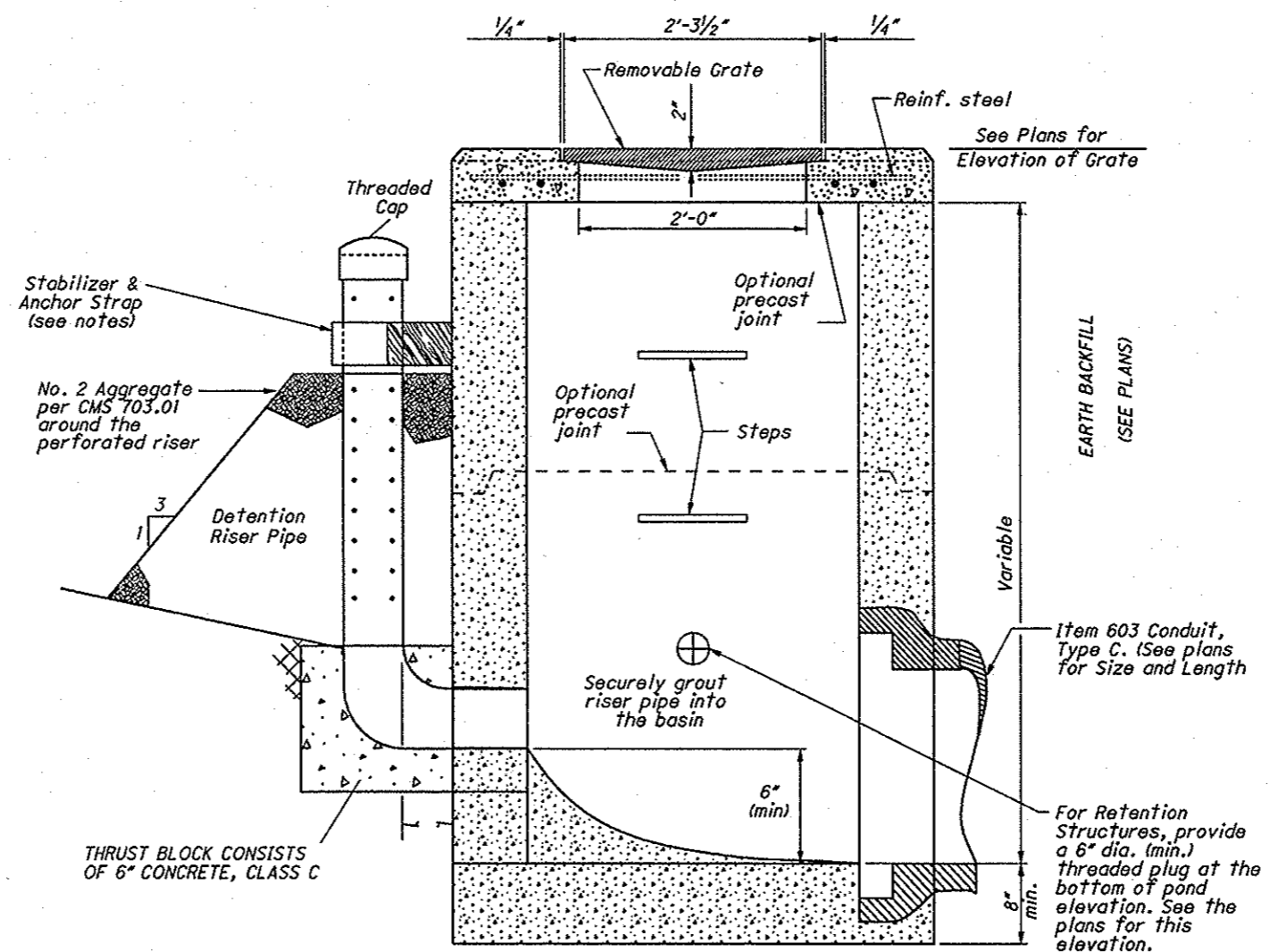

SECTION A-A (DETENTION SHOWN)
NOT TO SCALE

NOTES

LOCATION AND ELEVATION: When given on the plans, the location and the elevation are at the top center of the grate. The orifice holes should be placed at the elevations as shown on the plans.

BASIN MATERIALS: The basin dimensions, materials, and grate are to be per CB-1.2, except as detailed herein. Side inlet windows shall not be used.

All aggregate shown shall meet CMS 203.02 H, NATURAL GRANULAR MATERIALS and specified gradations.

RISER PIPE: Use schedule 40 Polyvinyl Chloride Conduit. Perforations shall be only as detailed in the plans.

TRASH SKIMMER: Use trash skimmer screens to protect the perforated riser. It must extend from the top of the riser to 2' below the permanent pool level and be open at the top and bottom. The radius of the trash skimmer shall be 3 times the diameter of the riser pipe or as shown on the plans. Trash skimmer shall be stainless steel or galvanized steel per CMS 711.02. Maximum perforation size shall be 2 inches. Securely fasten trash skimmer to the basin using hardware galvanized per CMS 711.02.

STABILIZER AND ANCHOR STRAP: Securely fasten the riser pipe to the basin in the vertical position using a stabilizer and anchor strap that consists of a universal clamp or a strap and a block. All metal components shall be galvanized or stainless steel. All other materials shall be rot resistant.

PAYMENT: All materials and labor, including excavation and backfill, shall be paid for at the contract price for Item 604 - Water Quality Basin, Retention (Detention).

MAXIMUM NUMBER OF PERFORATED COLUMNS

RISER DIAMETER (in.)	HOLE DIAMETER, INCHES			
	1/4"	1/2"	3/4"	1"
4	8	8	--	--
6	12	12	9	
8	16	16	12	8
10	20	20	14	10
12	24	24	18	12

12/1/2009 9:22:26 AM shanes M:\CH2009-00.dgn\sheet\11-3-09 ER-5.dgn

CITY OF HEATH
John W. Duff
ZONING SUPERINTENDENT

DATE
11-2009

STANDARD CONSTRUCTION DRAWING
WATER QUALITY BASINS

NUMBER
ER-5

1/1

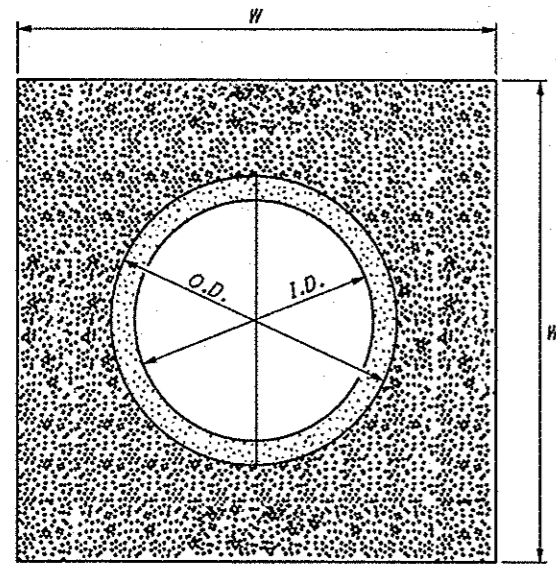

SECTION A-A
(NTS)

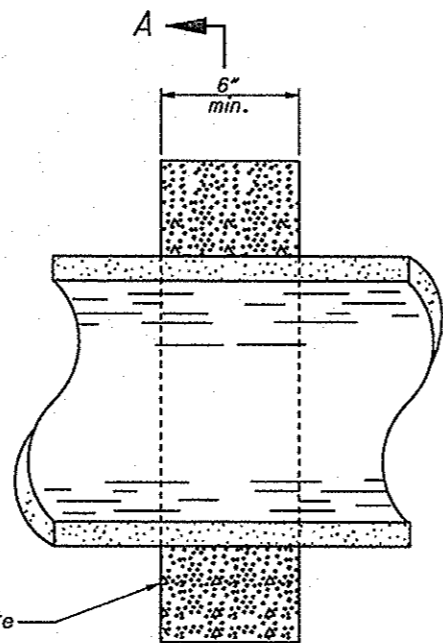

ANTI-SEEP COLLAR
(NTS)

DIAMETER (I.D.) (FT.)	CONCRETE - C.Y.		
	DIMENSION OF COLLAR W X W (FT.)		
	3X3	4X4	5X5
1	0.15	0.28	0.45
2	N/A	0.24	0.40
3	N/A	N/A	0.33

NOTES

ANTI-SEEP COLLARS: An anti-seep collar shall be provided as shown in the plans. Payment for the collar shall be at the contract price for ITEM 602, CONCRETE MASONRY.

WATER QUALITY DITCH CHECK: A water quality ditch check shall be placed as shown in the plans. All embankment used shall conform to CMS 703.16.A. Payment for this work shall be at the contract price for ITEM 203, EMBANKMENT, FOR WATER QUALITY DITCH CHECK.

WATER QUANTITY DITCH CHECK: A water quantity ditch check shall be placed as shown in the plans. All embankment used shall conform to CMS 703.16.A. Payment for this work shall be at the contract price for ITEM 203, EMBANKMENT and ITEM 601, TIED CONCRETE BLOCK MAT FOR WATER QUANTITY SWALE.

OBSERVATION WELL: The observation well shall be constructed to a depth & location as shown in the plans. All materials and labor including excavation and backfill shall be paid for at the contract price for ITEM 604 OBSERVATION WELL.

INFILTRATION TRENCH: The infiltration trench shall be constructed to the dimensions shown on the plan. The top 6 inch covering shall be paid for at the contract price for ITEM 601, INFILTRATION BASIN AGGREGATE.

All other materials and labor, including excavation, geotextile fabric, and backfill shall be paid for at the contract price for ITEM 203 SPECIAL, INFILTRATION TRENCH.

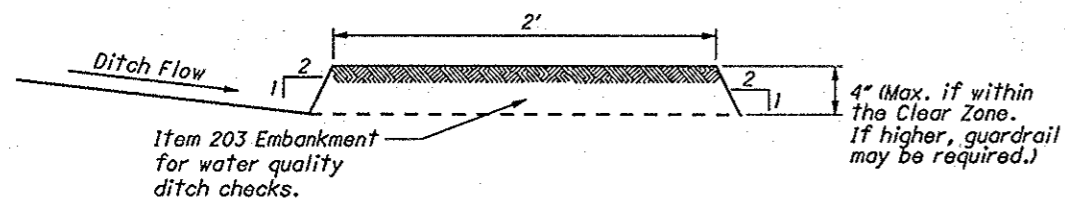

WATER QUALITY DITCH CHECK
(NTS)

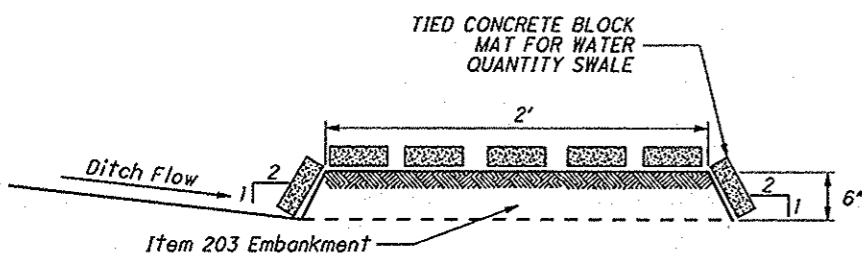

WATER QUANTITY DITCH CHECK
(NTS)

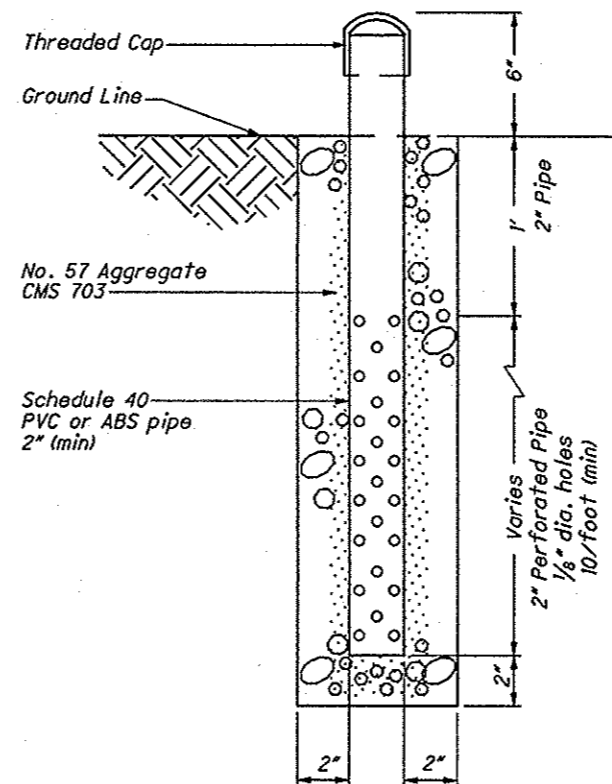

OBSERVATION WELL
NO SCALE

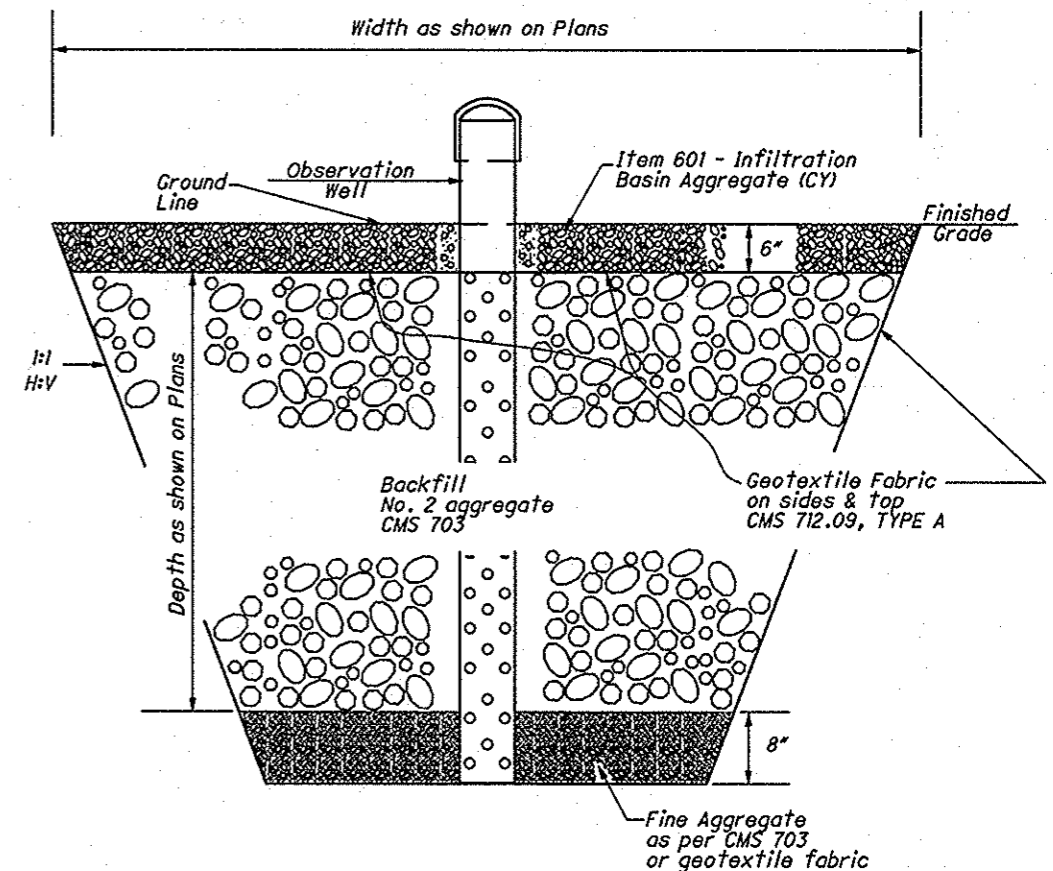

INFILTRATION TRENCH
NO SCALE

12/1/2009 9:22:30 AM M:\CH2009-00\dgn\sheets\11-3-09 ER-6.dgn

STANDARD CONSTRUCTION DRAWING
WATER QUALITY - MISCELLANEOUS

CITY OF HEATH
ZONING SUPERINTENDENT
John W. [Signature]

DATE
11-2009

NUMBER
ER-6

1/1

NOTES

EXFILTRATION TRENCH (EXT): The exfiltration box structure shall be located as shown on the plans.

The exfiltration box structure may be precast, cast in the field or a combination of precast and cast in the field. The minimum length of a precast exfiltration box structure is 4'. More than 1 precast section may be provided to meet the required length shown in the plans.

Exfiltration trench base concrete shall conform to CMS 511.

If the exfiltration box structure is precast, furnish reinforcing steel conforming to CMS 509.02 and CMS 709.00 for the precast structure in a sufficient amount to permit shipping and placement without damage. Locate all lifting devices on the exterior side walls of the precast structure.

Maintain the cross slope of the pavement as shown on the Standard Construction Drawing or as shown on the plans. Additional variations in dimensions from the Standard Construction Drawing for precast exfiltration box structures may occur. Variances for precast structure dimensions must be approved by the Office of Structural Engineering, Hydraulics Section.

Furnish 6" epoxy coated #4 reinforcing bars, conforming to CMS 509.02 and 709.00, to be used as dowels to connect proposed barrier or field cast curb to the top of the precast exfiltration box structure and to connect EXT gutter and exfiltration box structure. Space dowels for curb every 12" on center for the length of the exfiltration box structure. Space dowels for EXT gutter 12" from the ends of the EXT base and every 18" on center for the length of the exfiltration box structure. When dowels are required, drill in place or precast the dowel opening. If dowel openings are drilled, fill with epoxy when placing the dowel. Inserts for dowels shall be galvanized.

Concrete for 12" exfiltration trench gutter for Exfiltration Trench Type A shall conform to CMS 609. Cost for the concrete shall be included in the price of Item 835 - Exfiltration Trench, Type A. Cost for the 4" perforated conduit (Item 707.31), filter media, and exfiltration trench box structure shall be included in the price of Item 835 - Exfiltration Trench, Type A. Cost for the curb for EXT, Types A and C shall be included in the price of Item 835 - Exfiltration Trench, Type A. Cost for Barrier for EXT, Type B shall be included with the Barrier.

All materials and labor, including excavation and backfill shall be paid for at the contract price for ITEM 835 - EXFILTRATION TRENCH, TYPE ____.

- 1 Exfiltration Trench Filter Media (See SS835) - Maintain free from debris and sediment laden runoff throughout construction of the project.
- 2 22" for 4" Curb and Gutter and 24" for 6" Curb and Gutter.
- 3 Furnish preformed expansion joint material according to 705.03 when abutting concrete.
- 4 Optional Construction Joint w/ dowels.
- 5 Location for Station and Offset. Elevation according to Typical Section.
- 6 If curb portion is to be cast in field, furnish dowels for the curb as shown for Type A and C. For 4" and 6" curb height, extend the dowels 2" and 3", respectively, above the exfiltration trench base.
- 7 Match the cross slope of the top of the EXT walls, the top of the filter media, and the EXT gutter (if applicable) with the proposed cross slope of the adjacent pavement or gutter cross slope.
- 8 Determine the front wall dimension of the EXT by using the dimensions at the outside edge of the back wall and the cross slope from 7.

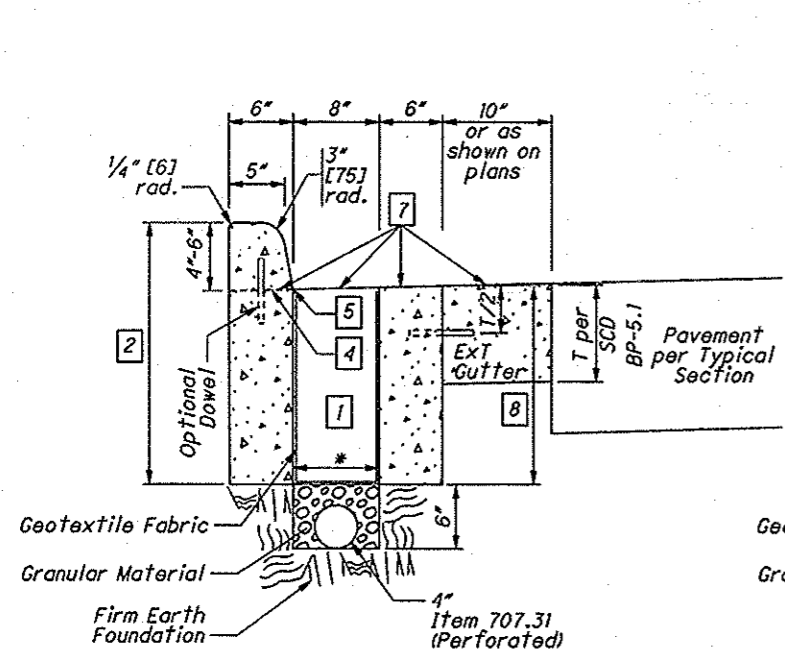
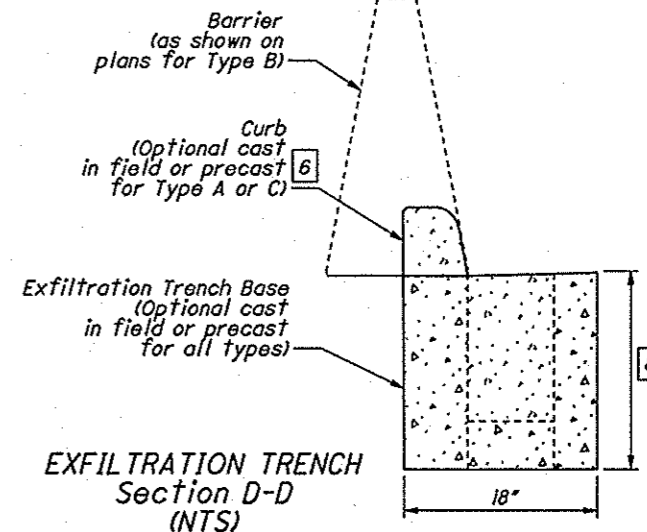

EXFILTRATION TRENCH TYPE A - Section A-A Curb and Gutter Application (NTS)

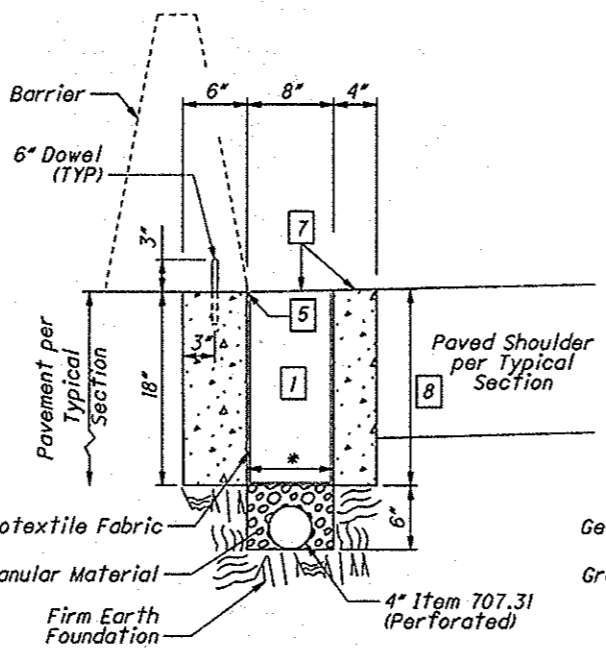

EXFILTRATION TRENCH TYPE B - Section B-B Barrier Application (NTS)

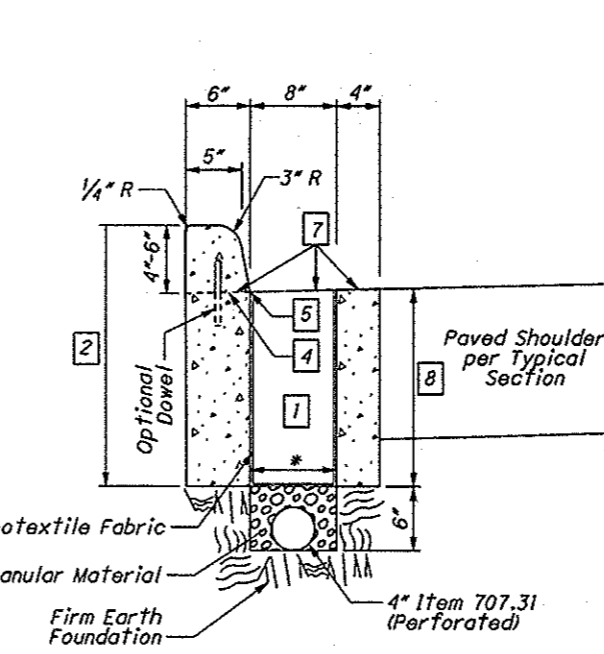

EXFILTRATION TRENCH TYPE C - Section C-C Various Curb Application (NTS)

* Bottom dimension may be reduced by up to 1/2" to assist in form removal during construction

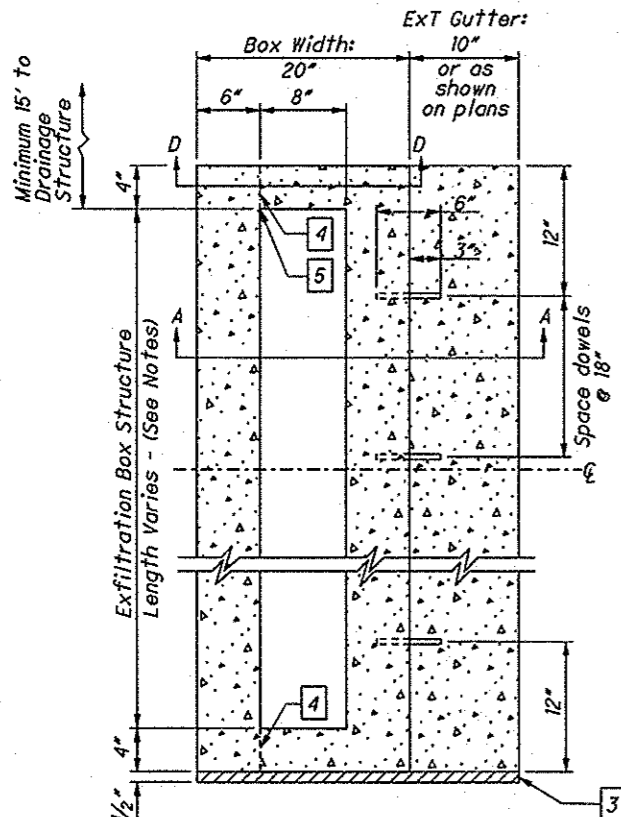

EXFILTRATION TRENCH TYPE A Plan View (NTS)

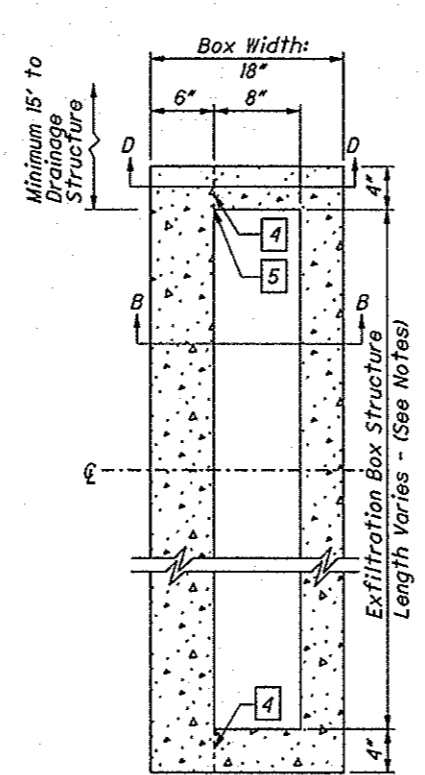

EXFILTRATION TRENCH TYPE B Plan View (NTS)

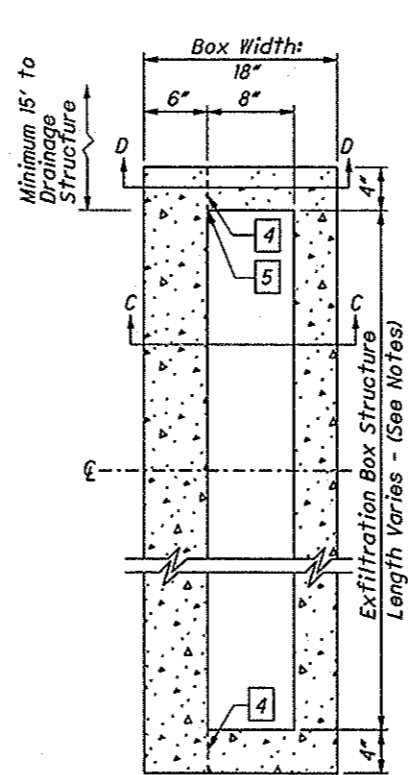

EXFILTRATION TRENCH TYPE C Plan View (NTS)

3 Preformed Joint Material, Item 705.03 with Joint Sealer

12/1/2009 9:22:34 AM M:\CH2009-00.dgn\sheet\11-3-09 ER-7.dgn

CITY OF HEATH ZONING SUPERINTENDENT DATE 11-2009 STANDARD CONSTRUCTION DRAWING WATER QUALITY - EXFILTRATION TRENCH NUMBER ER-7

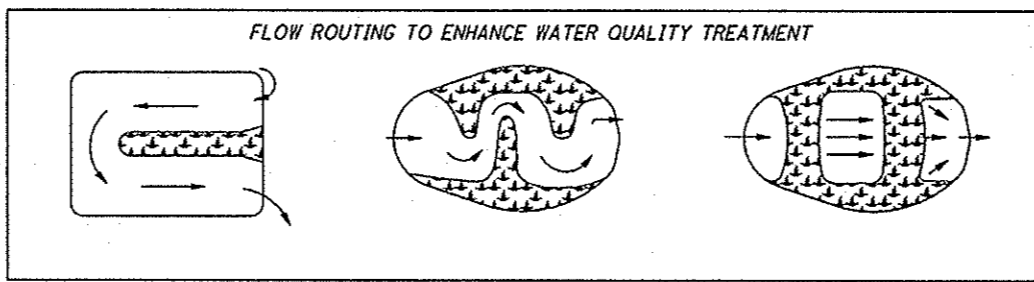
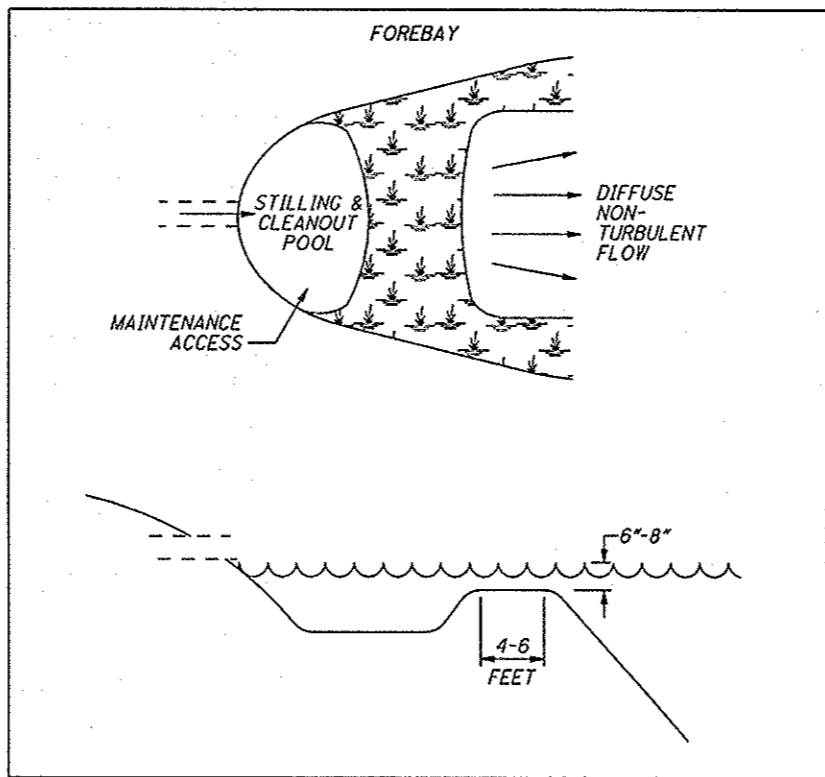

CITY OF HEATH
[Signature]
ZONING SUPERINTENDENT

DATE
11-2009

STANDARD CONSTRUCTION DRAWING
PERMANENT SEDIMENT CONTROL - FLOW ROUTING

NUMBER
ER-8

1 / 1